



US00D399268S

United States Patent [19]
Liu

[11] **Patent Number: Des. 399,268**

[45] **Date of Patent: **Oct. 6, 1998**

[54] **VIDEO GAME**

5,217,295 6/1993 Tortola et al. 362/109
5,232,223 8/1993 Osterhout et al. 273/148 B

[76] Inventor: **Da-Ming Liu**, 5F., No. 13, Pao Kao Road, Hsin Tien, Taipei Hsien, Taiwan

OTHER PUBLICATIONS

HongKong Enterprise, p. 133, Oct. 1994.
HongKong Enterprise, p. 461, Oct. 1994.

[**] Term: **14 Years**

Primary Examiner—Prabhakar G. Deshmukh
Attorney, Agent, or Firm—Jacobson, Price, Holman & Stern, PLLC

[21] Appl. No.: **79,891**

[22] Filed: **Nov. 25, 1997**

[51] **LOC (6) Cl.** **21-01**

[52] **U.S. Cl.** **D21/13**

[58] **Field of Search** D21/1, 13, 48;
273/148 B; 463/1, 30-35, 46, 47, 48

[57] **CLAIM**

The ornamental design for video game, as shown and described.

DESCRIPTION

FIG. 1 is a perspective view of video game showing my new design;
FIG. 2 is a front elevational view thereof;
FIG. 3 is a rear elevational view thereof;
FIG. 4 is a left side elevational view thereof;
FIG. 5 is a right side elevational view thereof; and,
FIG. 6 is a top plan view thereof; the bottom plan view being a mirror image thereof.

[56] **References Cited**

U.S. PATENT DOCUMENTS

D. 262,720	1/1982	Dweck	D21/13
D. 309,161	7/1990	Leung	D21/13
D. 347,246	5/1994	Wen	D21/13
D. 368,282	3/1996	Lin	D21/13
D. 380,501	7/1997	Osterhout et al.	D21/13
D. 382,914	8/1997	Ho et al.	D21/13
3,924,350	12/1975	Hsu	273/457 X
5,184,830	2/1993	Okada et al.	463/29

1 Claim, 4 Drawing Sheets

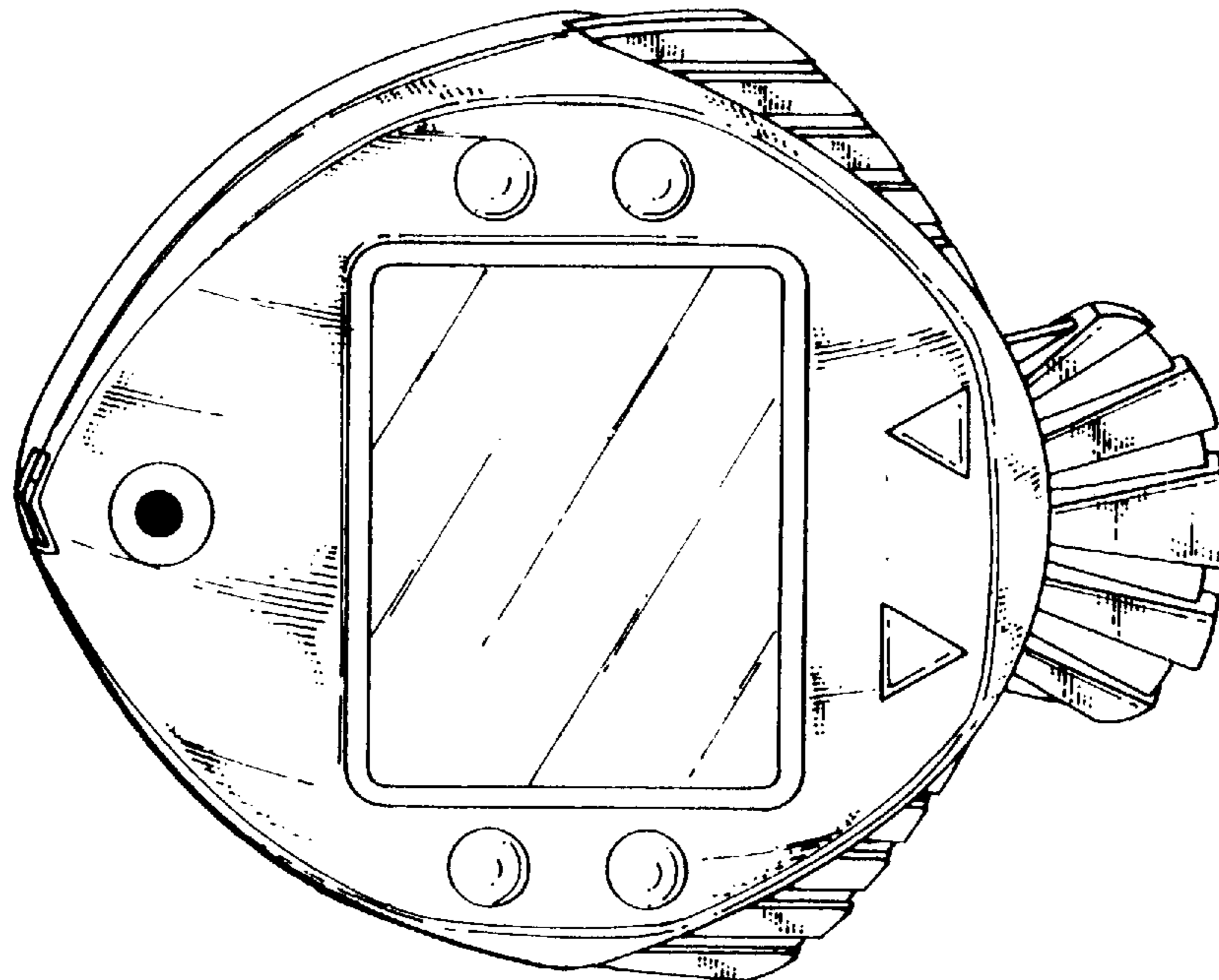

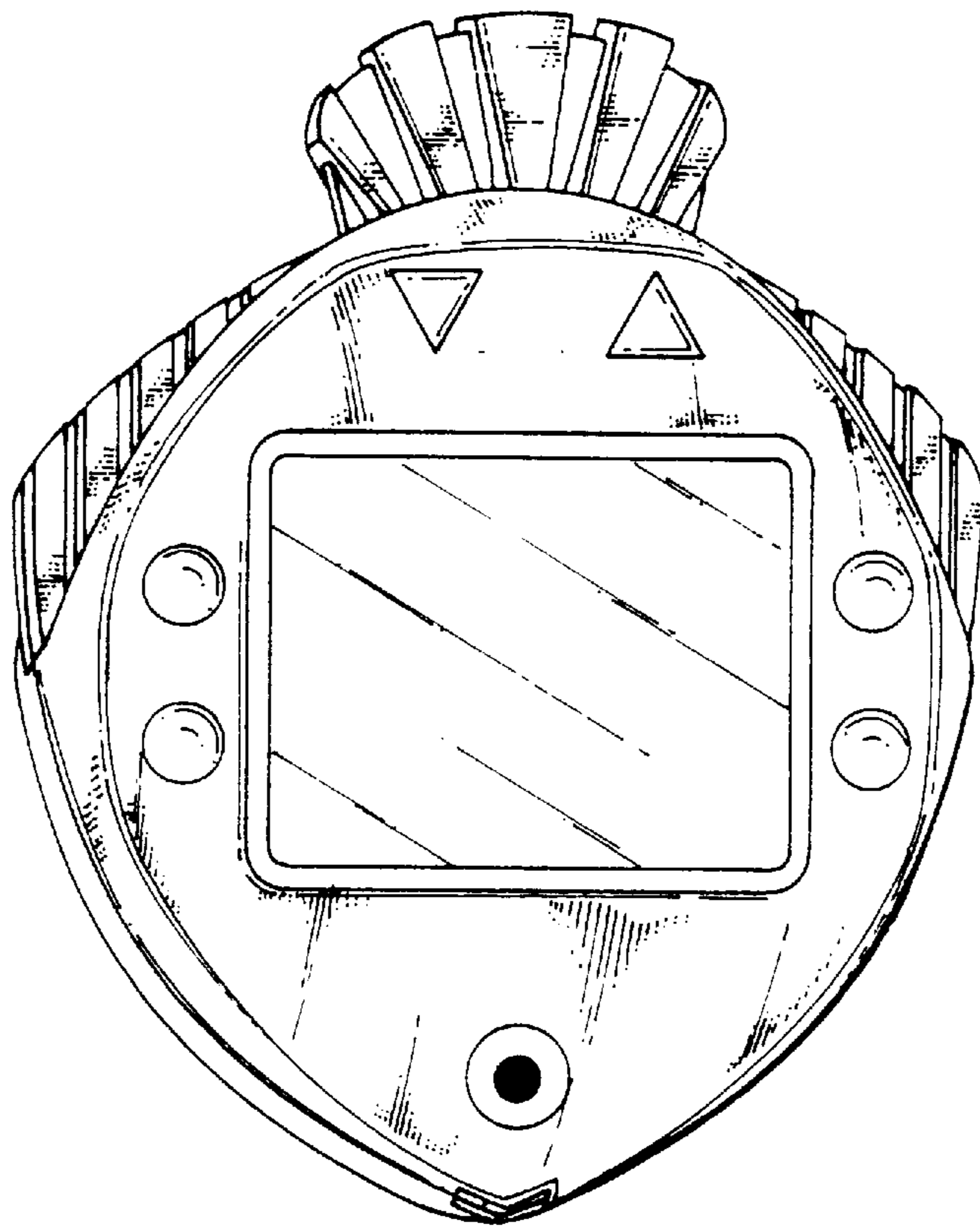

FIG 1

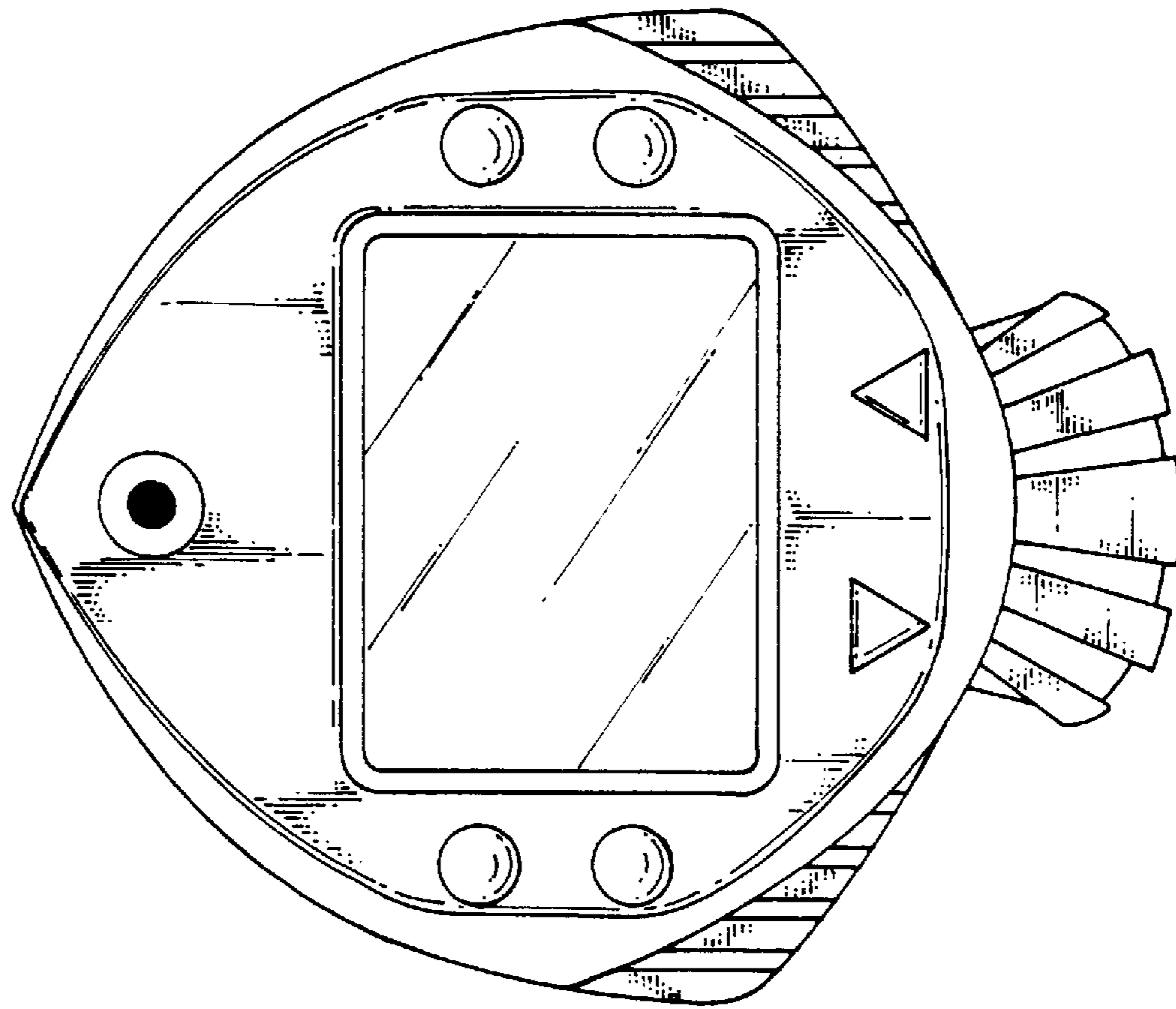

FIG 2

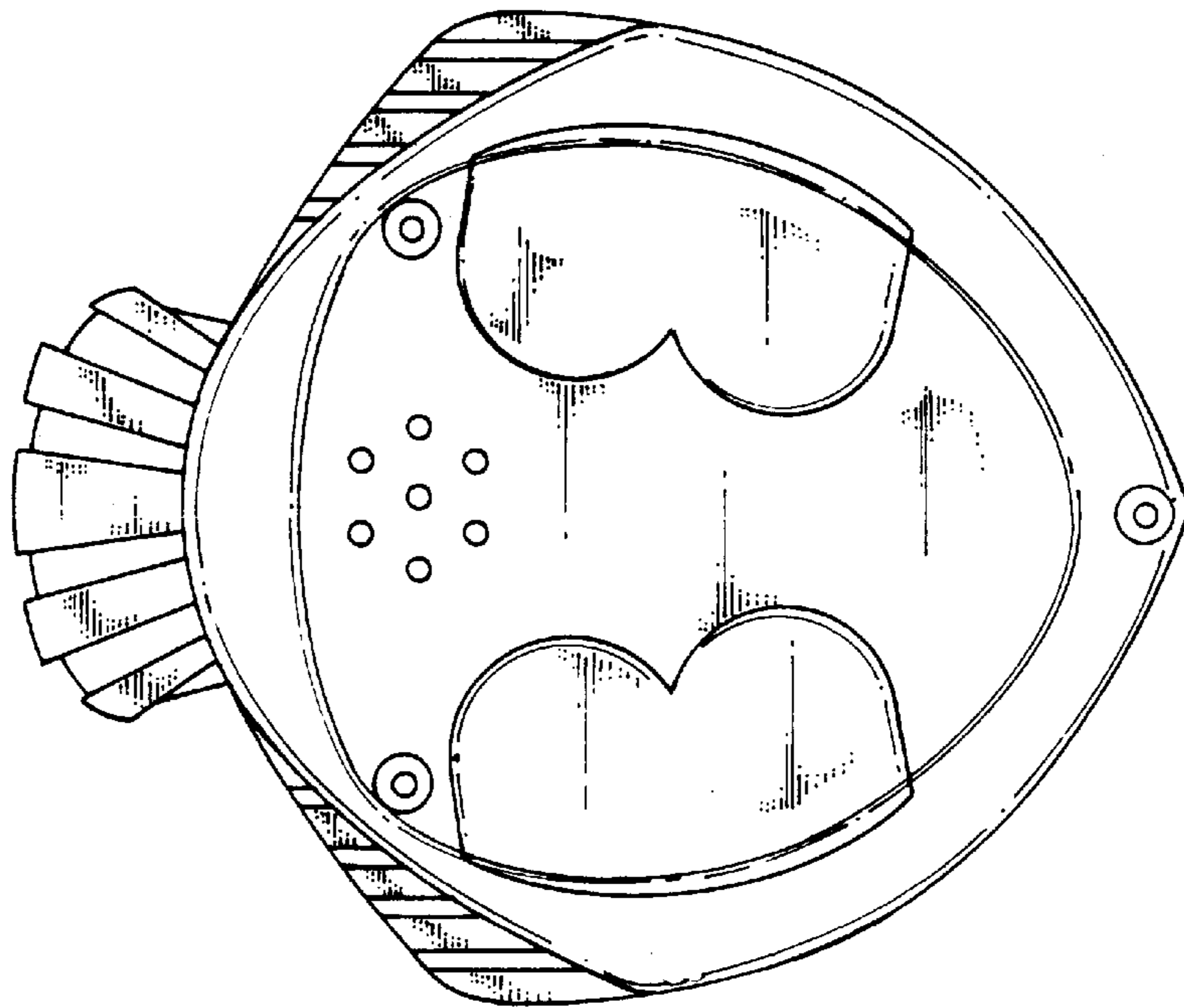

FIG 3

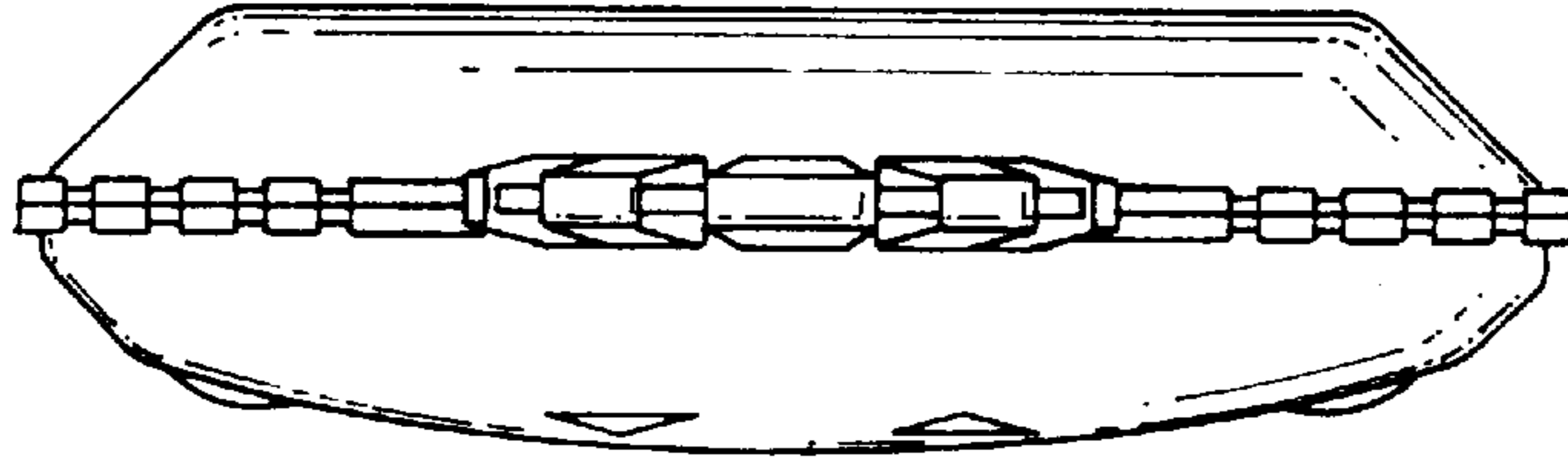

FIG 5

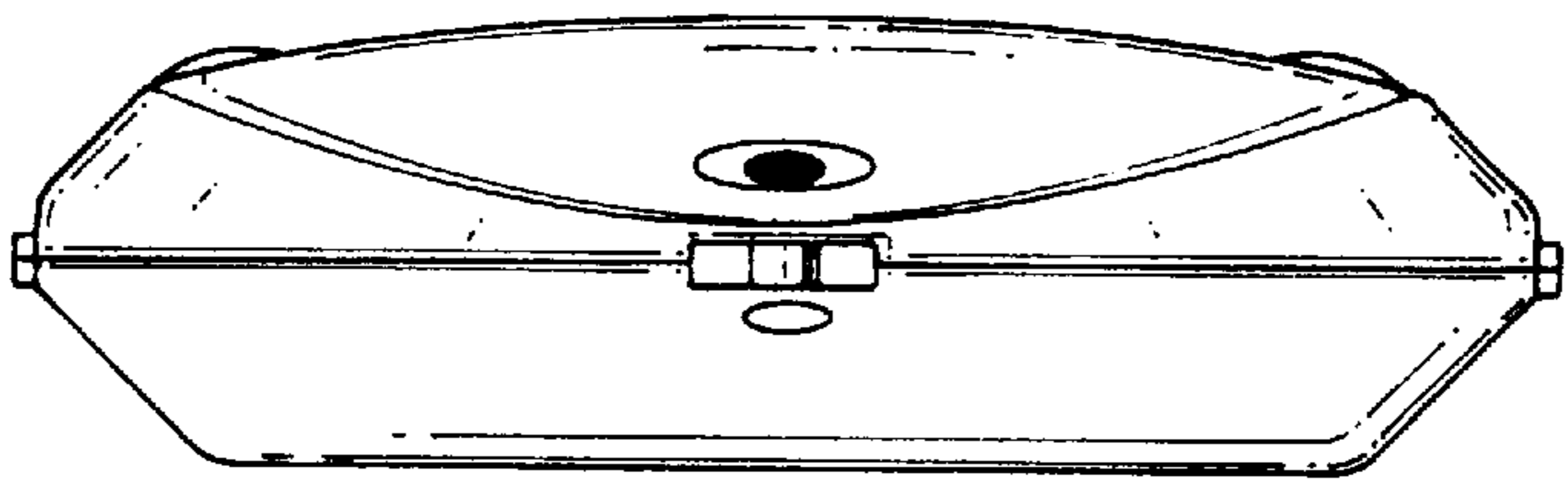

FIG 4

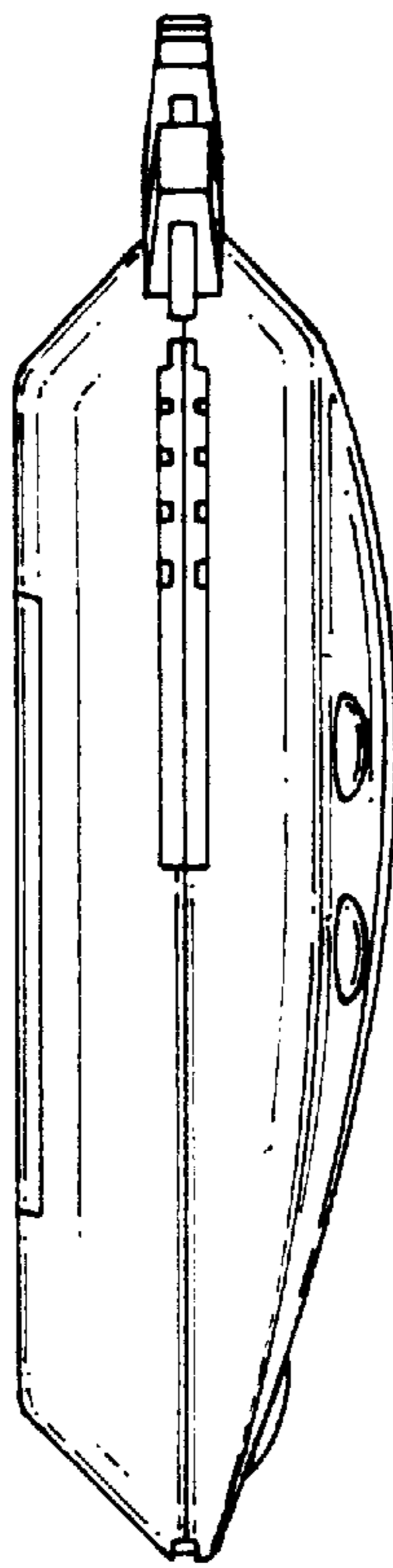

FIG 6