



US00D399182S

United States Patent [19]

Lapointe et al.

[11] Patent Number: Des. 399,182

[45] Date of Patent: **Oct. 6, 1998

[54] PERSONAL WATERCRAFT

[75] Inventors: **Denys Lapointe**, Quebec, Canada;
Shannon Cassell, Palm Bay; **Tom Bucaccio**, Grant, both of Fla.

[73] Assignee: **Bombardier, Inc.**, Quebec, Canada

[**] Term: **14 Years**

[21] Appl. No.: **65,469**

[22] Filed: **Jan. 23, 1997**

[51] LOC (6) Cl. **12-06**

[52] U.S. Cl. **D12/307**

[58] Field of Search D12/300-318;
114/270, 271, 56

[56] **References Cited**

U.S. PATENT DOCUMENTS

D. 340,221	10/1993	Krieger et al.	D12/307
D. 342,931	1/1994	Mardikian	D12/307
D. 359,265	6/1995	Leiva	D12/307
5,570,654	11/1996	Rood	114/363

OTHER PUBLICATIONS

Sea•Doo Brochure, Bombardier, Inc., Sep. 1995.

Primary Examiner—Kay H. Chin

Attorney, Agent, or Firm—St. Onge Steward Johnston & Reens LLC

[57] **CLAIM**

The ornamental design for a personal watercraft, as shown and described.

DESCRIPTION

FIG. 1 is a perspective view of the personal watercraft;

FIG. 2 is a top plan view thereof;
 FIG. 3 is a left side elevational view thereof;
 FIG. 4 is a right side elevational view thereof;
 FIG. 5 is a front elevational view thereof;
 FIG. 6 is a rear elevational view thereof;
 FIG. 7 is a bottom plan view thereof;
 FIG. 8 is a perspective view of a second embodiment of the personal watercraft;
 FIG. 9 is a top plan view thereof;
 FIG. 10 is a left side elevational view thereof;
 FIG. 11 is a right side elevational view thereof;
 FIG. 12 is a front elevational view thereof;
 FIG. 13 is a rear elevational view thereof;
 FIG. 14 is a perspective view of a third embodiment of the personal watercraft;
 FIG. 15 is a top plan view thereof;
 FIG. 16 is a left side elevational view thereof;
 FIG. 17 is a right side elevational view thereof;
 FIG. 18 is a front elevational view thereof;
 FIG. 19 is a rear elevational view thereof;
 FIG. 20 is a perspective view of a fourth embodiment of the personal watercraft;
 FIG. 21 is a top plan view thereof;
 FIG. 22 is a left side elevational view thereof;
 FIG. 23 is a right side elevational view thereof;
 FIG. 24 is a bottom plan view thereof;
 FIG. 25 is a front elevational view thereof; and,
 FIG. 26 is a rear elevational view thereof.

The broken line structures shown in FIGS. 8 through 26 are for illustrative purposes only and form no part of the second, third and fourth embodiments.

1 Claim, 12 Drawing Sheets

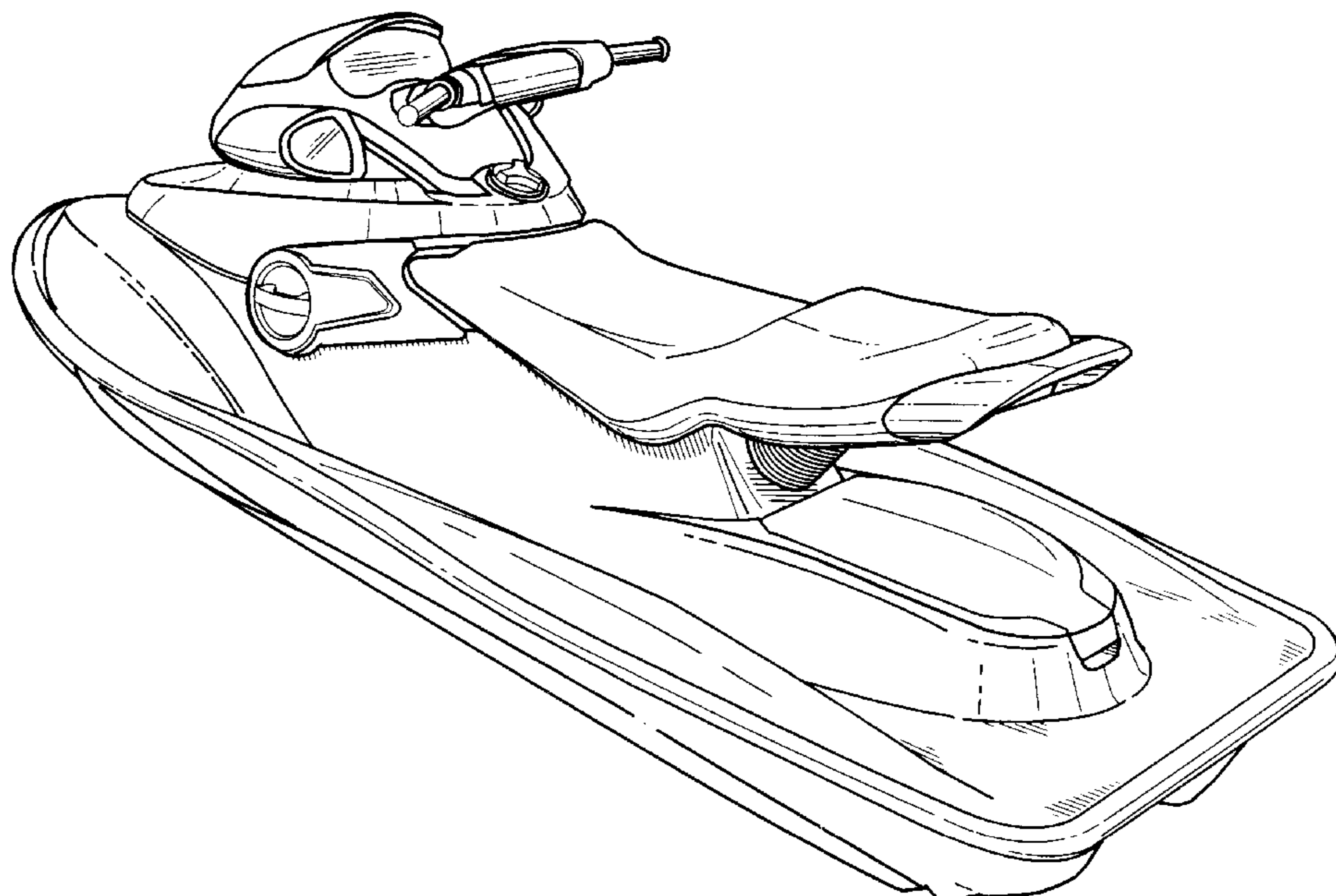

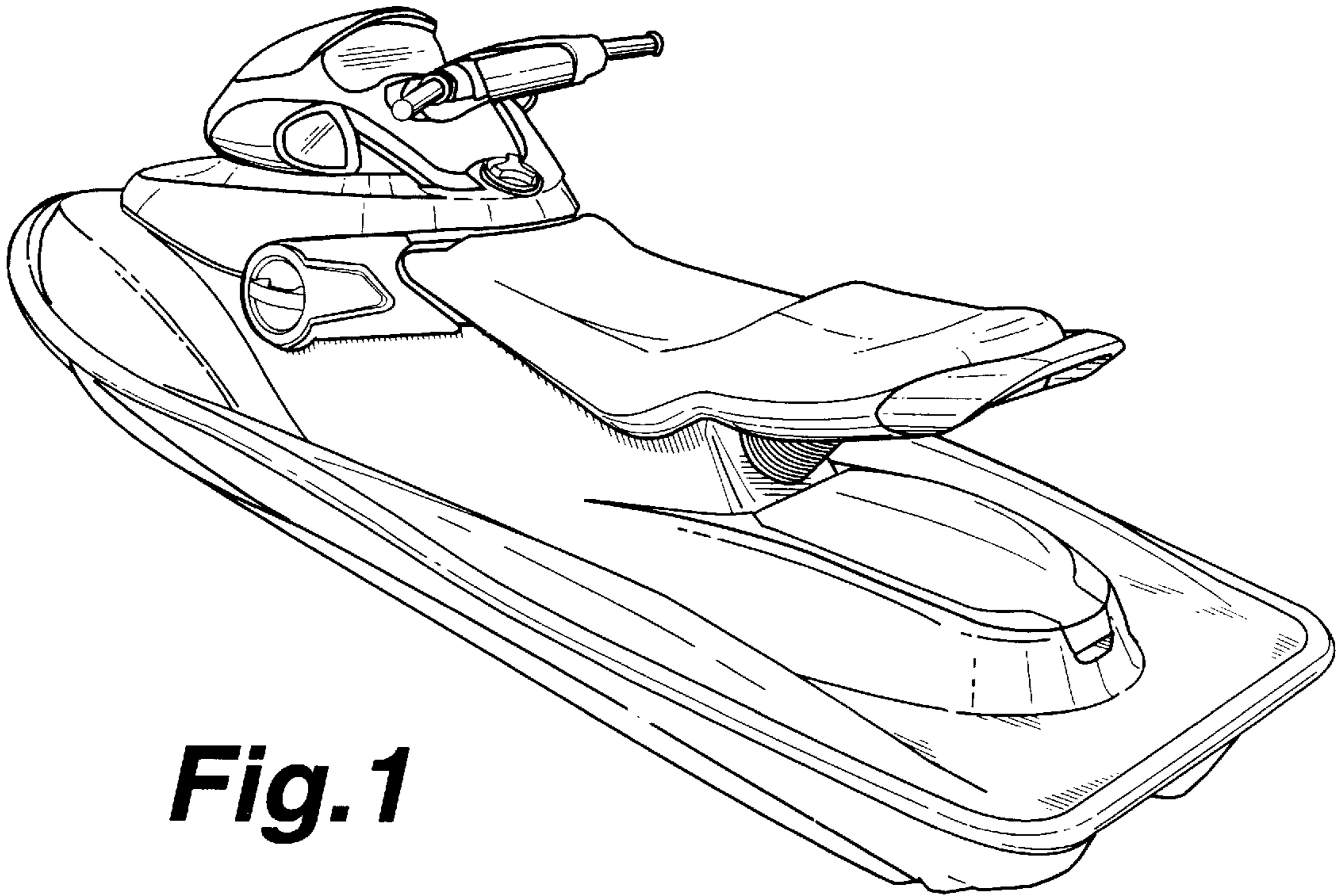

Fig. 1

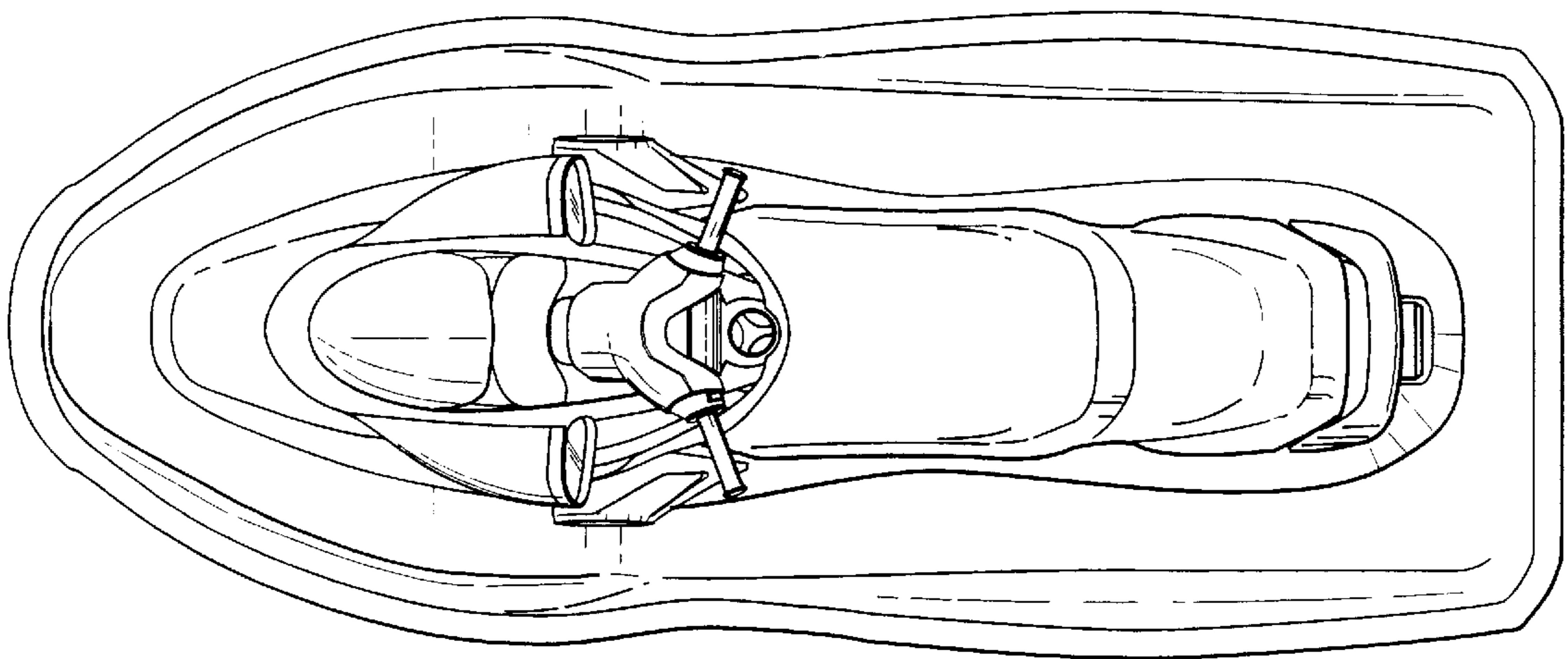

Fig. 2

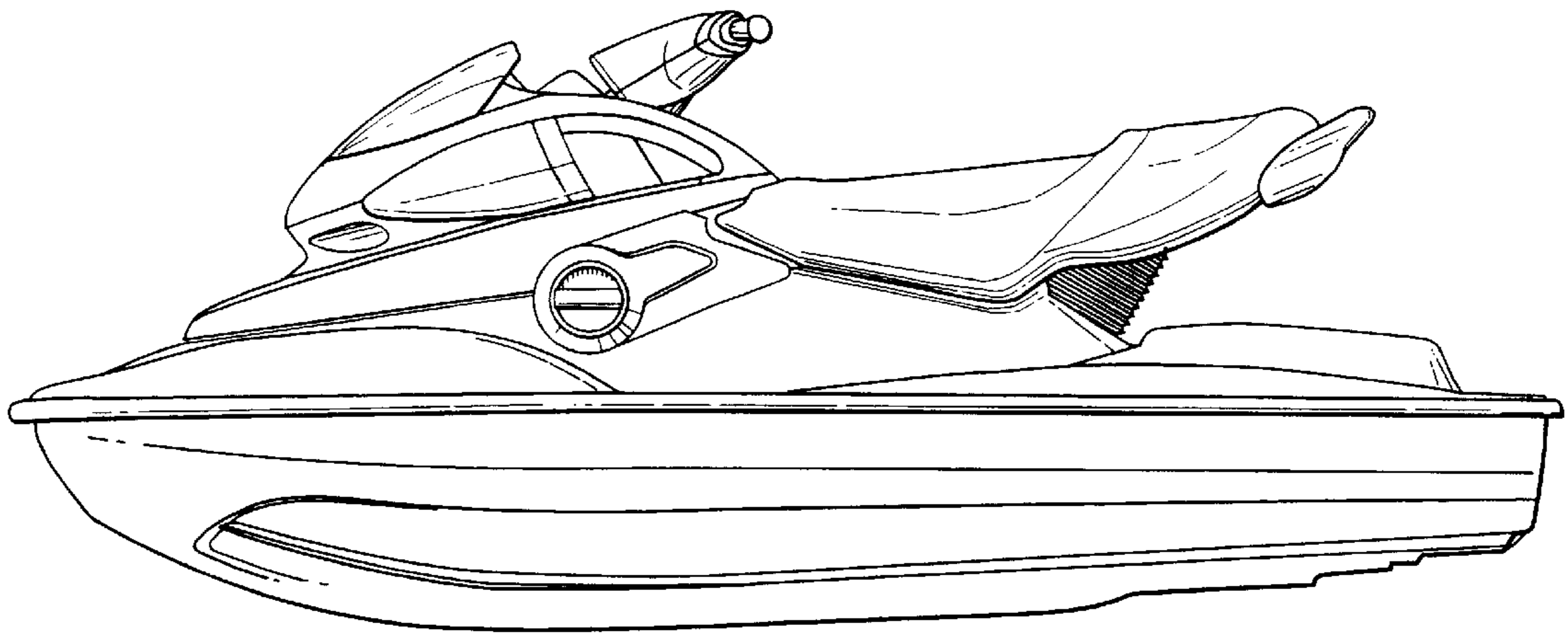

Fig.3

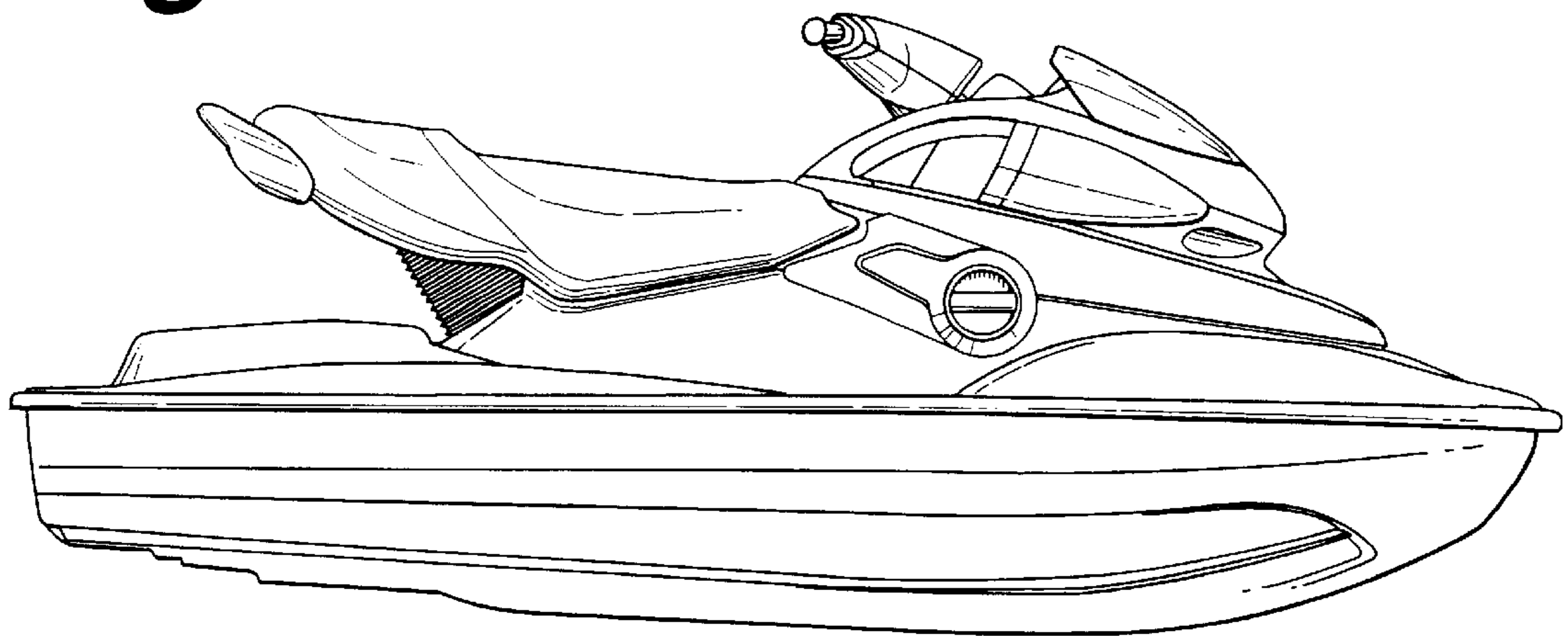

Fig.4

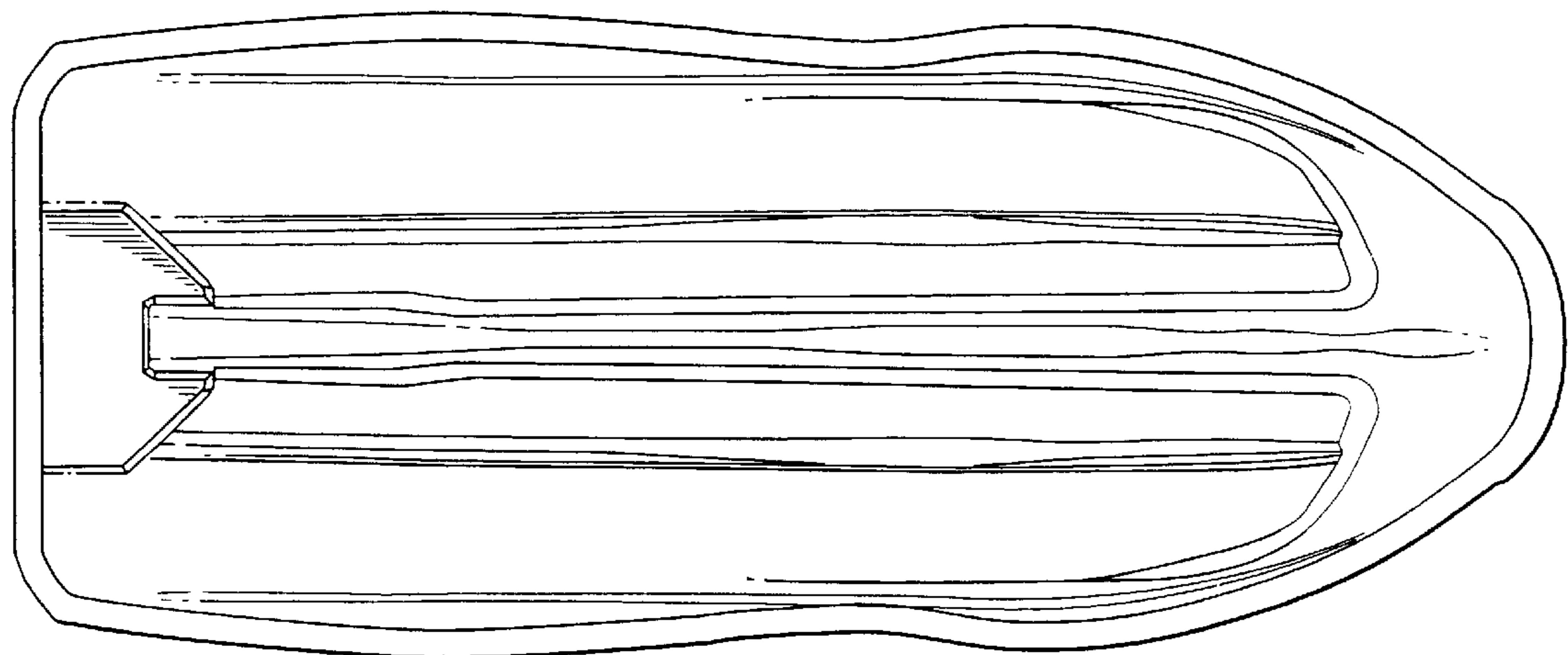

Fig.7

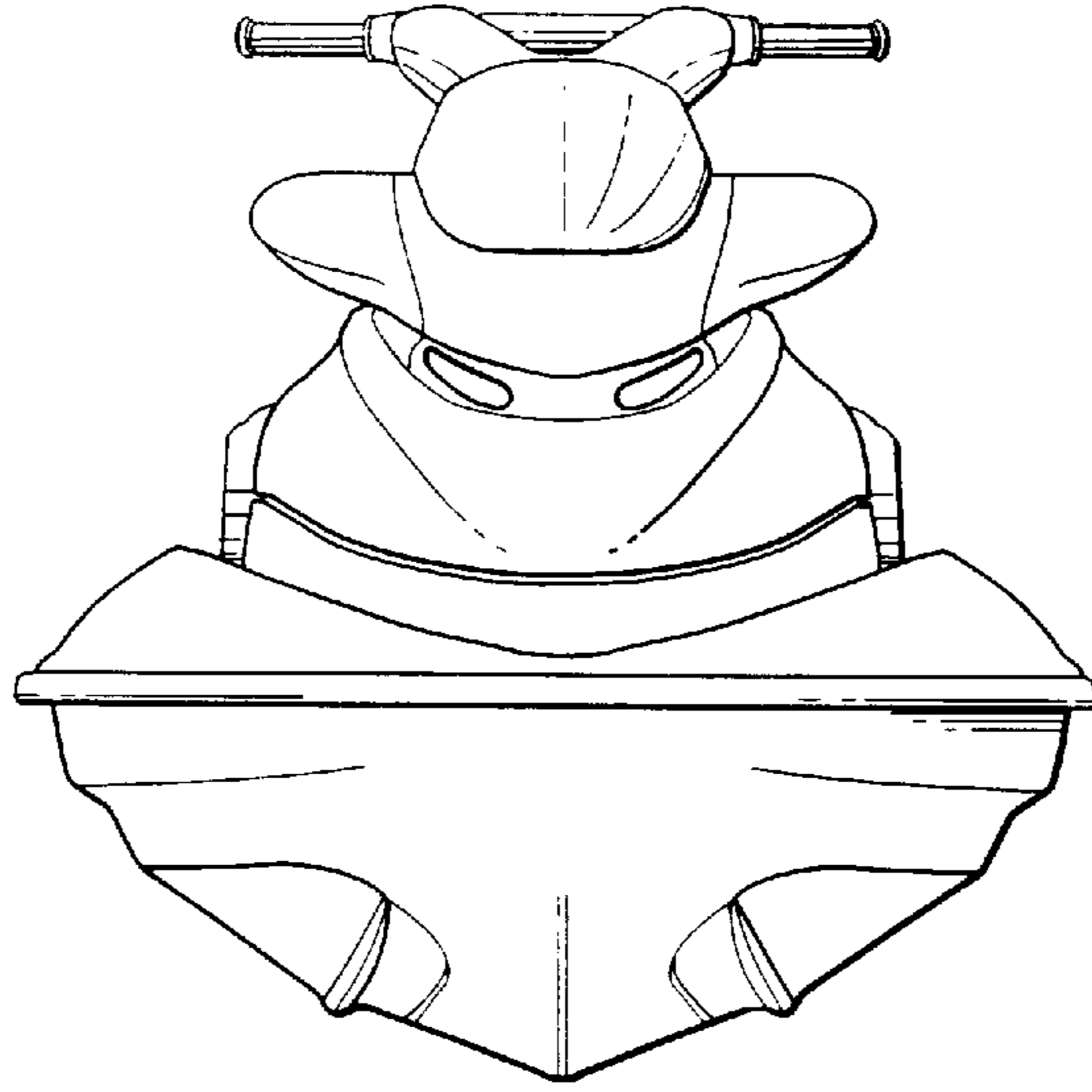

Fig.5

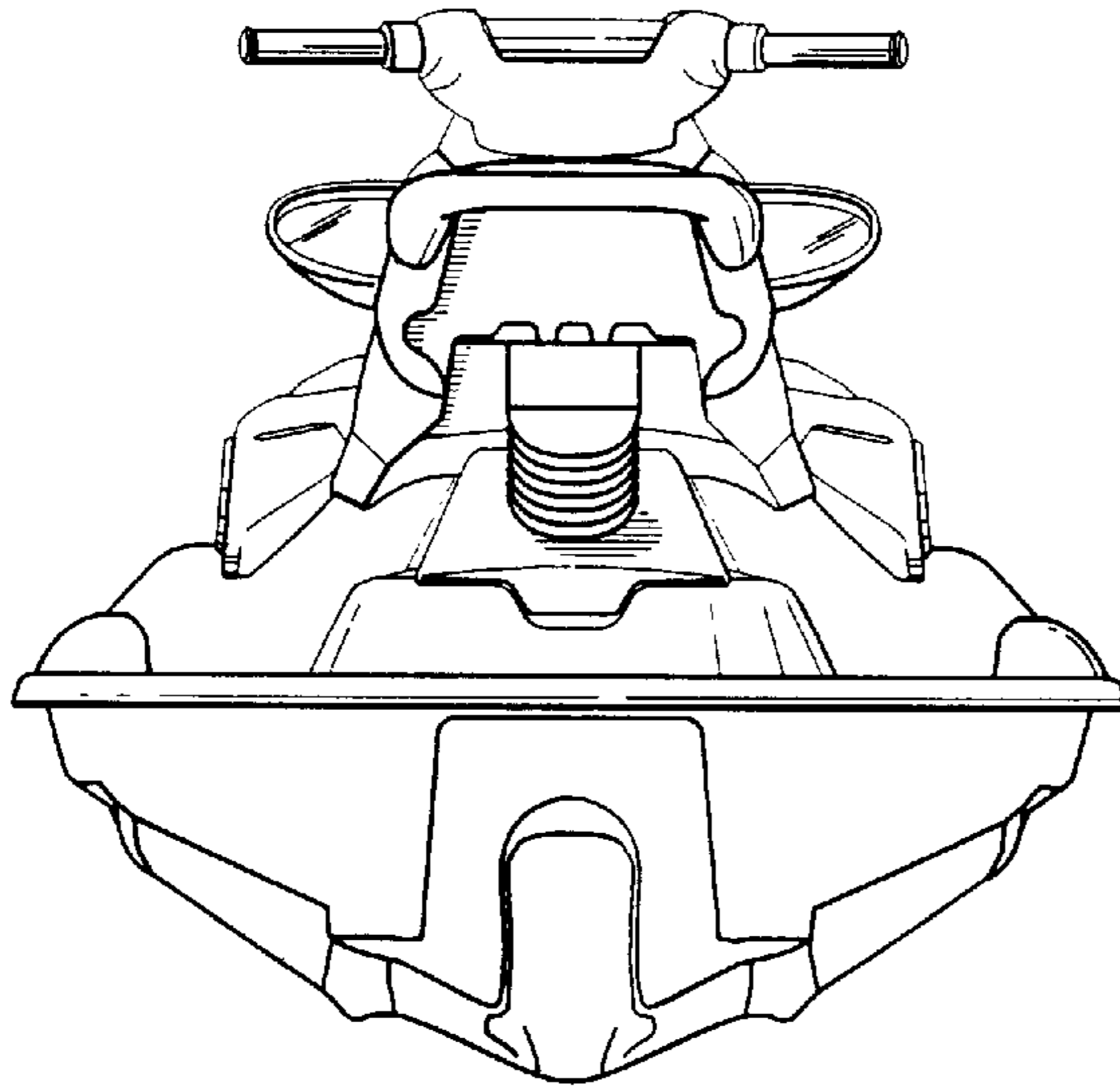

Fig.6

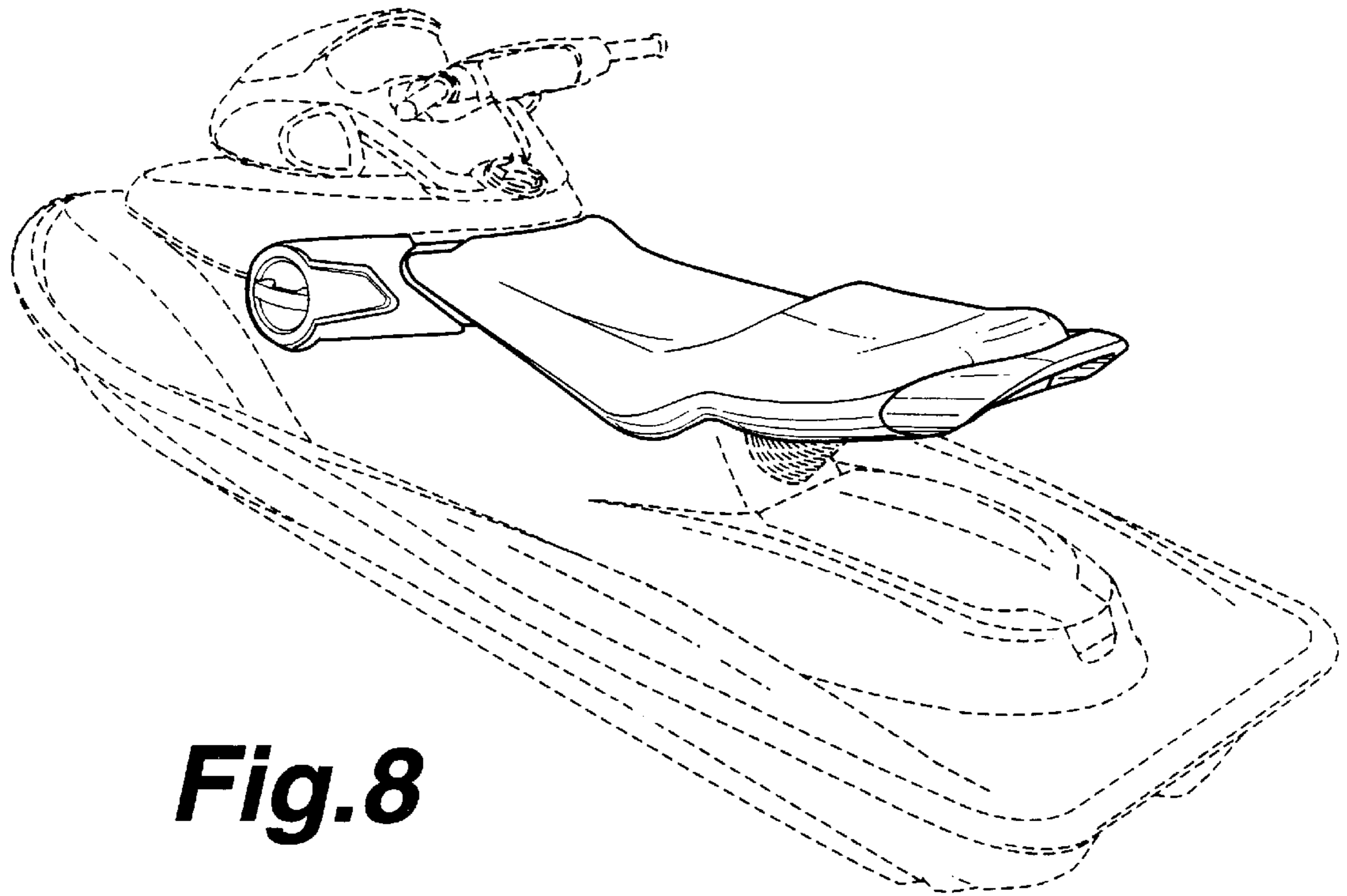

Fig. 8

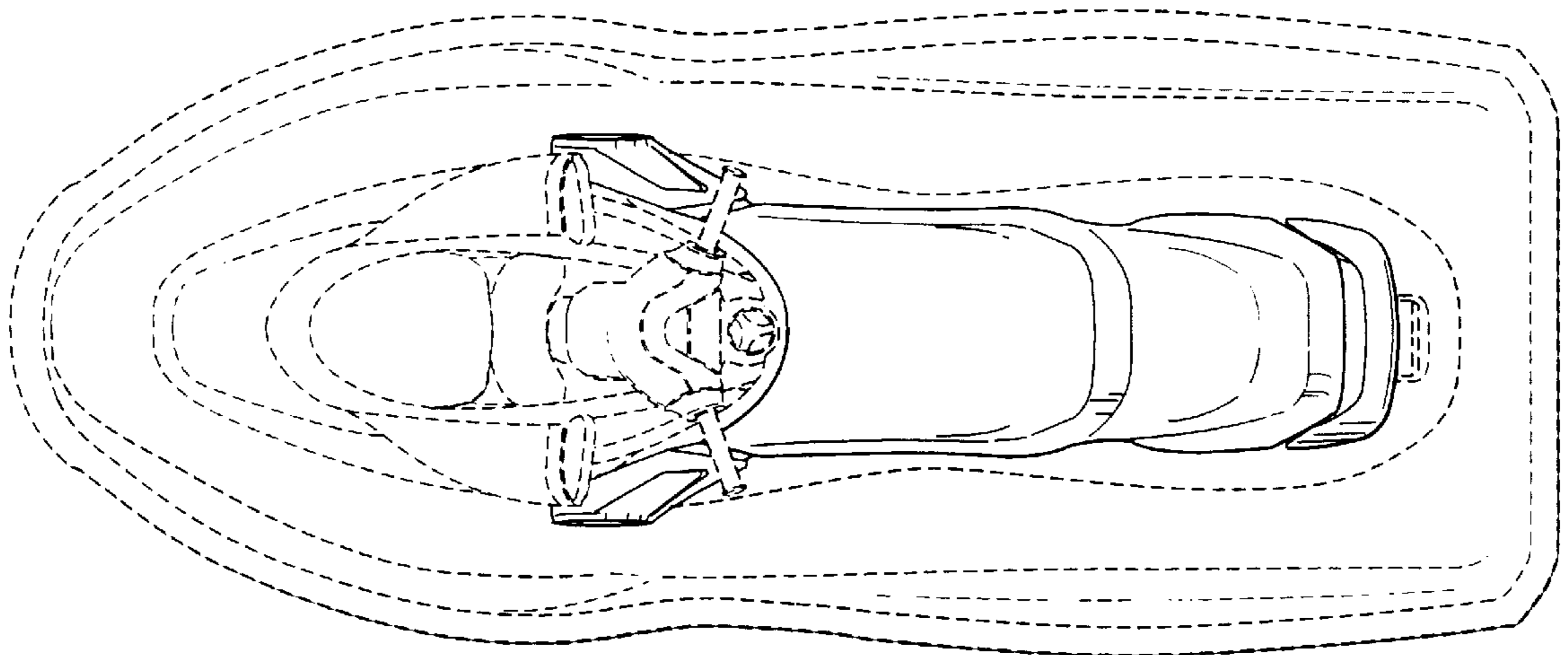

Fig. 9

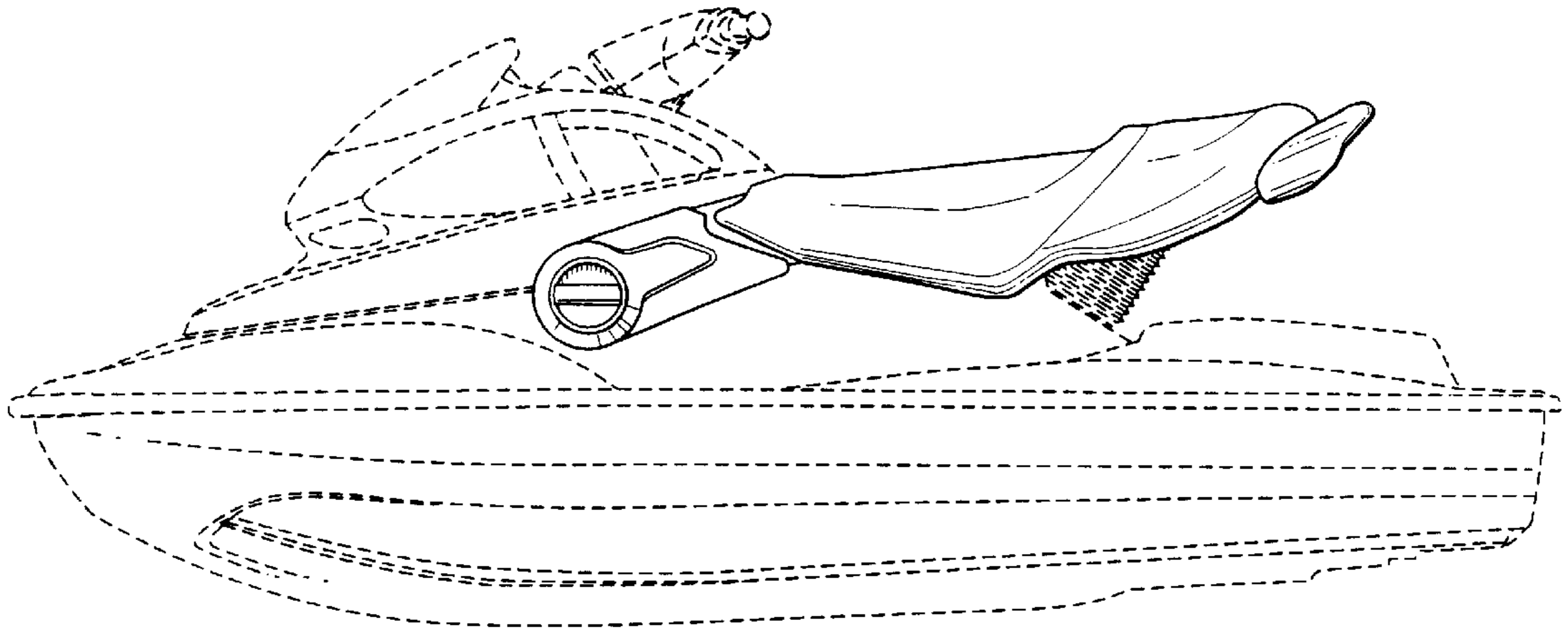

Fig. 10

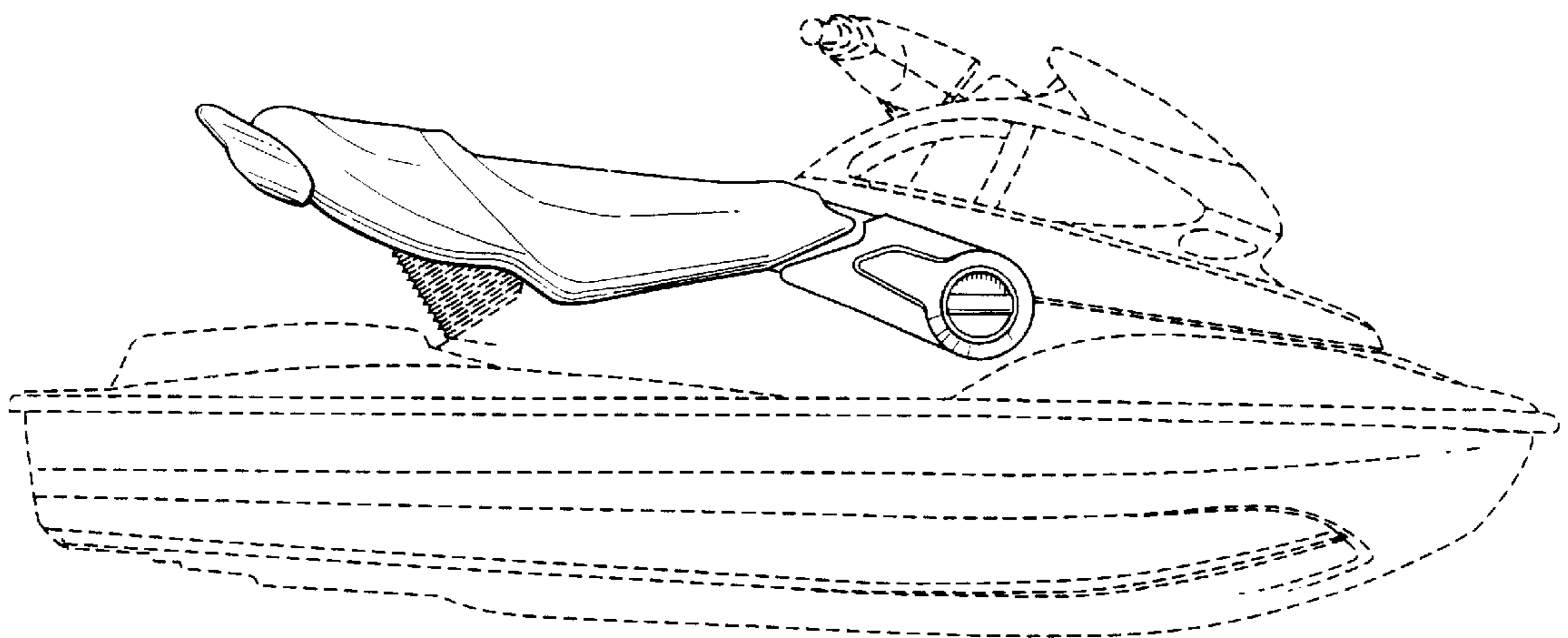

Fig. 11

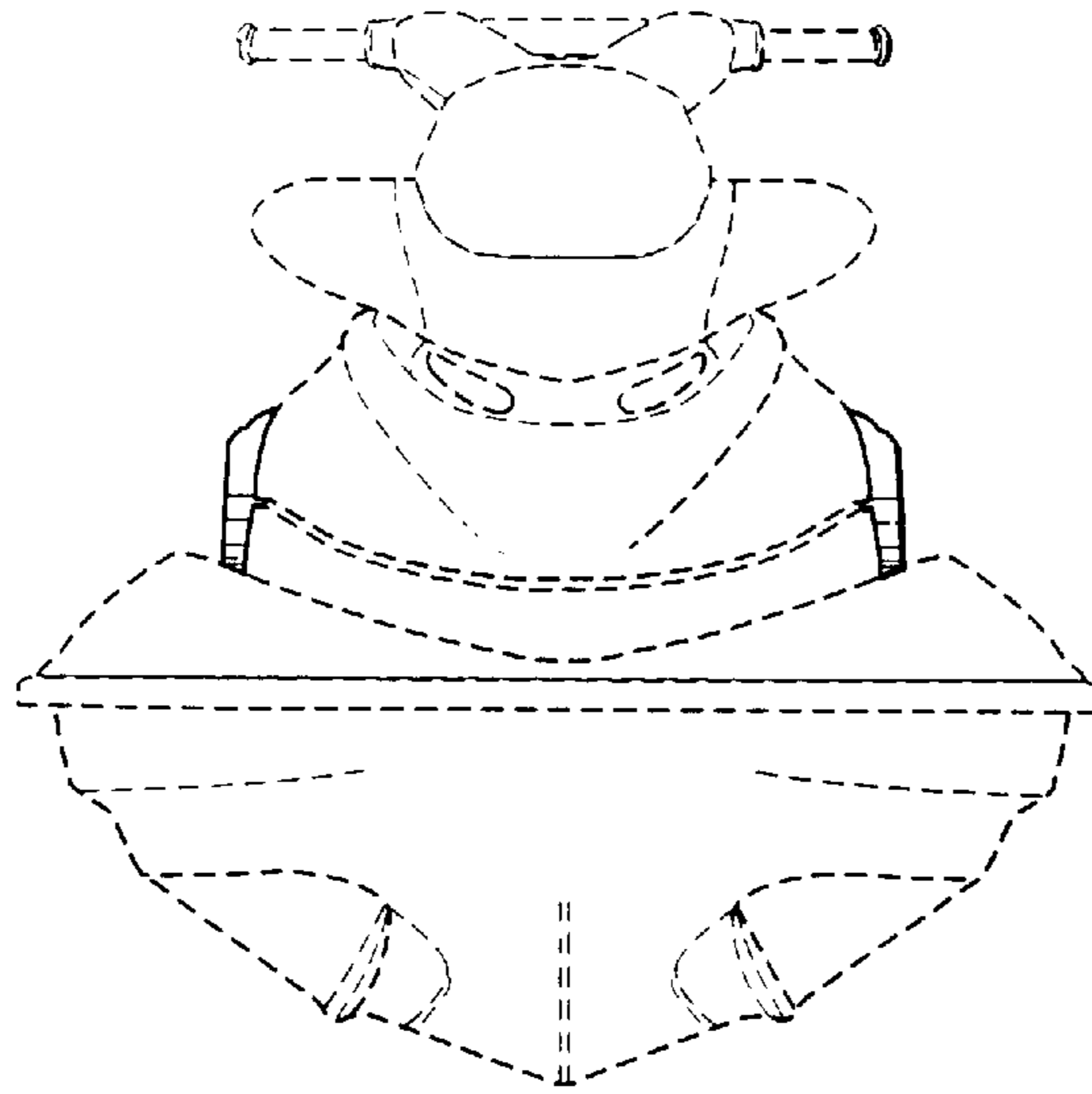

Fig. 12

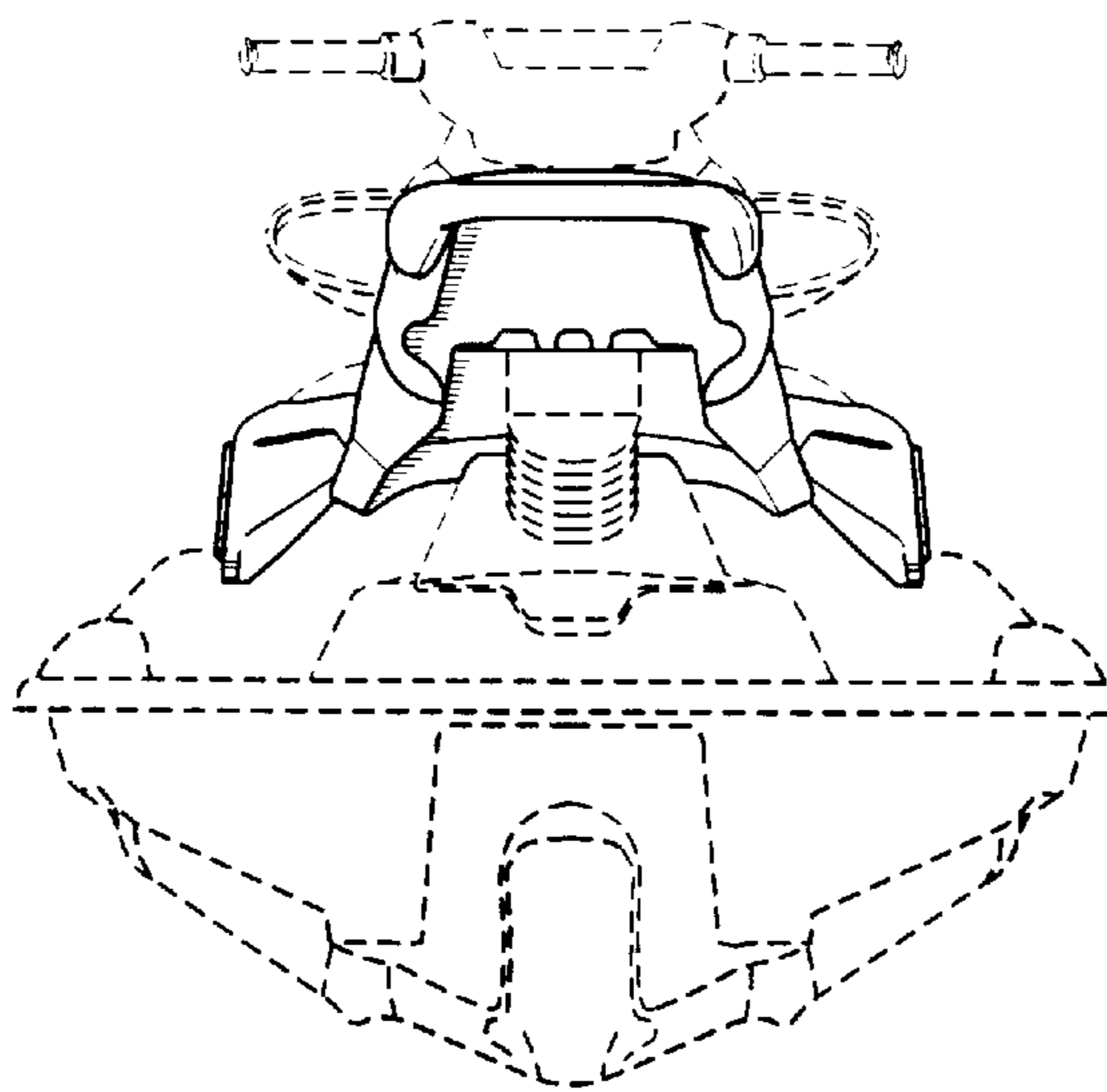

Fig. 13

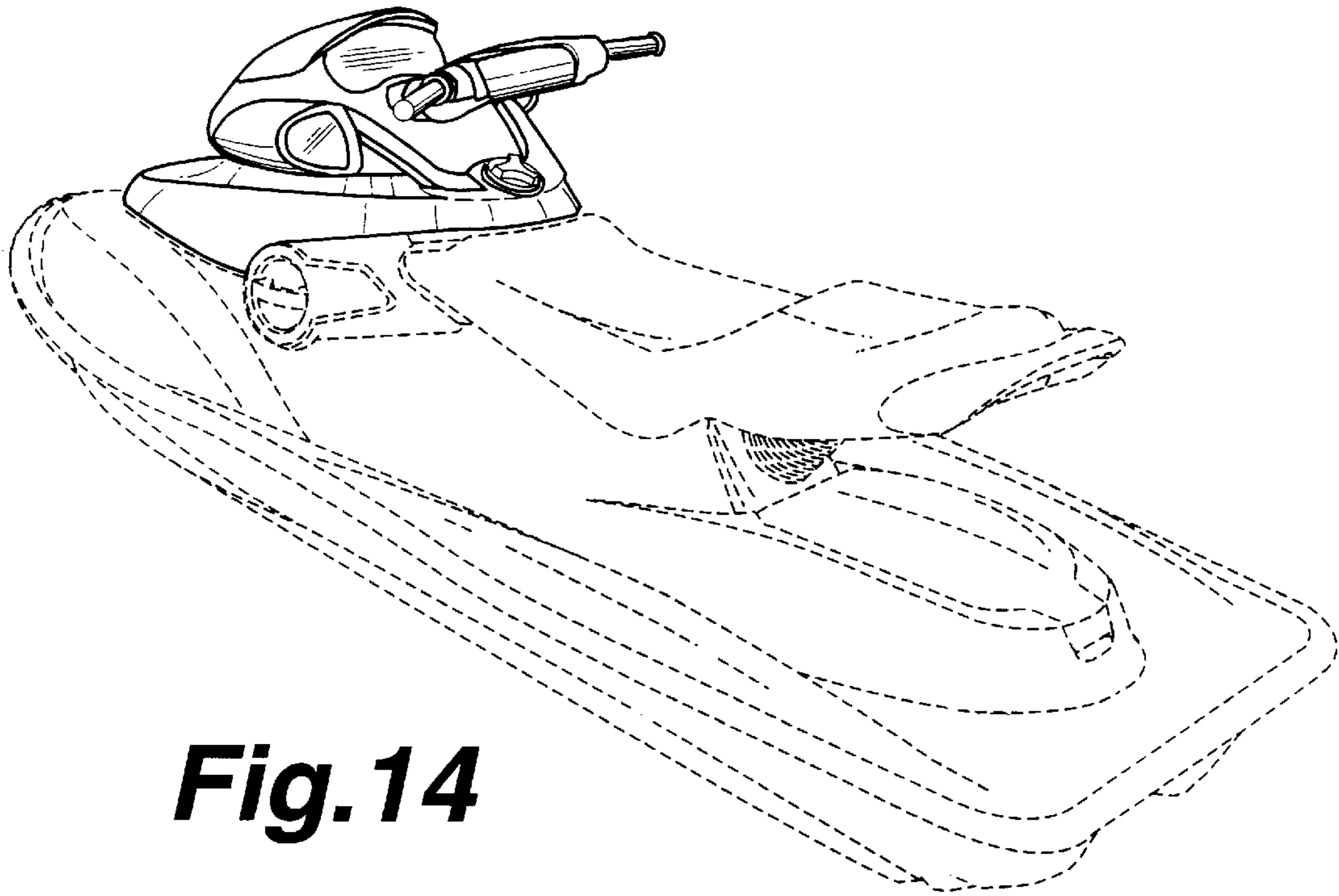

Fig. 14

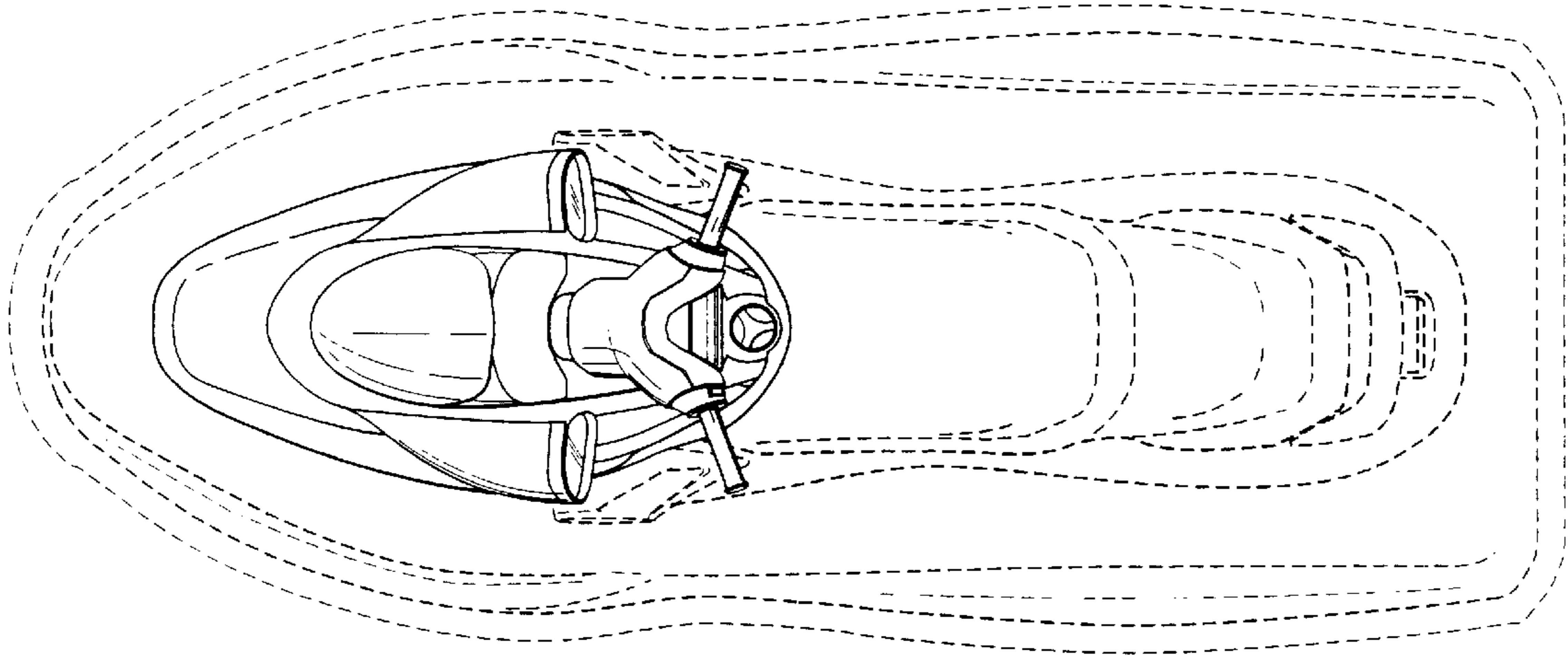

Fig. 15

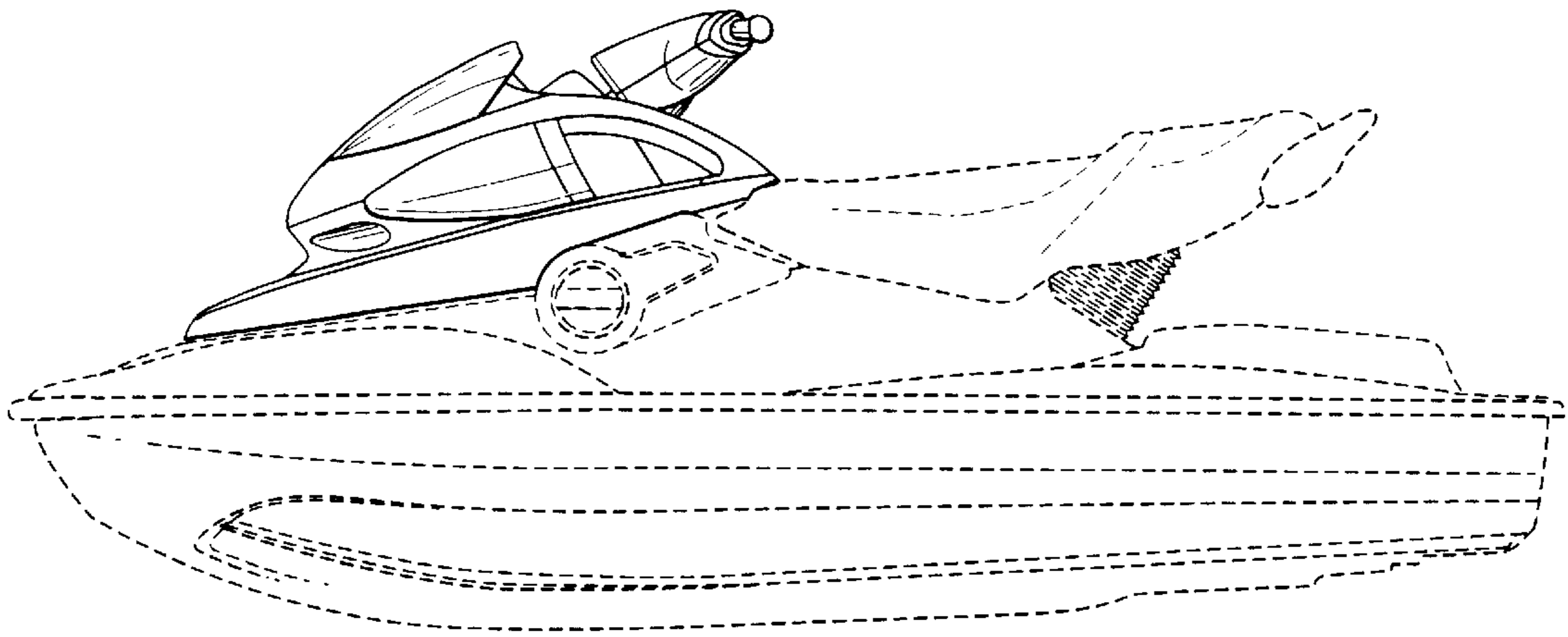

Fig.16

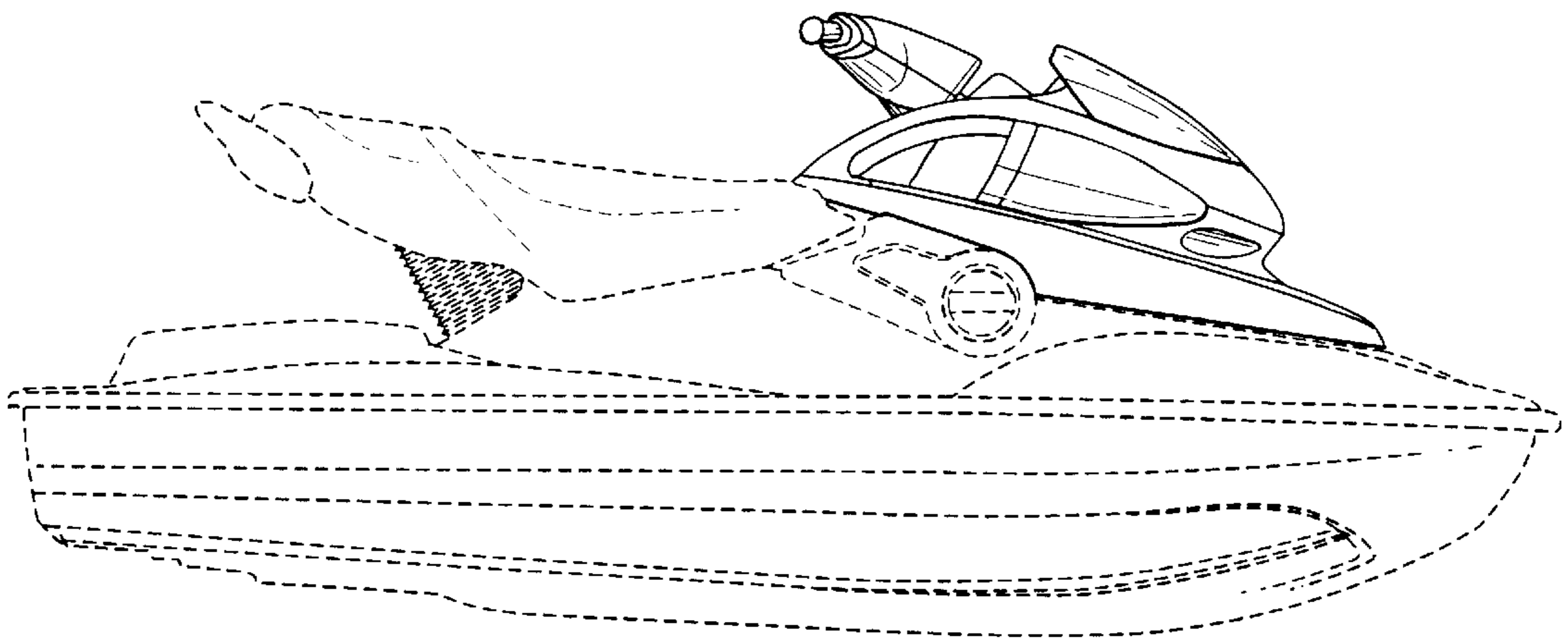

Fig.17

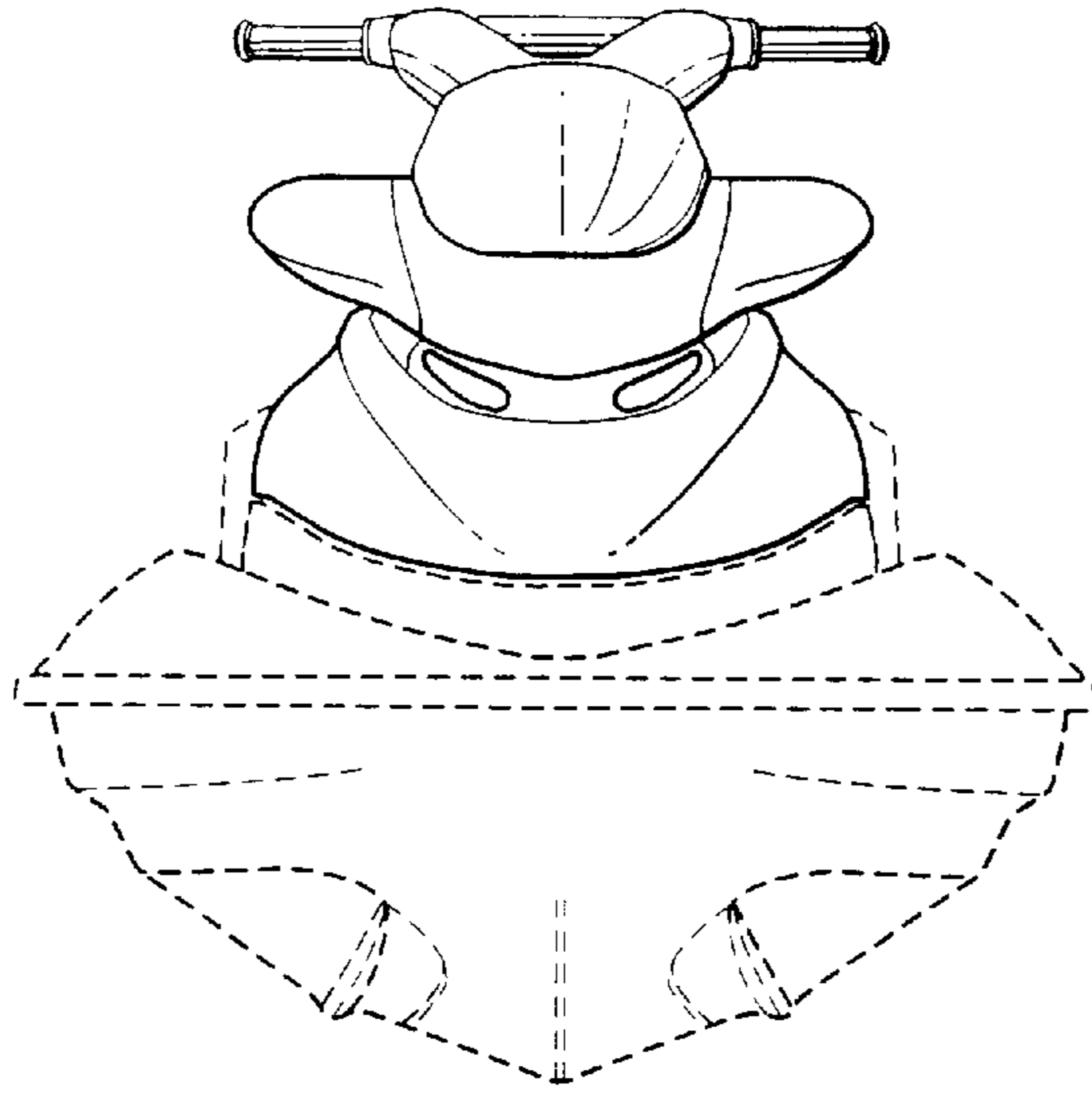

Fig. 18

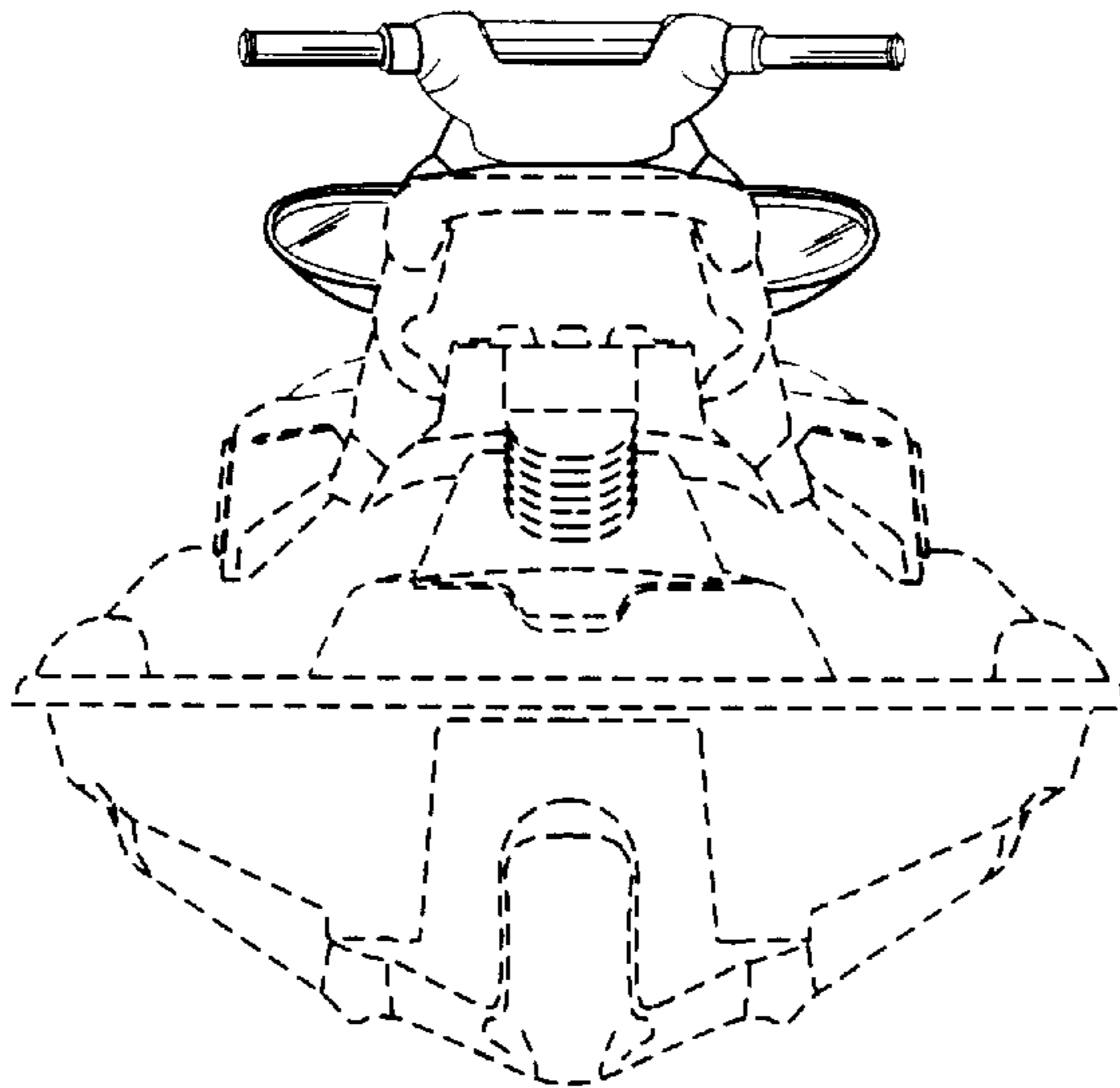

Fig. 19

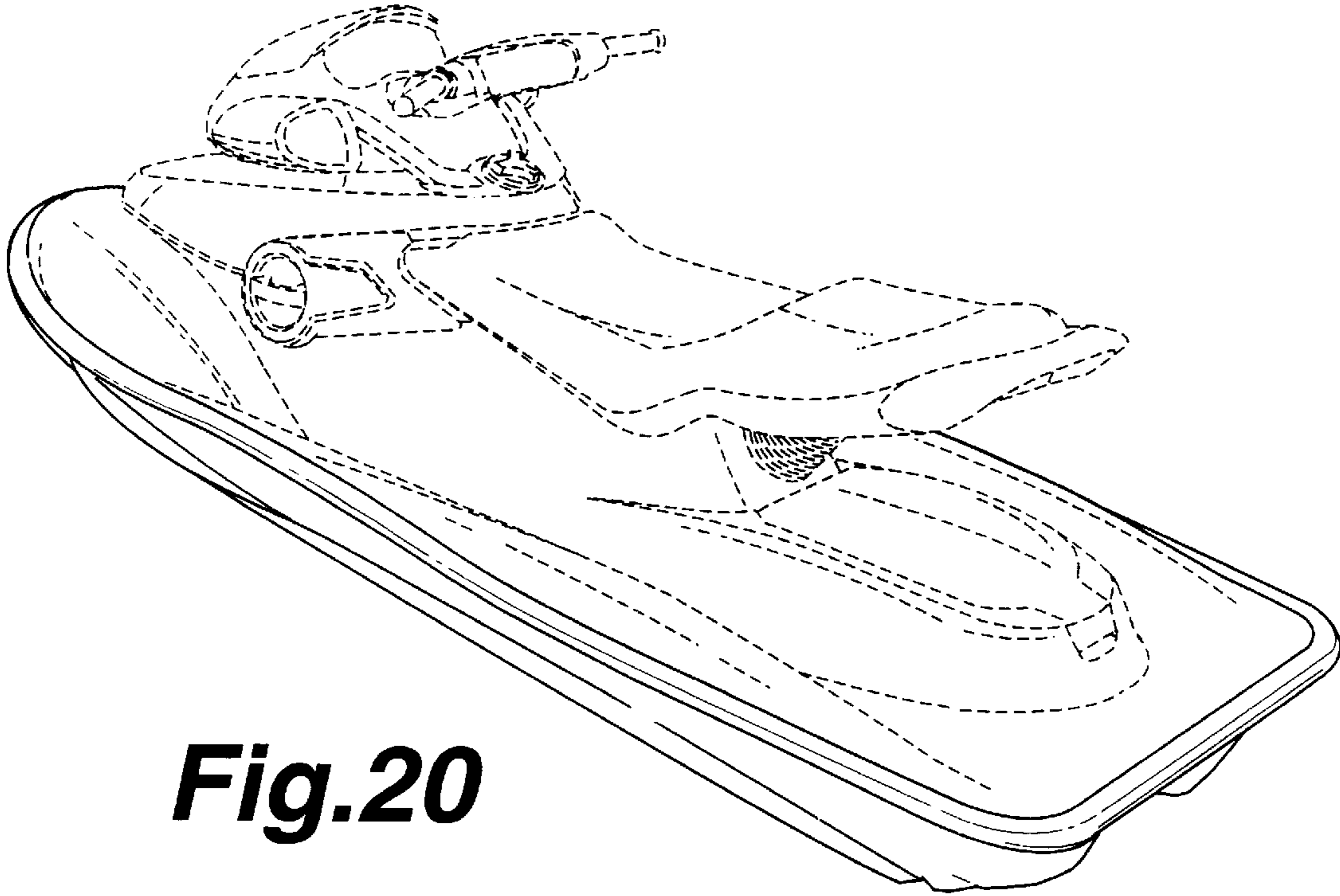

Fig.20

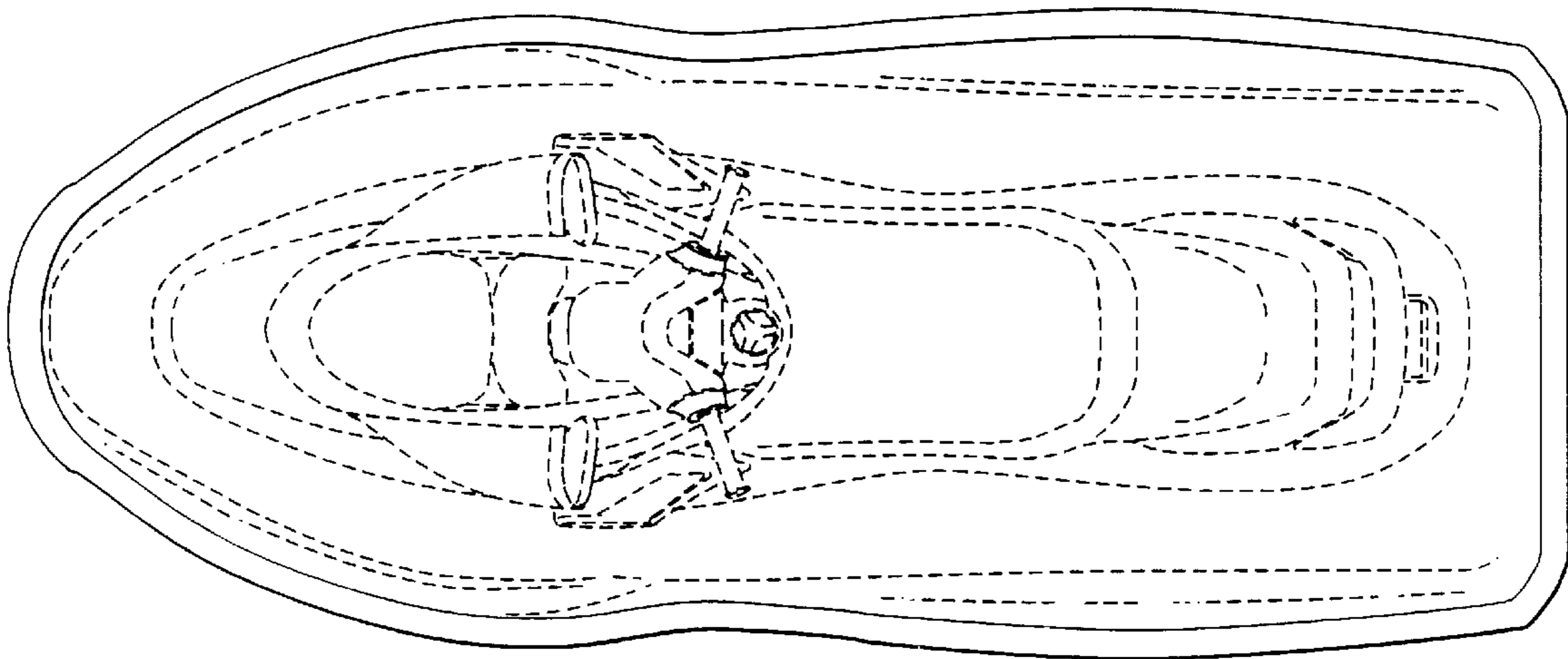

Fig.21

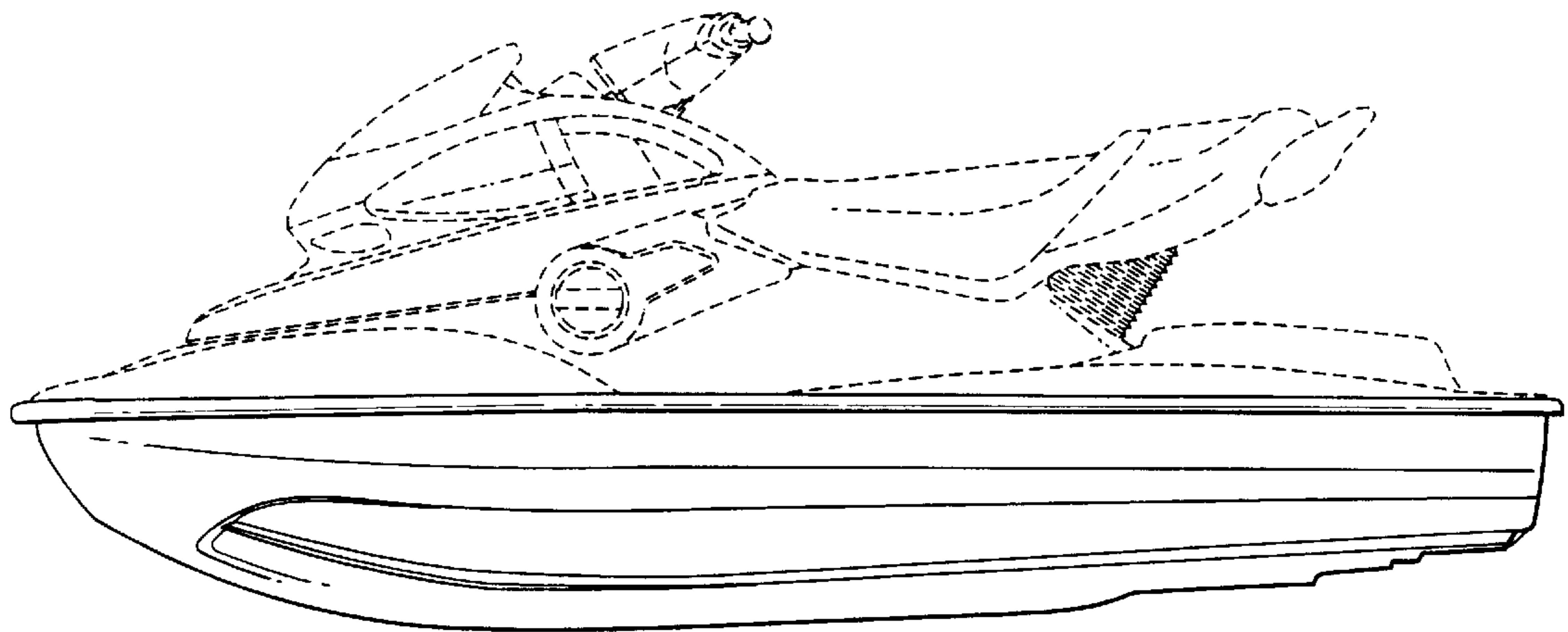

Fig.22

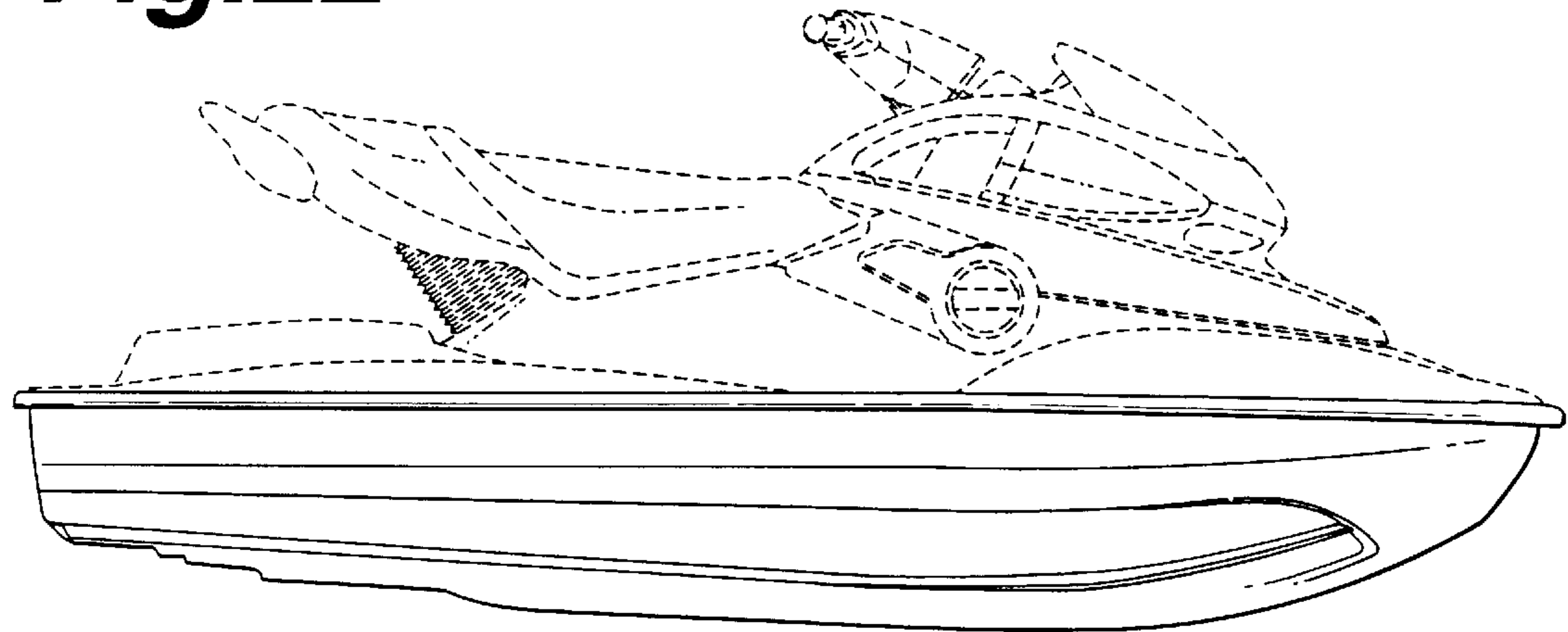

Fig.23

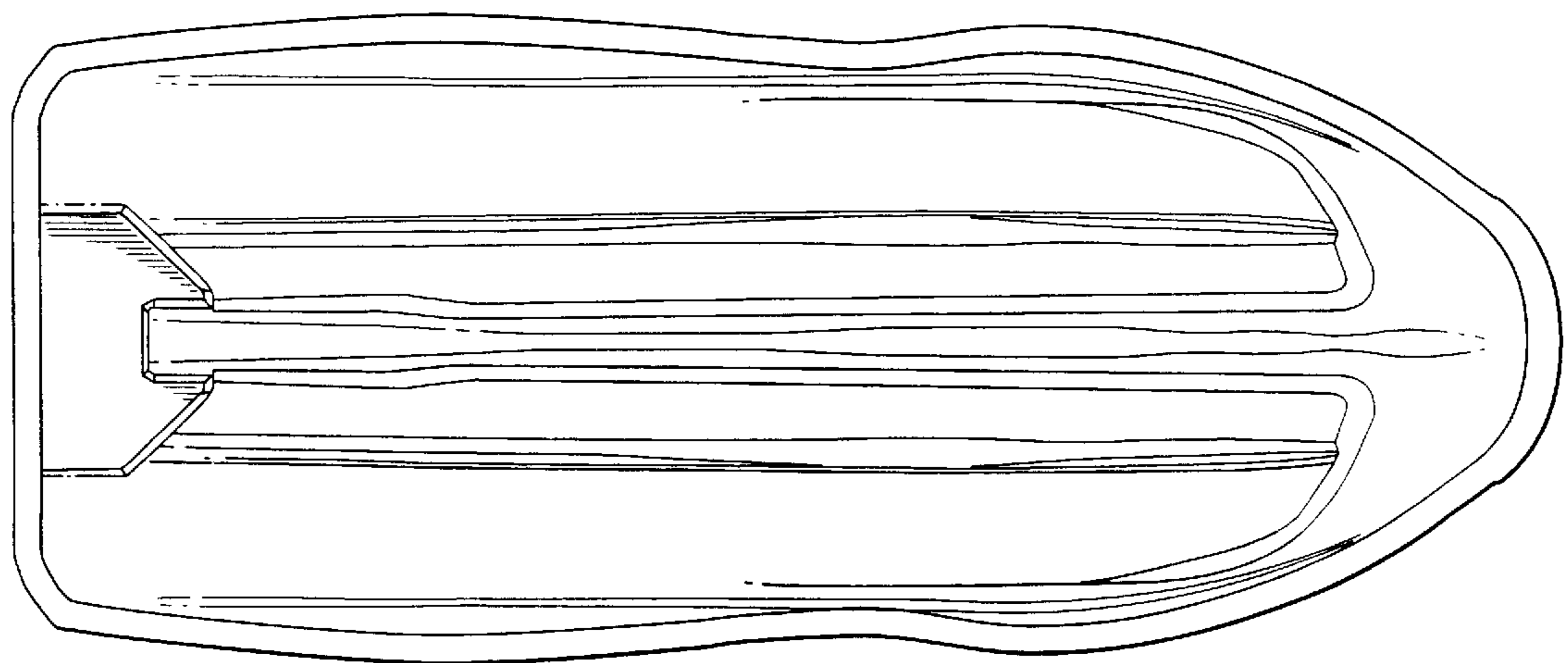

Fig.24

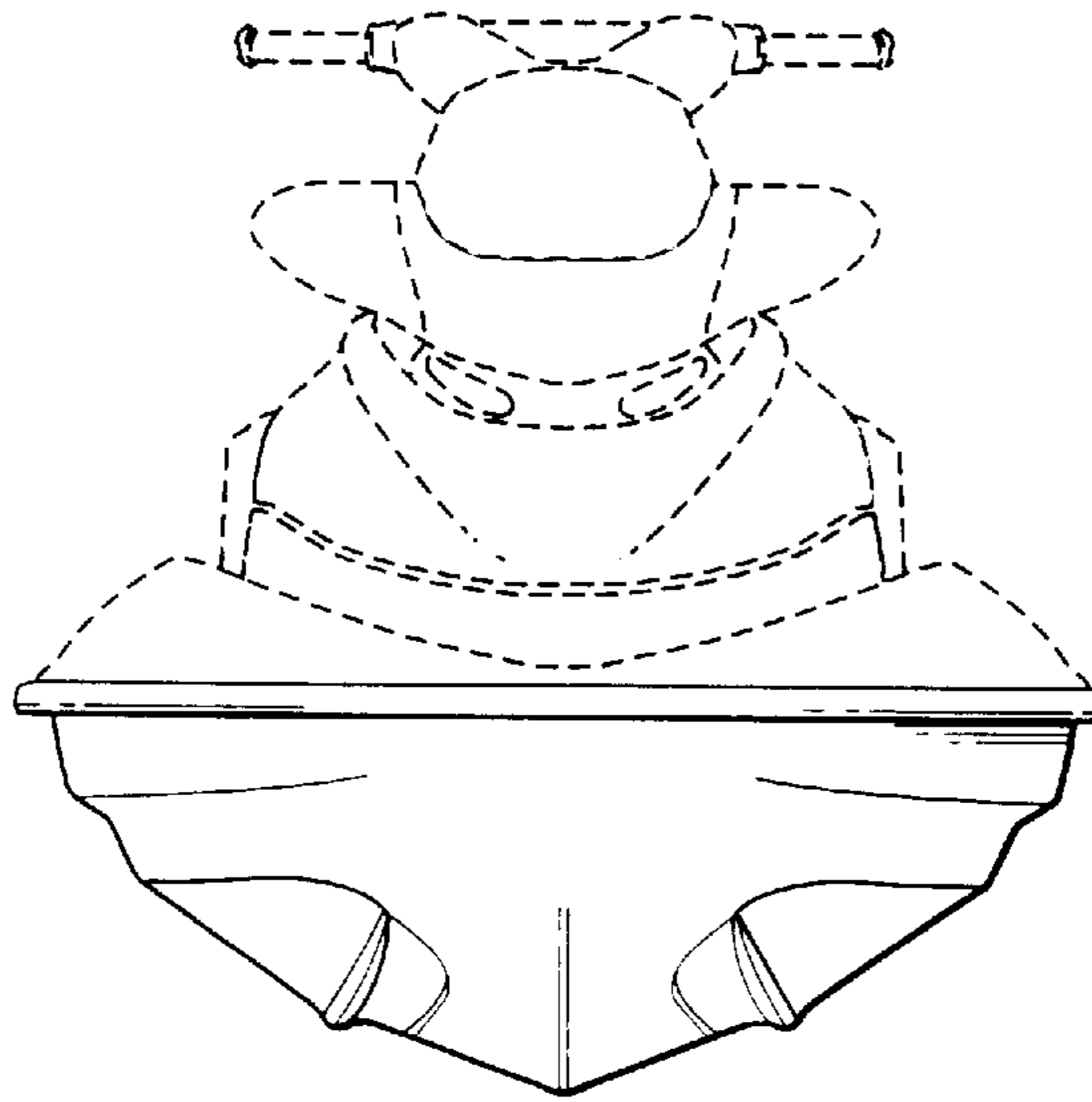

Fig.25

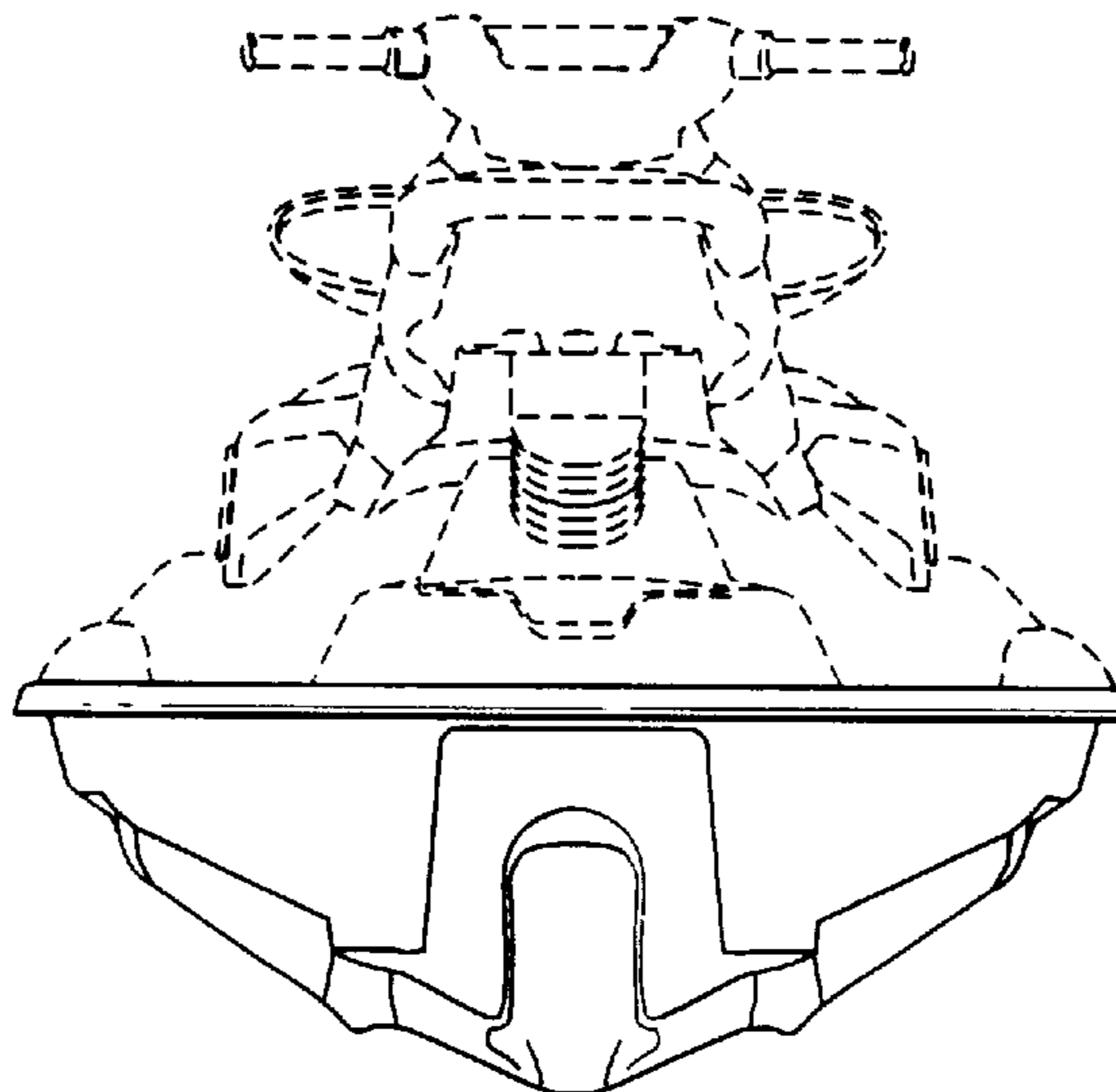

Fig.26