



US00D399173S

United States Patent [19]

Herner et al.

[11] **Patent Number: Des. 399,173**

[45] **Date of Patent: **Oct. 6, 1998**

[54] **AUTOMOBILE**

D. 379,946 6/1997 Tanabe et al. D12/92

[75] Inventors: **Don Herner**, Rancho Palos Verdes;
Kouichirou Fujii, Torrance, both of
Calif.

Primary Examiner—Melody N. Brown
Attorney, Agent, or Firm—Birch, Stewart, Kolasch & Birch,
LLP

[73] Assignee: **Honda Giken Kogyo Kabushiki
Kaisha**, Tokyo, Japan

[57] **CLAIM**

[**] Term: **14 Years**

We claim the ornamental design for an automobile, as shown
and described.

[21] Appl. No.: **75,265**

[22] Filed: **Aug. 29, 1997**

DESCRIPTION

[51] **LOC (6) Cl. 12-08**

[52] **U.S. Cl. D12/92**

[58] **Field of Search D12/90, 92; 296/185**

FIG. 1 is a right, front, perspective view of the automobile
showing our new design;
FIG. 2 a right, rear, perspective view of the automobile
showing our new design;
FIG. 3 is a right-side, elevational view of the automobile of
FIG. 1, the left-side being essentially a mirror image thereof;
FIG. 4 is a front, elevational view of the automobile of FIG.
1;
FIG. 5 is a rear, elevational view of the automobile of FIG.
1; and,
FIG. 6 is a top plan view of the automobile of FIG. 1.
The bottom of the automobile is unornamented.

[56] **References Cited**

U.S. PATENT DOCUMENTS

D. 354,458	1/1995	Daikoku	D12/92
D. 357,211	4/1995	Choi	D12/92
D. 373,332	9/1996	Udagawa et al.	D12/92
D. 373,333	9/1996	Ishibashi et al.	D12/92
D. 373,334	9/1996	Honda et al.	D12/92

1 Claim, 6 Drawing Sheets

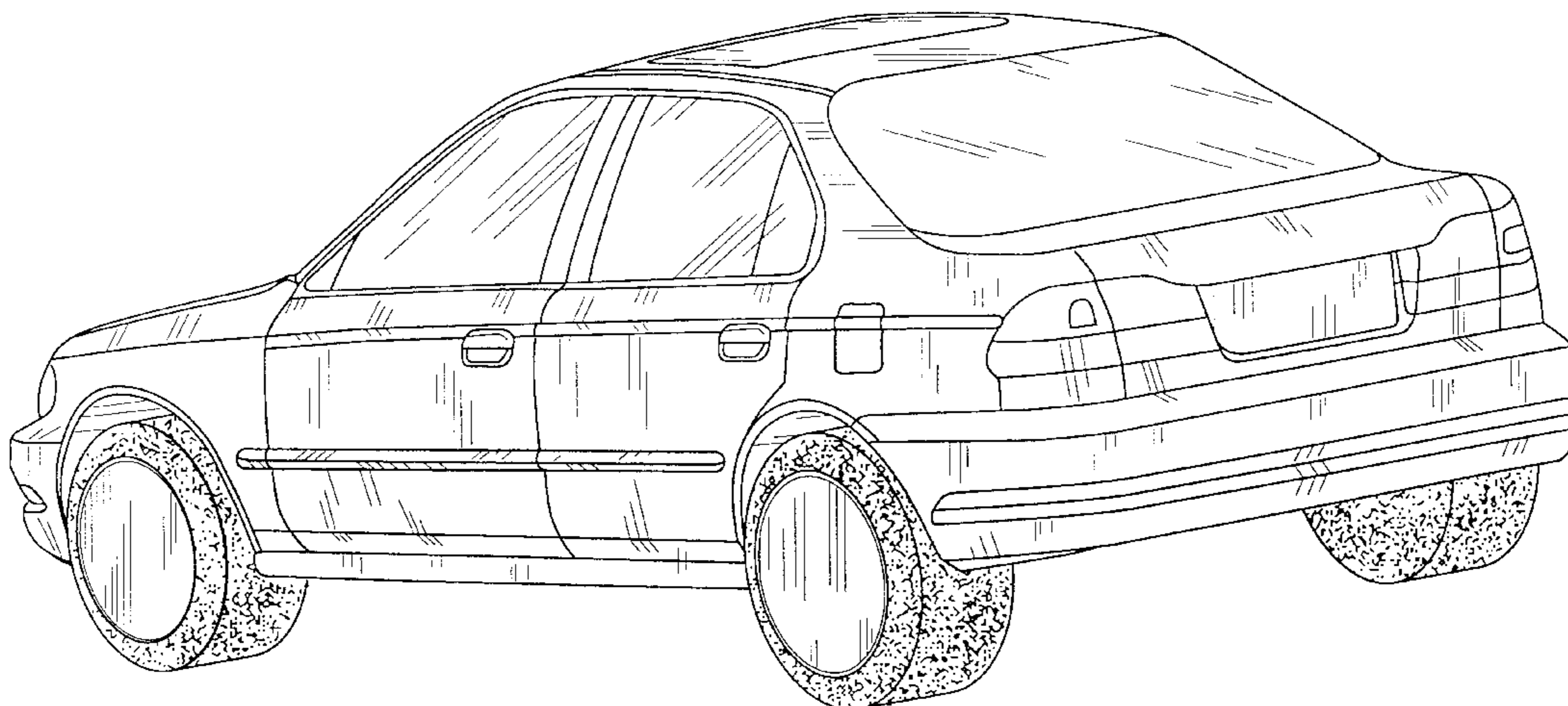
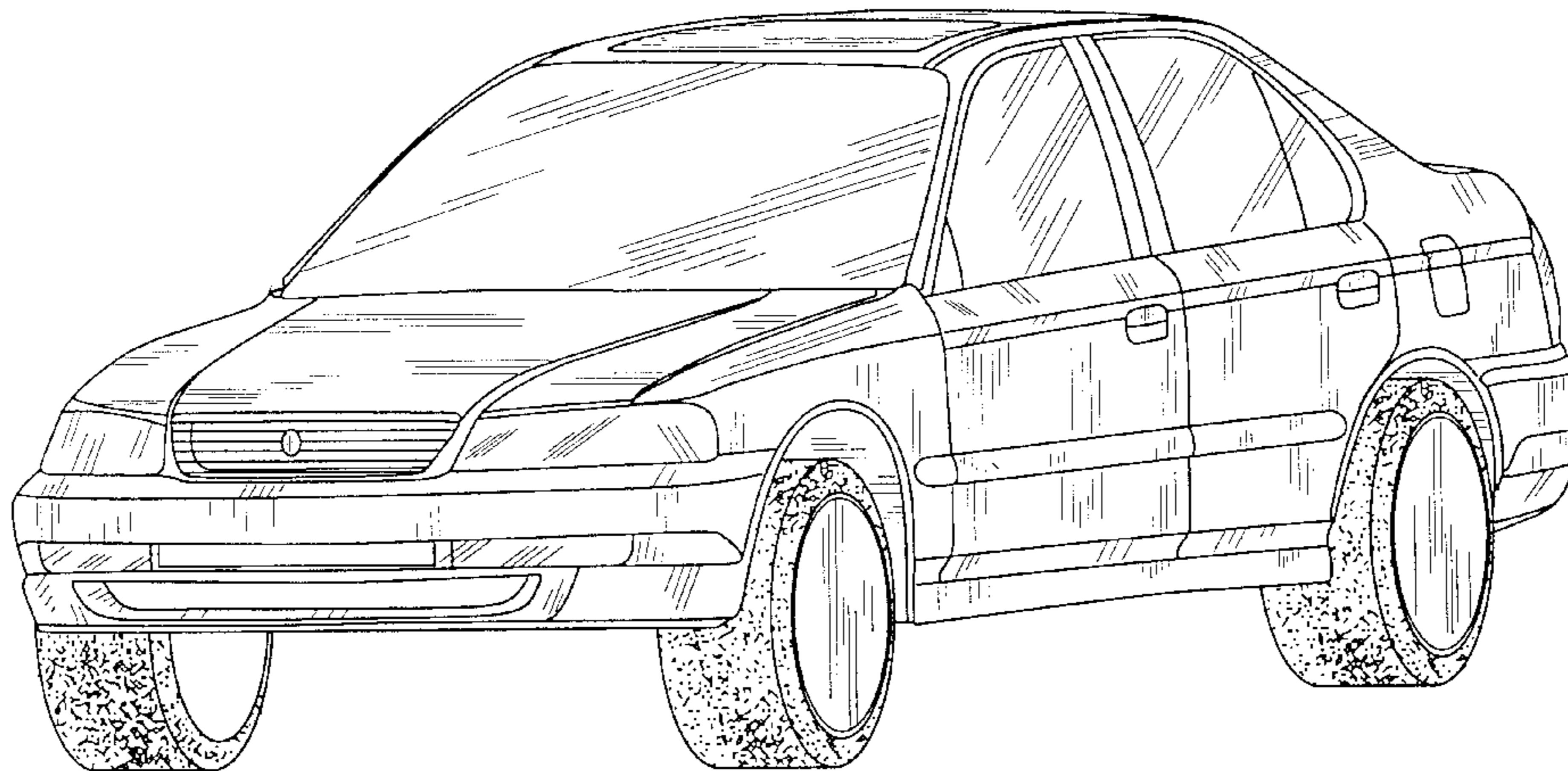

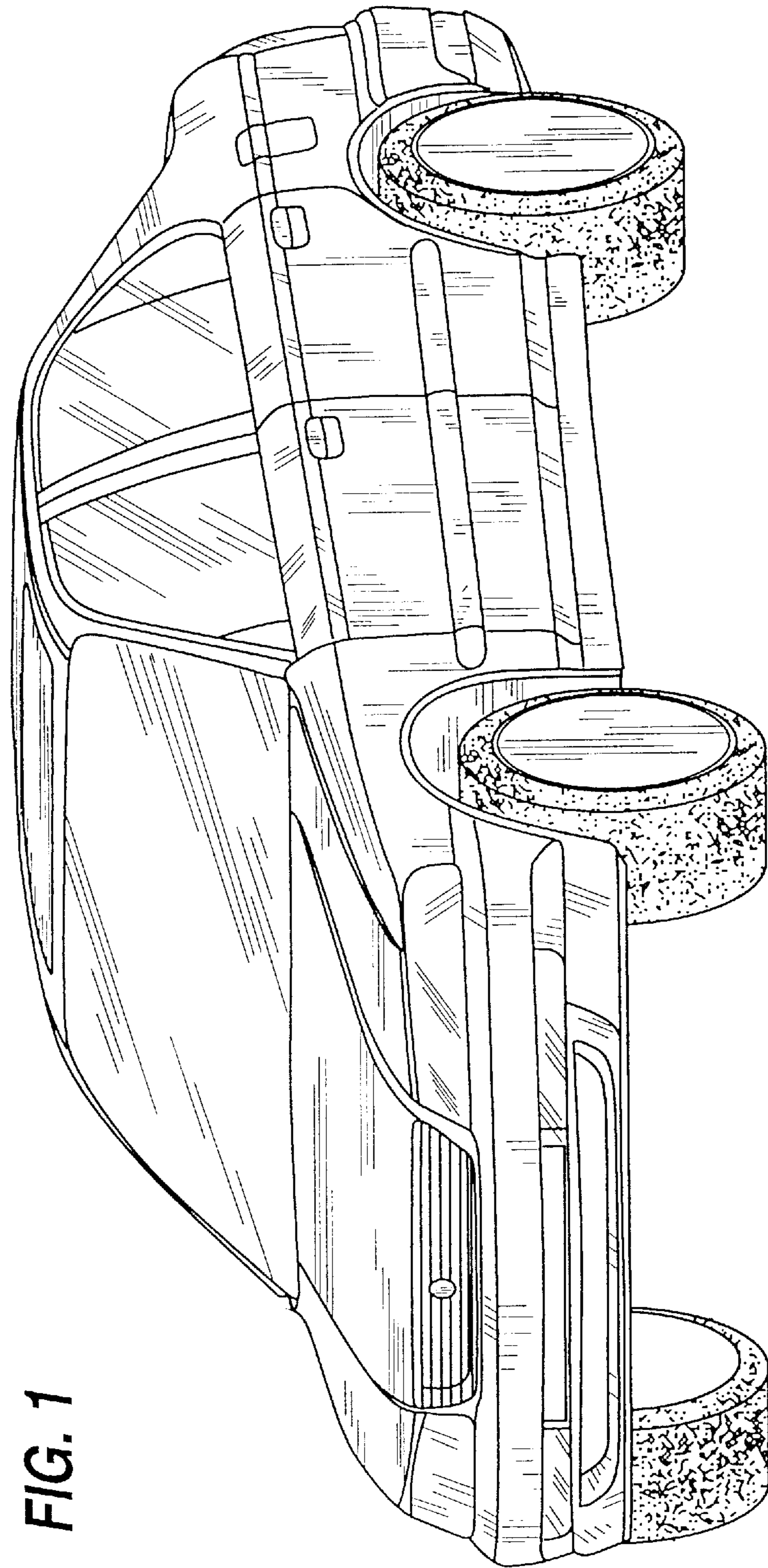

FIG. 1

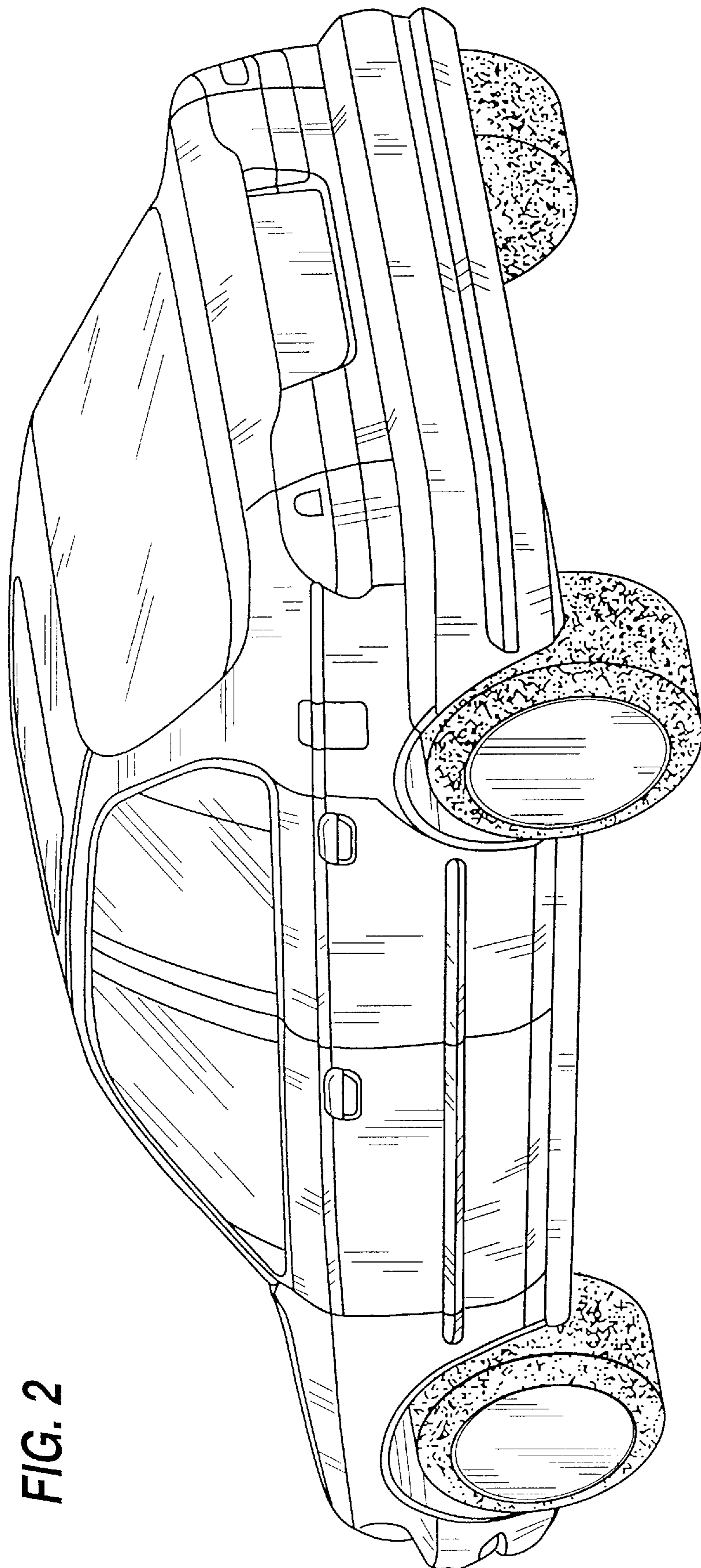

FIG. 2

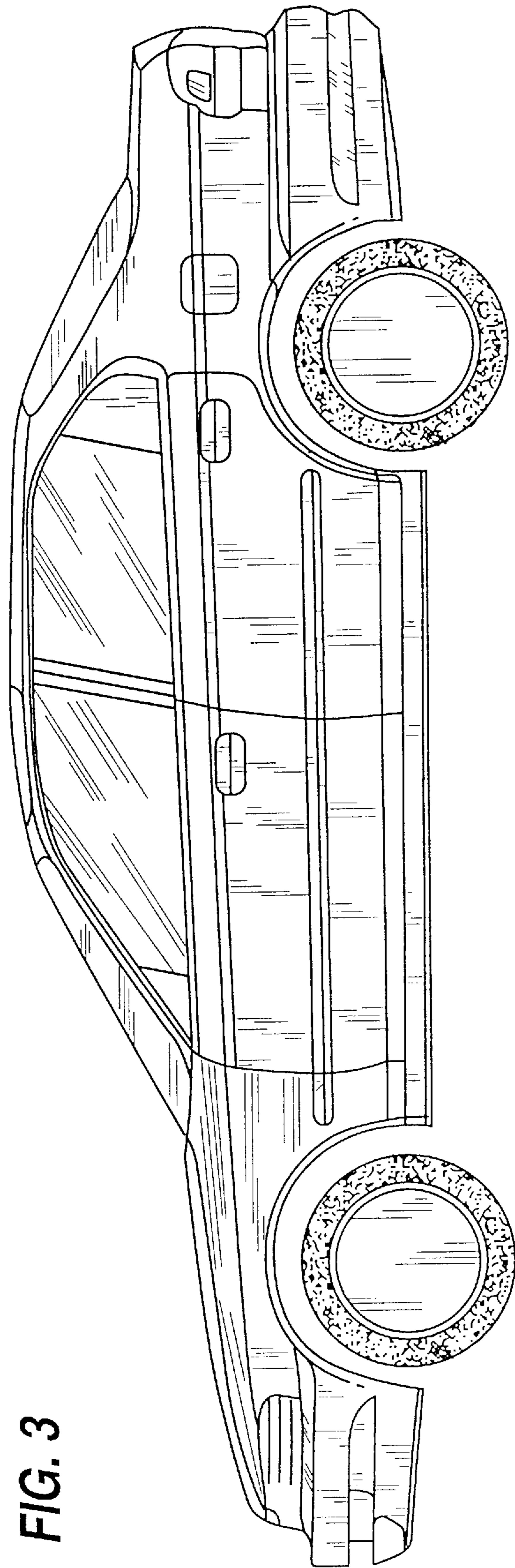

FIG. 3

FIG. 4

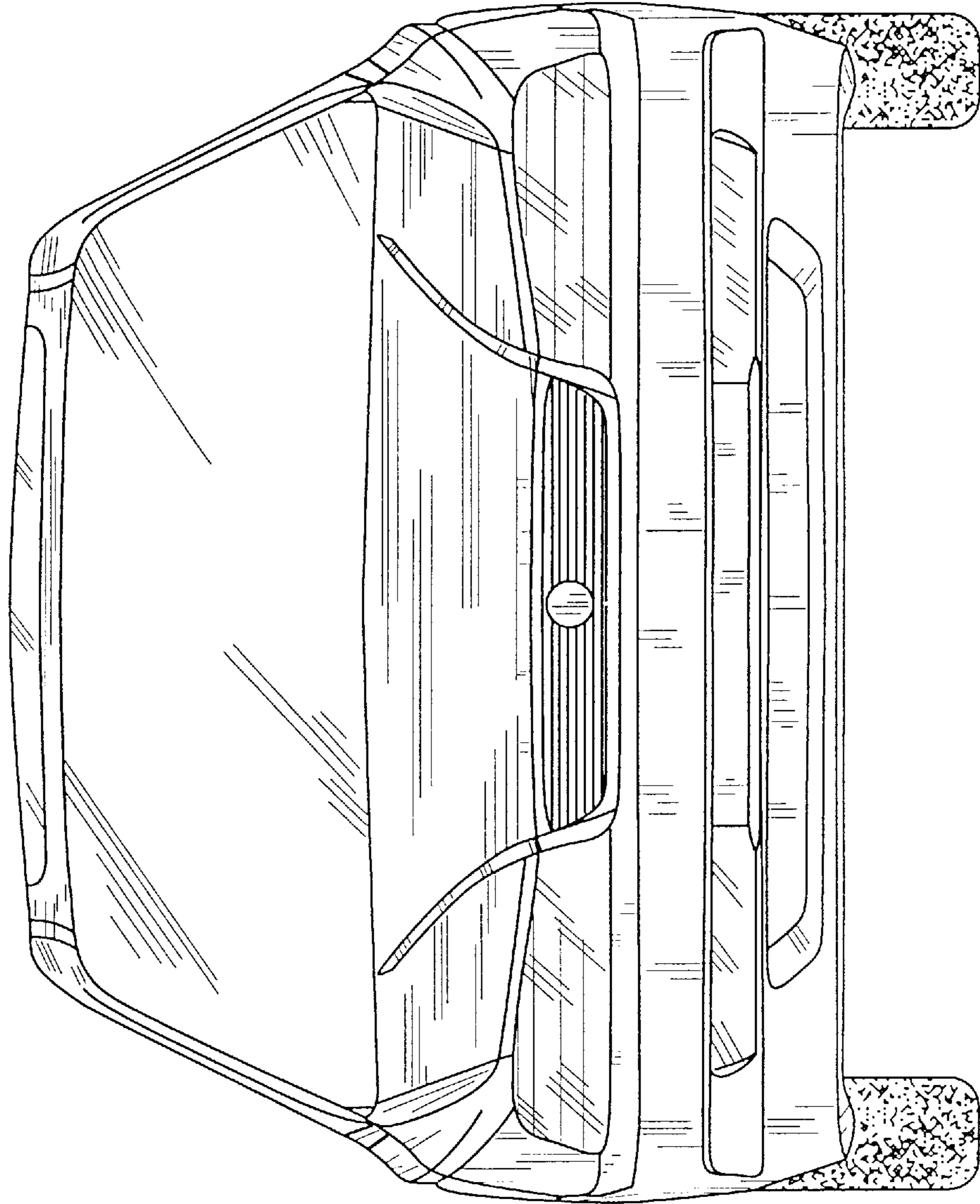

FIG. 5

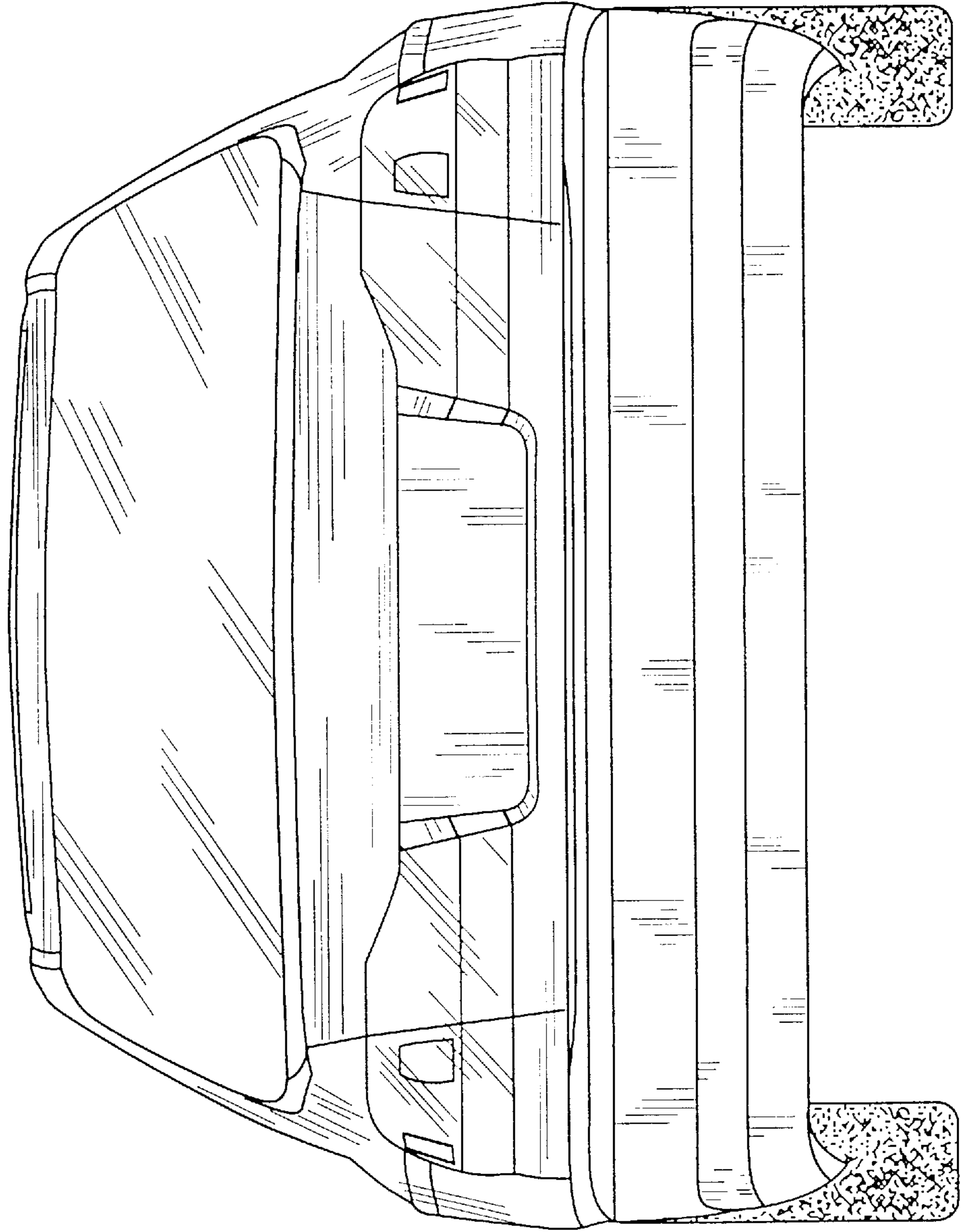

FIG. 6

