



US00D399121S

# United States Patent [19]

Alyanakian et al.

[11] Patent Number: Des. 399,121

[45] Date of Patent: \*\*Oct. 6, 1998

## [54] SLIDE LATCH

[75] Inventors: **Robert D. Alyanakian**, West Chester;  
**Peter W. Bressler**; **John D. Coleman**,  
both of Philadelphia, all of Pa.

[73] Assignee: **Southco, Inc.**, Concordville, Pa.

[\*\*] Term: **14 Years**

[21] Appl. No.: **64,685**

[22] Filed: **Jan. 8, 1997**

[51] **LOC (6) Cl.** ..... **08-07**

[52] **U.S. Cl.** ..... **D8/339**

[58] **Field of Search** ..... D8/330, 331, 336,  
D8/338, 339, 300, 302, 306; 70/77-79,  
91, 101, 102; 292/57, 80, 95, 121, 137,  
163, 177, DIG. 11, DIG. 12

## [56] References Cited

### U.S. PATENT DOCUMENTS

137,211	3/1873	Jones .	
D. 208,088	7/1967	Banner .	
D. 230,132	1/1974	Pastva, Jr. .	
D. 314,131	1/1991	Russell et al. ....	D8/300 X
D. 342,636	12/1993	Schlack et al. .	
D. 369,089	4/1996	Zenner .....	D8/331 X
D. 370,620	6/1996	Ziemer .....	D8/331 X
824,780	7/1906	Ecker .	
2,987,908	6/1961	Pelcin .....	D8/331 X
3,389,932	6/1968	Pastva, Jr. .	
3,841,674	10/1974	Bisbing et al. .	
3,850,464	11/1974	Bisbing et al. .	
4,790,579	12/1988	Maxwell et al. .	
5,096,240	3/1992	Schultz .	
5,121,951	6/1992	Harbum et al. .	

## FOREIGN PATENT DOCUMENTS

2386670 12/1978 France .  
1184431 6/1968 United Kingdom .

## OTHER PUBLICATIONS

U.S. application No. 08/048,126, Alyanakian, filed Apr. 1993.

U.S. applicaton No. 29/007,318, Alyanakian et al., filed Apr. 1993.

DZUS Catalogue, p. 35, Series 404 Latch.

Camloc Catalogue, p. F-95, PTL30 Series Latch.

Eberhard Catalogue No. 103 (1985) Section 1, p. 87, Slam Latch No. 4821.

Southco Latches and Access Hardware Handbook 43 (1993) pp. G-3, G-6, G-18 and G-19.

*Primary Examiner*—Brian N. Vinson

*Attorney, Agent, or Firm*—Paul & Paul

## [57] CLAIM

The ornamental design for a slide latch, as shown and described.

## DESCRIPTION

FIG. 1 is a perspective view a slide latch embodying our design;

FIG. 2 is a top plan view thereof;

FIG. 3 is a front elevational view thereof, the rear elevational view being a mirror image of that shown; and,

FIG. 4 is a right side elevational view thereof, the left side elevational view being a mirror image of that shown.

The broken lines showing a panel in which the slide latch is mounted is for illustrative purposes only and forms no part of the claimed design.

**1 Claim, 1 Drawing Sheet**

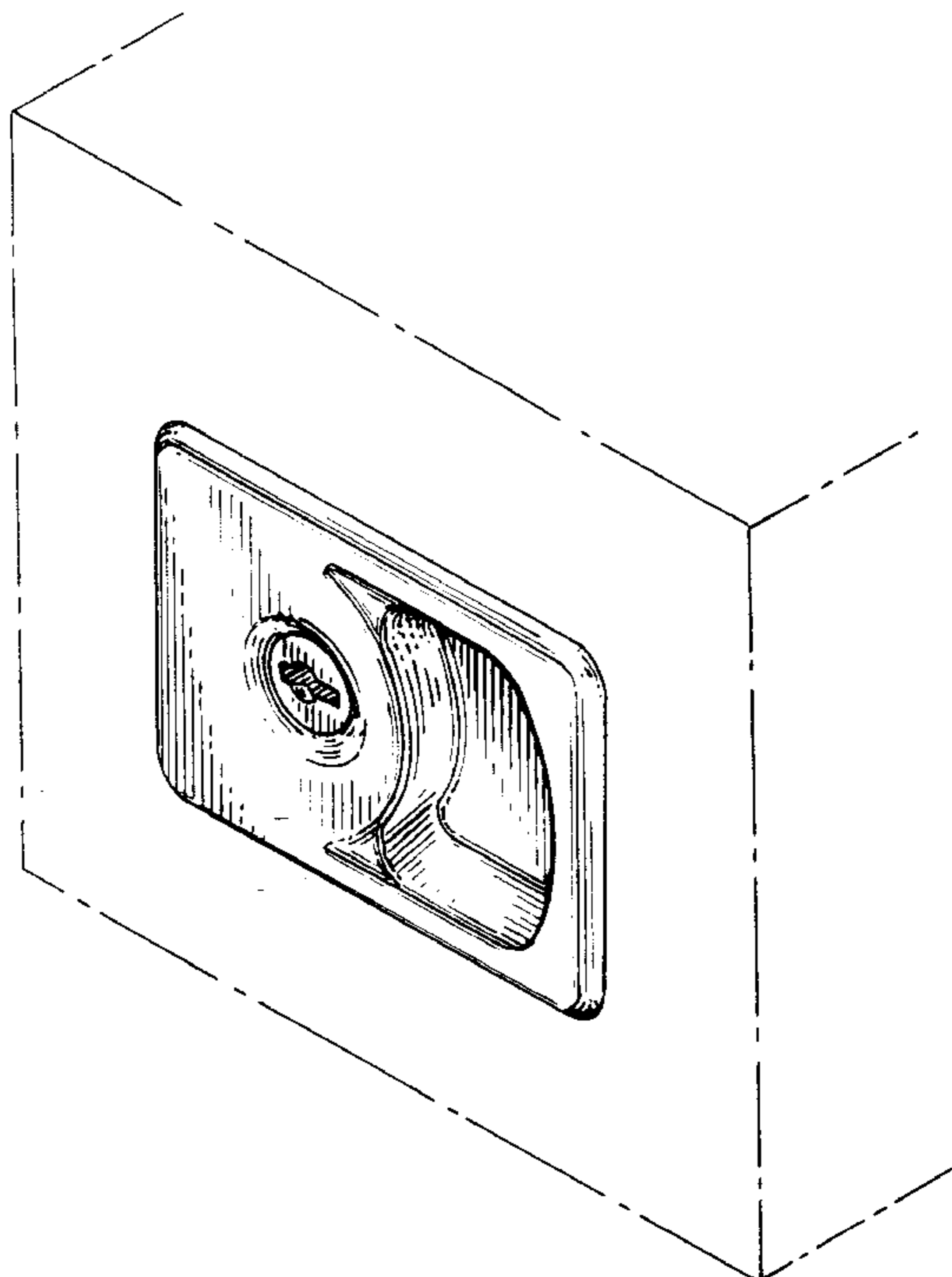

***Fig. 1***

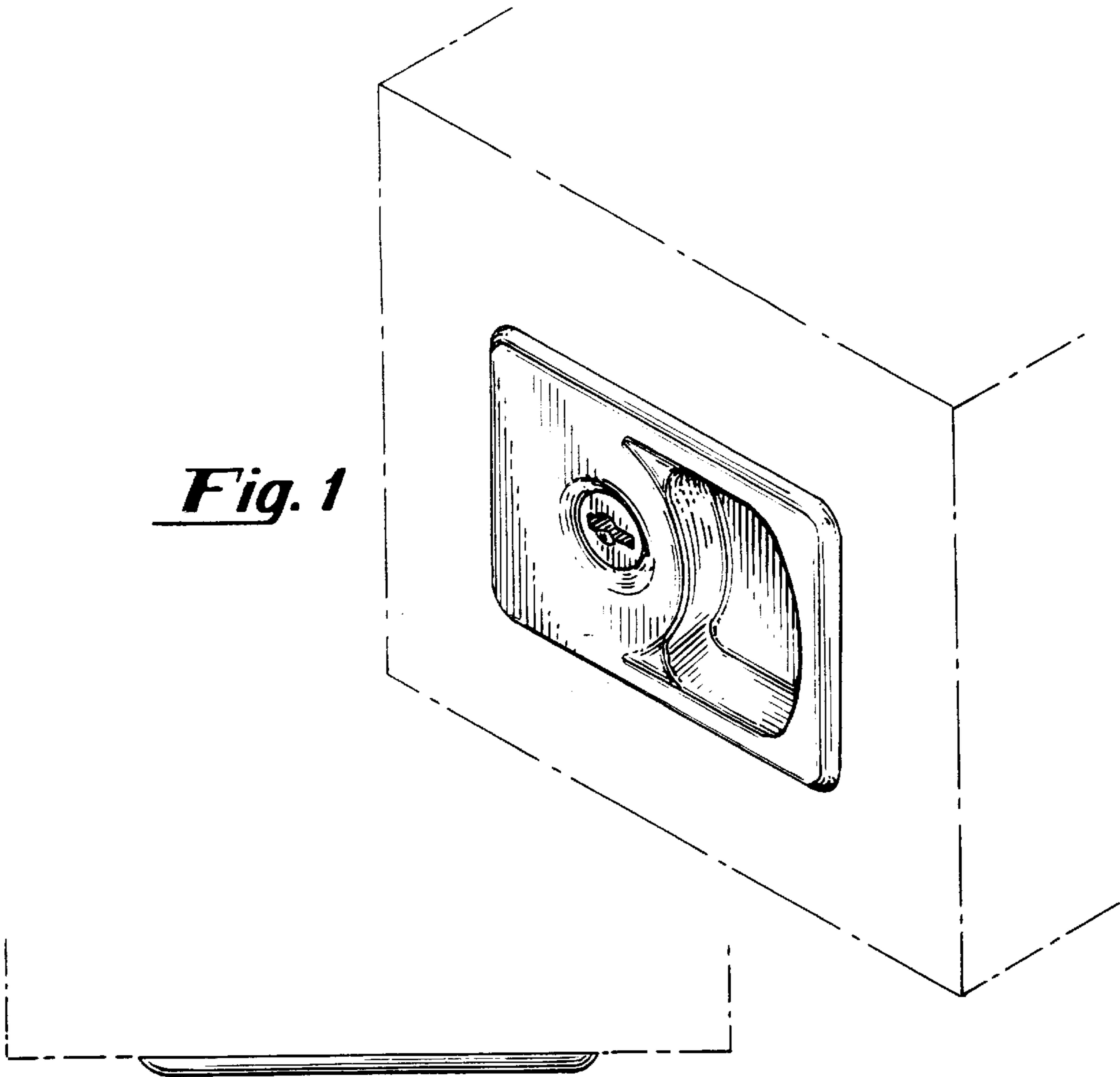

***Fig. 2***

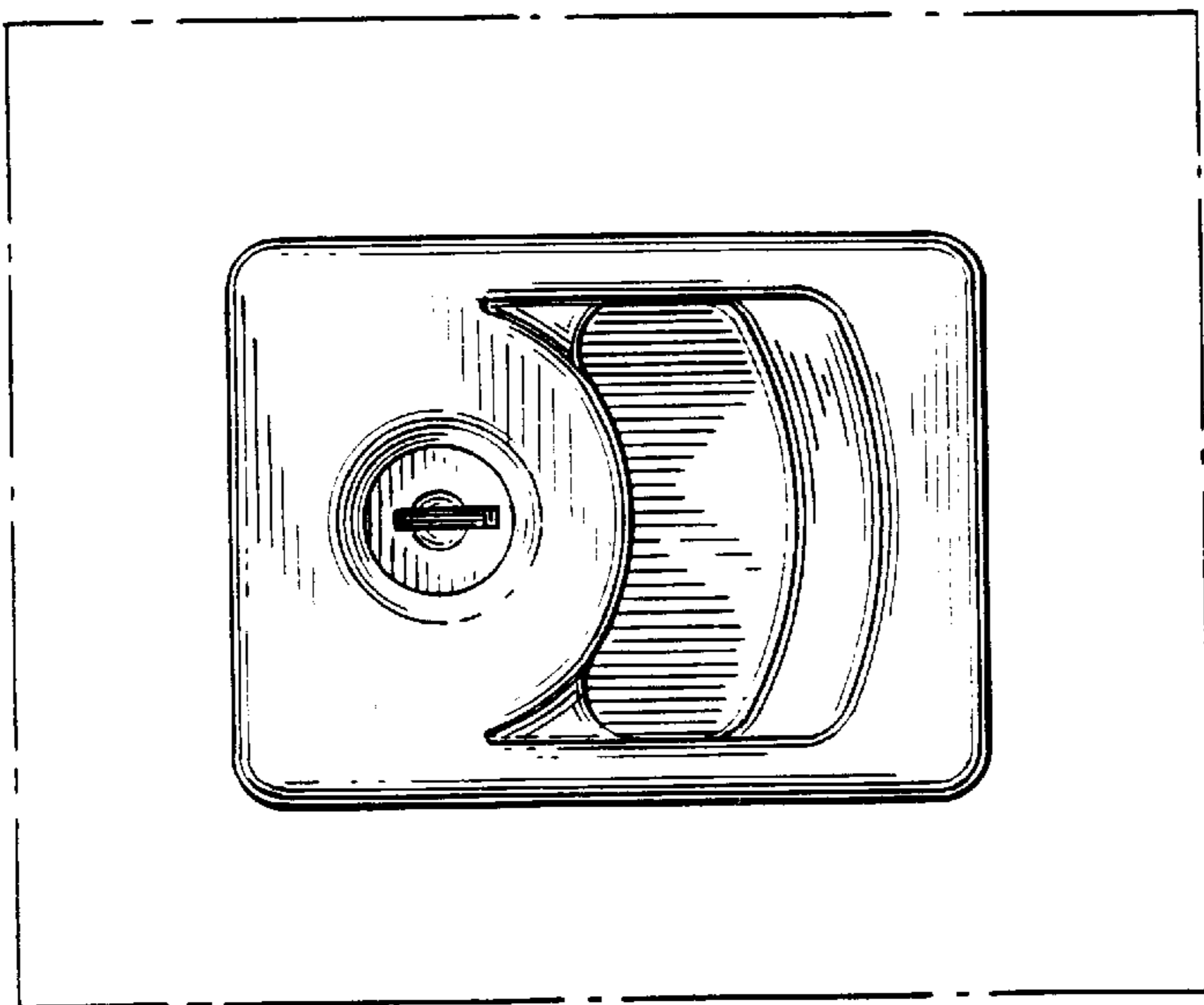

***Fig. 3***

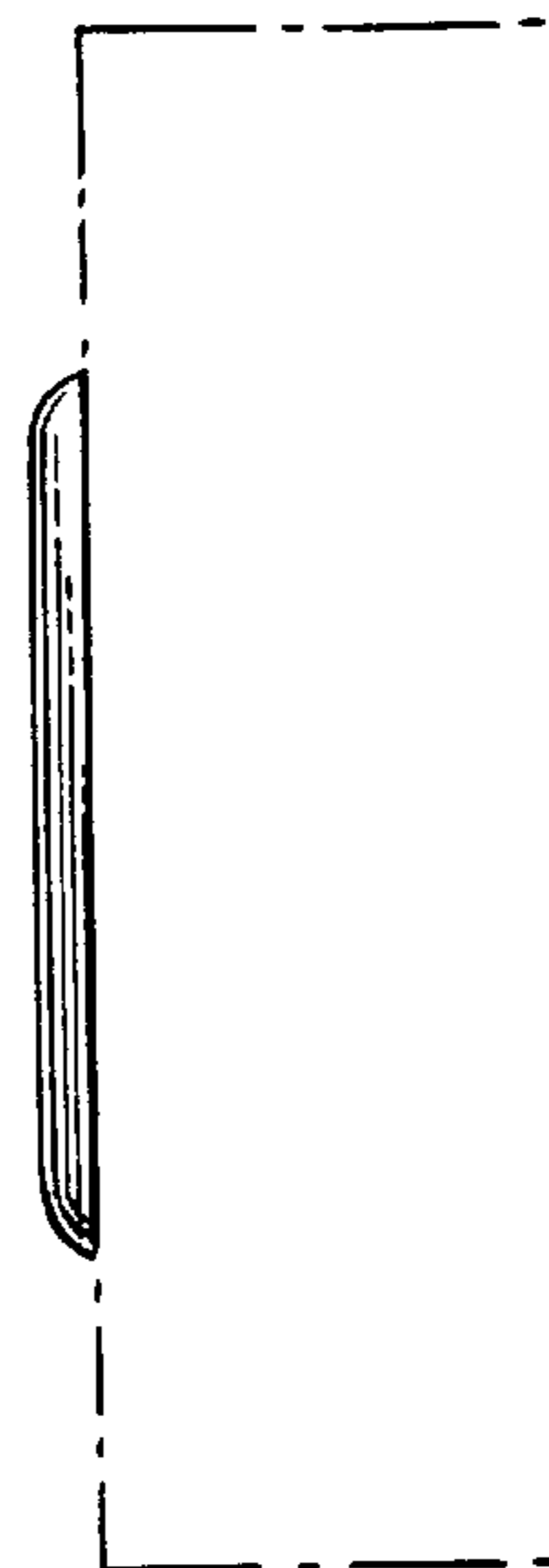

***Fig. 4***