



US00D398988S

United States Patent [19] Nash

[11] Patent Number: **Des. 398,988**

[45] Date of Patent: ****Sep. 29, 1998**

[54] **CARTRIDGE DISPENSER**

[75] Inventor: **James E. Nash**, St. Paul, Minn.

[73] Assignee: **Minnesota Mining & Manufacturing Co.**, St. Paul, Minn.

[**] Term: **14 Years**

[21] Appl. No.: **35,390**

[22] Filed: **Feb. 27, 1995**

[51] **LOC (6) Cl.** **29-02**

[52] **U.S. Cl.** **D24/113**

[58] **Field of Search** D24/176, 128,
D24/113, 108, 114; 604/125, 124, 118,
224; 403/24; 433/89; 222/326, 329; 219/230

[56] **References Cited**

U.S. PATENT DOCUMENTS

D. 277,134	1/1985	Dragan	D24/114
D. 357,536	4/1995	Dragan et al.	D24/176
D. 359,560	6/1995	Mitchell	D24/176
3,598,293	8/1971	Lee	222/327
4,065,034	12/1977	Callan	219/230
4,081,112	3/1978	Chang	222/391
4,198,756	4/1980	Dragan	222/326
4,260,077	4/1981	Schroeder	222/137
4,339,058	7/1982	Wendt	222/326 X
4,340,367	7/1982	Vadas et al.	433/89
4,366,919	1/1983	Anderson	222/137
4,444,560	4/1984	Jacklich	604/224
4,471,888	9/1984	Herb et al.	222/391
4,472,141	9/1984	Dragan	433/90
4,479,781	10/1984	Herold et al.	433/90
4,509,662	4/1985	Weiss	222/391
4,546,767	10/1985	Smith	604/224
4,801,008	1/1989	Rich	206/219

4,913,553	4/1990	Falco	366/129
4,994,065	2/1991	Gibbs et al.	604/209 X
5,005,735	4/1991	Keller	222/137
5,052,243	10/1991	Tepic	222/326 X
5,052,927	10/1991	Discko, Jr.	433/90
5,064,098	11/1991	Hutter, III et al.	222/137
5,080,493	1/1992	McKown et al.	366/177
5,125,836	6/1992	Dragan et al.	433/90
5,137,181	8/1992	Keller	222/134
5,165,890	11/1992	Discko, Jr.	433/90
5,236,108	8/1993	House	222/541
5,306,147	4/1994	Dragan et al.	433/90
5,336,014	8/1994	Keller	403/24
5,386,931	2/1995	Jacobsen et al.	222/327

FOREIGN PATENT DOCUMENTS

3903315	8/1989	Germany	604/82
62-43634	3/1987	Japan	.	

Primary Examiner—Louis S. Zarfes
Assistant Examiner—Eric Watterson
Attorney, Agent, or Firm—James D. Christoff

[57] **CLAIM**

The ornamental design for a cartridge dispenser, as shown and described.

DESCRIPTION

FIG. 1 is a top, rear and right side perspective view of a cartridge dispenser showing my new design; FIG. 2 is a right side elevational view thereof; FIG. 3 is a top plan view thereof; FIG. 4 is a bottom view thereof; FIG. 5 is a left side elevational view thereof; FIG. 6 is a front elevational view thereof; and, FIG. 7 is a rear elevational view thereof.

1 Claim, 3 Drawing Sheets

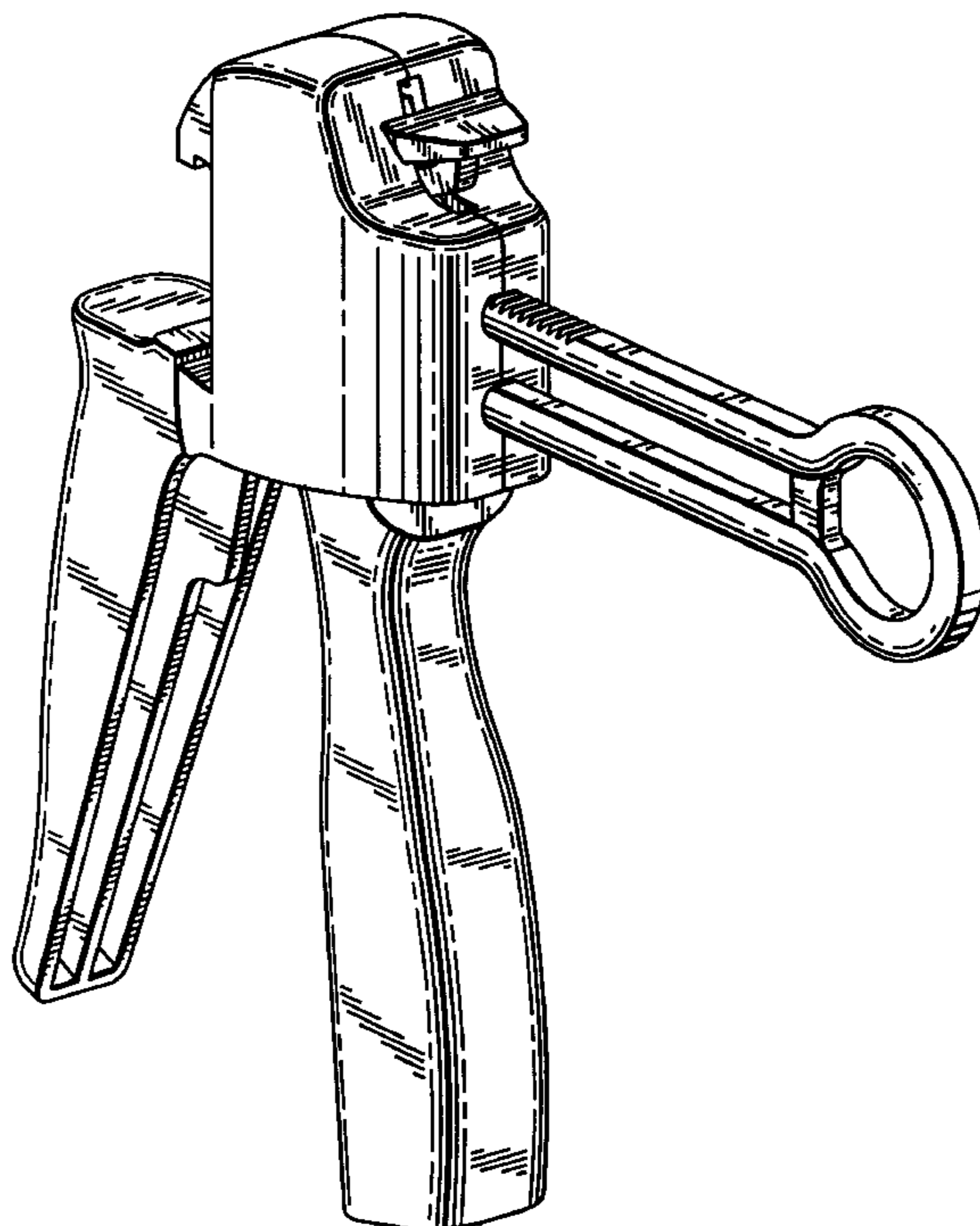

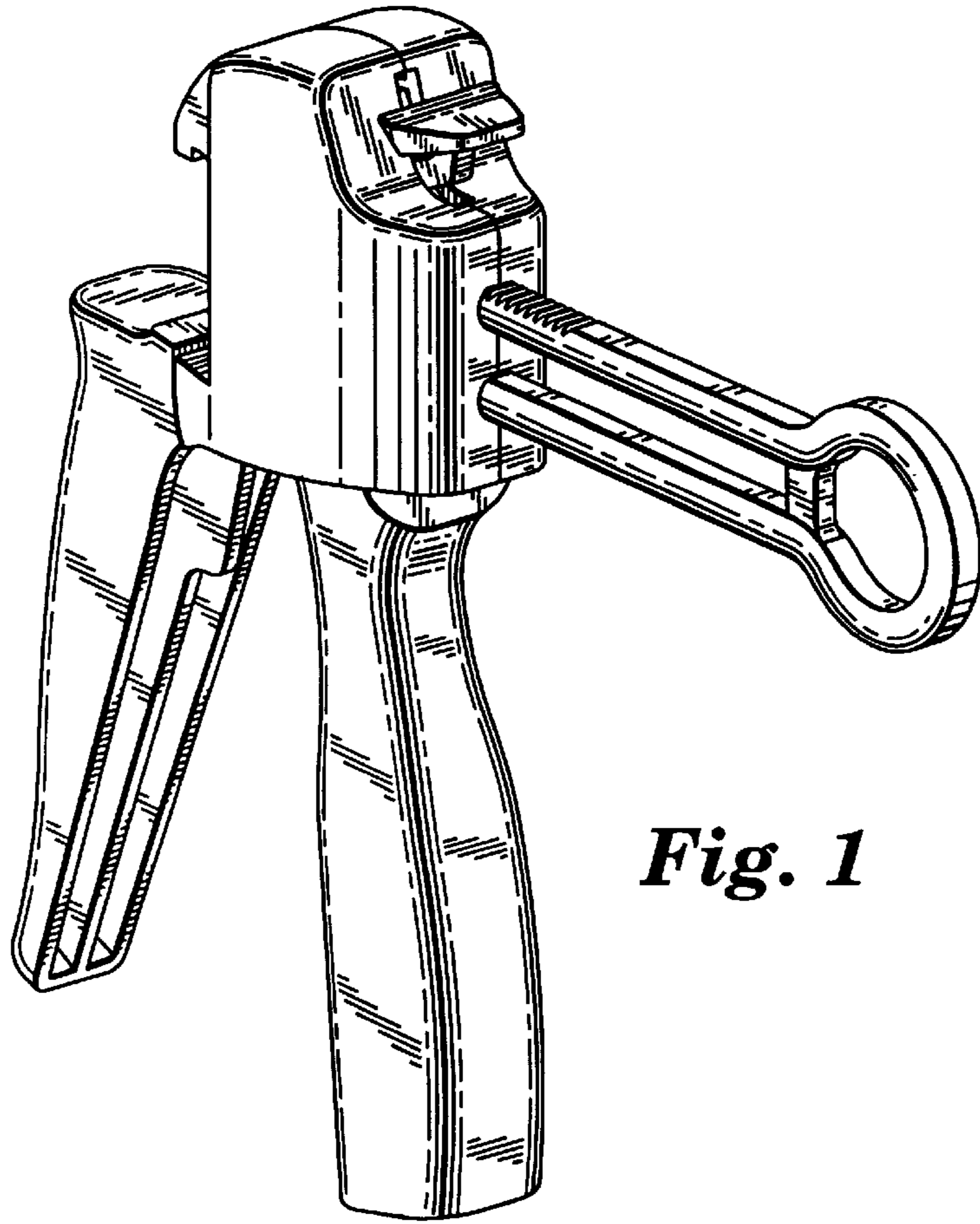

Fig. 1

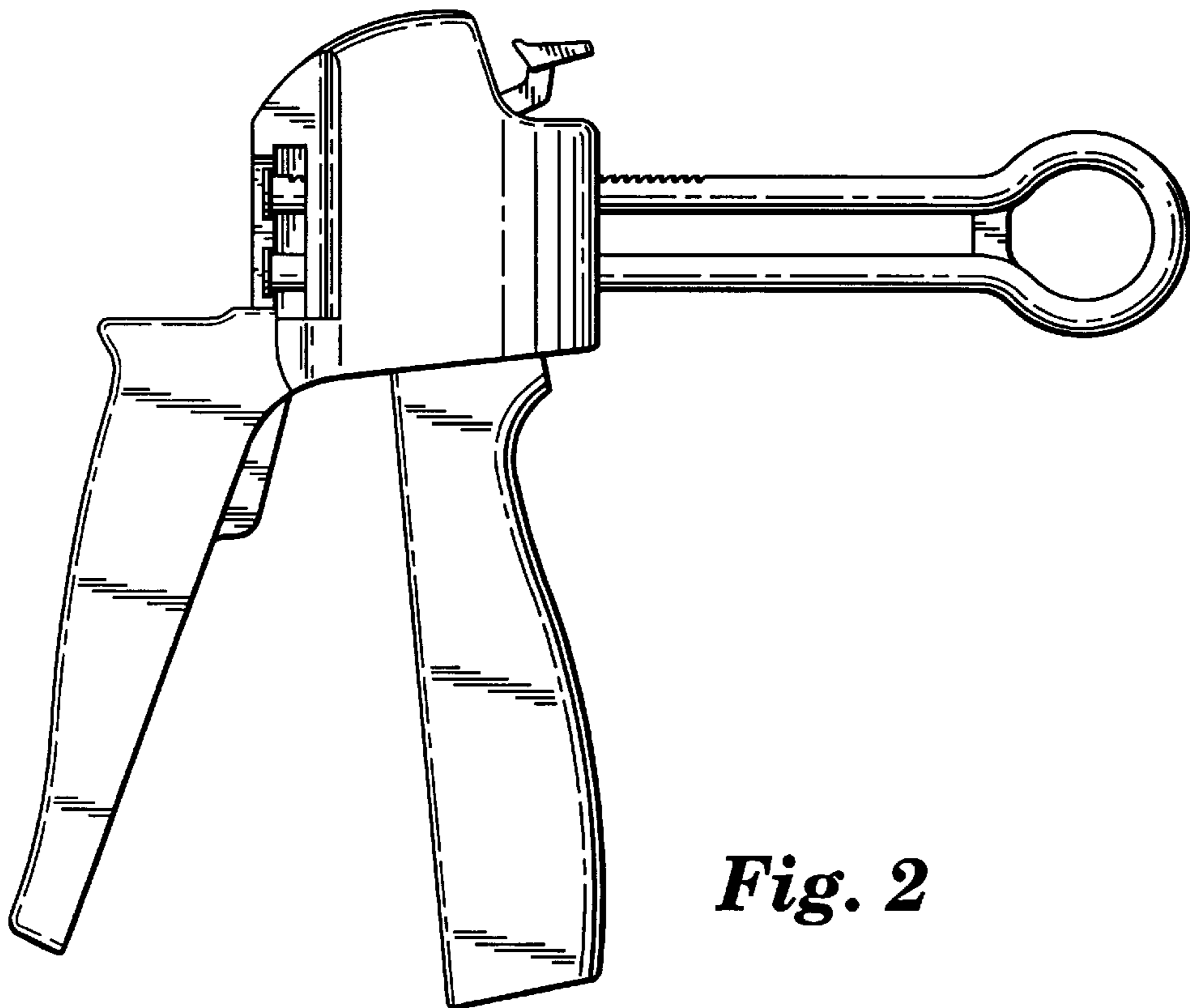

Fig. 2

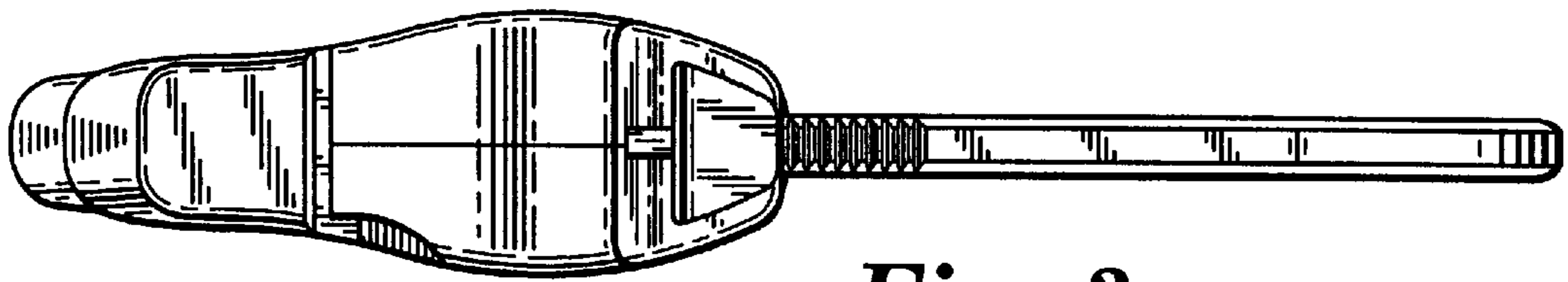

Fig. 3

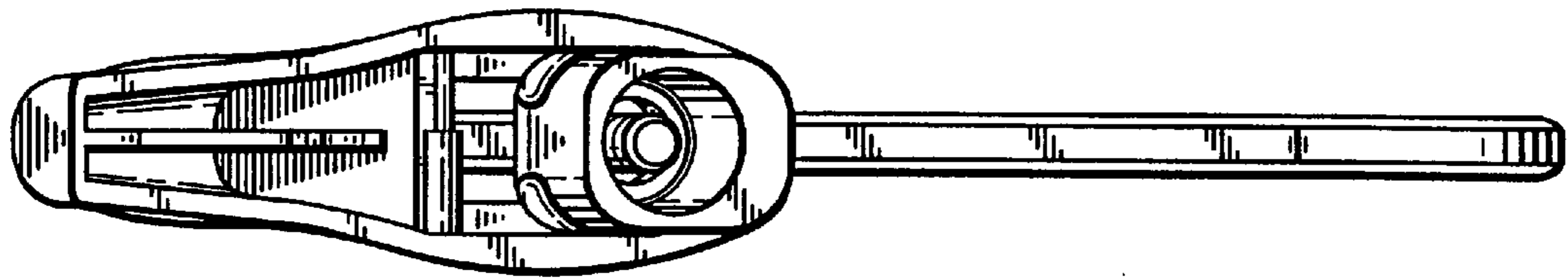

Fig. 4

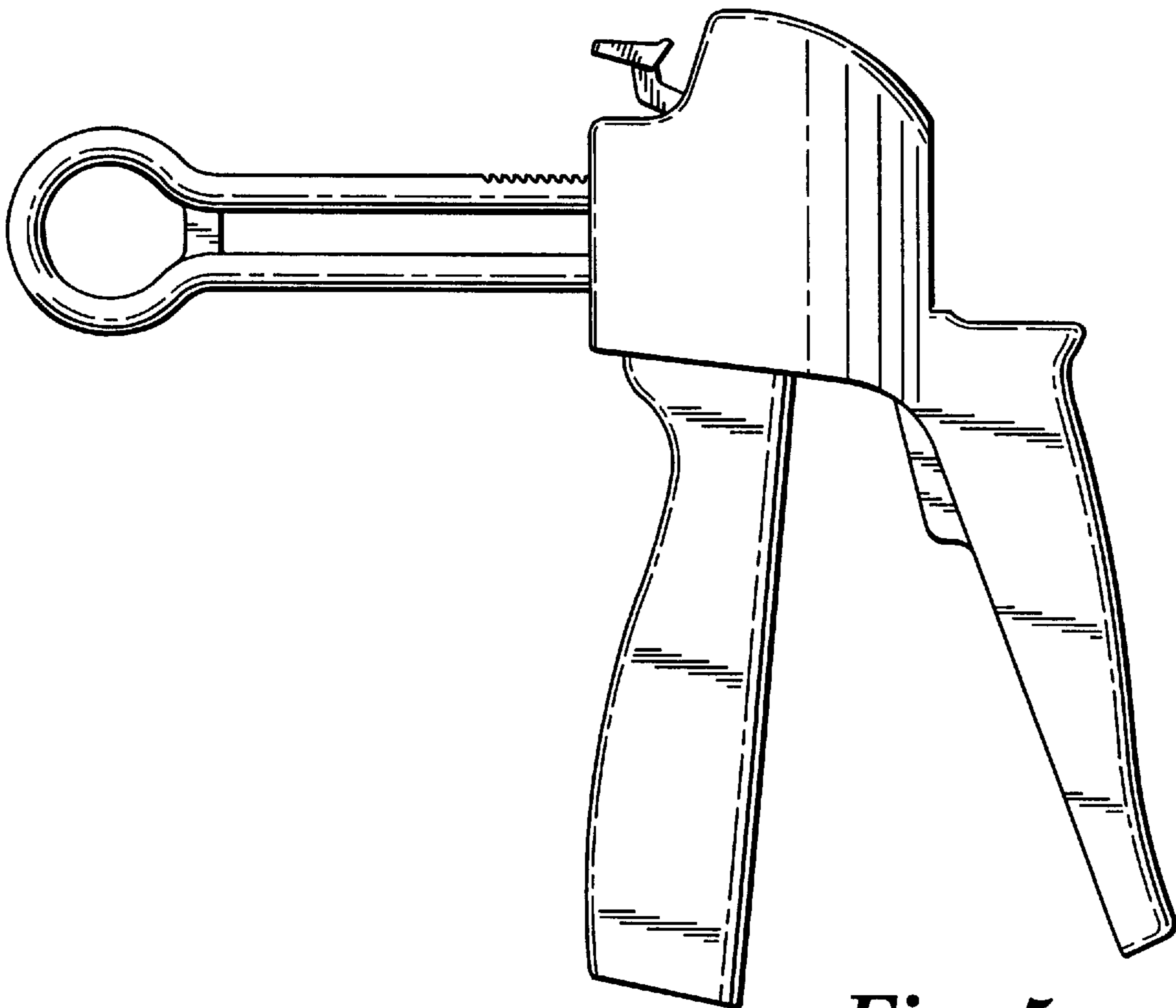

Fig. 5

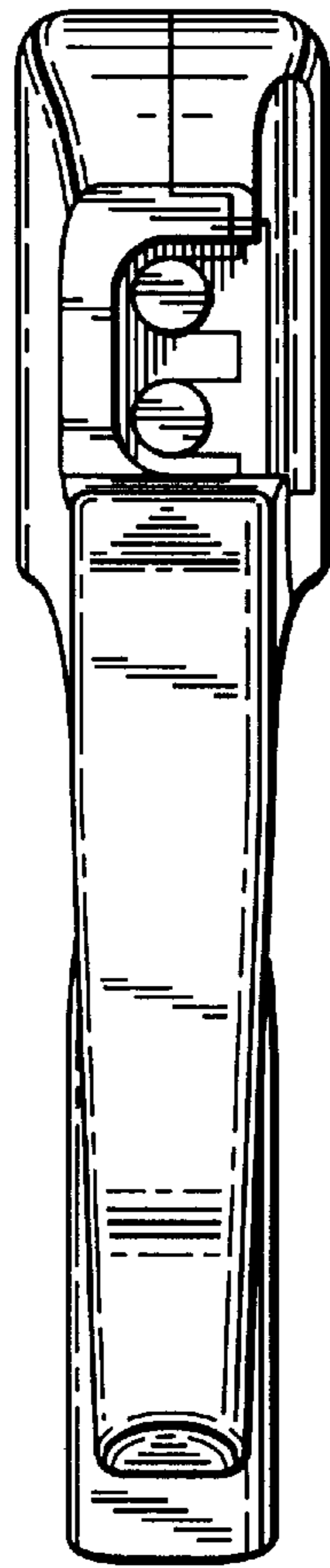

Fig. 6

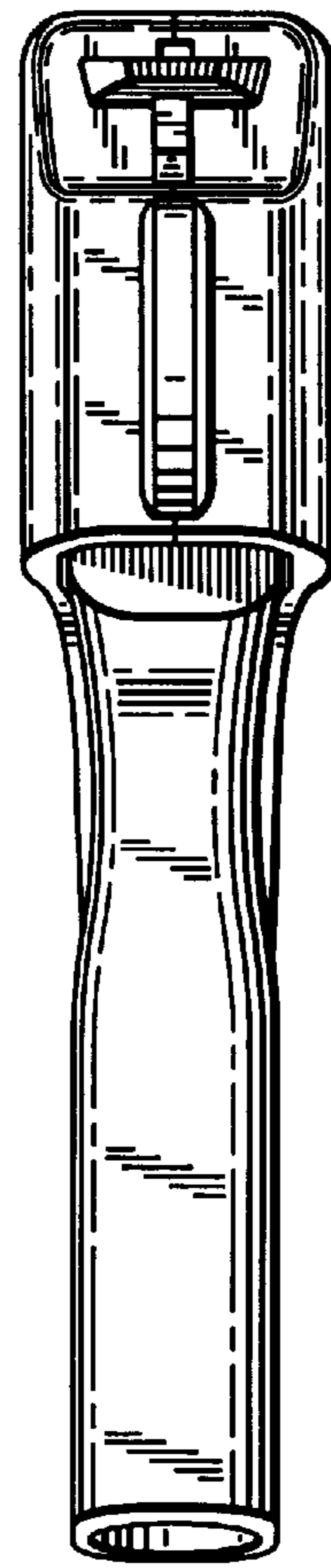

Fig. 7