



US00D398938S

United States Patent [19]

[11] **Patent Number: Des. 398,938**

Thurston et al.

[45] **Date of Patent: **Sep. 29, 1998**

[54] **HAND CONTROLLER FOR VIDEO GAME**

4,862,165 8/1989 Gart .
4,945,357 7/1990 Tal 463/38 X
5,389,950 2/1995 Bouton .

[76] Inventors: **Keith E. Thurston**, 4 Rhapsody Lane,
Ottawa, Ontario, Canada, K1V 1B1;
Kenneth G. Thurston, 2711, Pimlico
Crescent, Gloucester, Ontario, Canada,
K1T 2A7

FOREIGN PATENT DOCUMENTS

DES. 74486 7/1994 Canada .

[**] Term: **14 Years**

OTHER PUBLICATIONS

HongKong Enterprise, p. 813, Oct. 1990.
Playthings, p. 50, Sep. 1981.

[21] Appl. No.: **68,337**

Primary Examiner—Prabhakar G. Deshmukh

[22] Filed: **Apr. 3, 1997**

[51] **LOC (6) Cl.** **21-01**

[57] CLAIM

[52] **U.S. Cl.** **D21/48**

The ornamental design for a hand controller for video game,
as shown and described.

[58] **Field of Search** D21/1, 13, 48;
D14/114, 124, 217, 100; 273/148 B; 463/1,
30-35, 37-47

DESCRIPTION

[56] References Cited

U.S. PATENT DOCUMENTS

D. 272,835	2/1984	Lichac	D21/48
D. 317,947	7/1991	Tal	D21/48
D. 330,230	10/1992	Carter	.	
D. 334,415	3/1993	Carter et al.	D21/48
D. 372,470	8/1996	Hsien	D14/114
D. 379,203	5/1997	Oikawa	D21/48
4,445,011	4/1984	Hansen	463/38 X
4,479,038	10/1984	Marhold et al.	463/38 X
4,552,360	11/1985	Bromley et al.	463/31 X

FIG. 1 is a perspective view of hand controller for video game showing our new design;
FIG. 2 is a front elevational view thereof;
FIG. 3 is a rear elevational view thereof;
FIG. 4 is a left top perspective view thereof;
FIG. 5 is a right top perspective view thereof; and,
FIG. 6 is a top plan view thereof.
FIGS. 2-5 are drawn in an enlarged scale and show only the upper shaft of the controller for clarity. The bottom is unornamented.

1 Claim, 6 Drawing Sheets

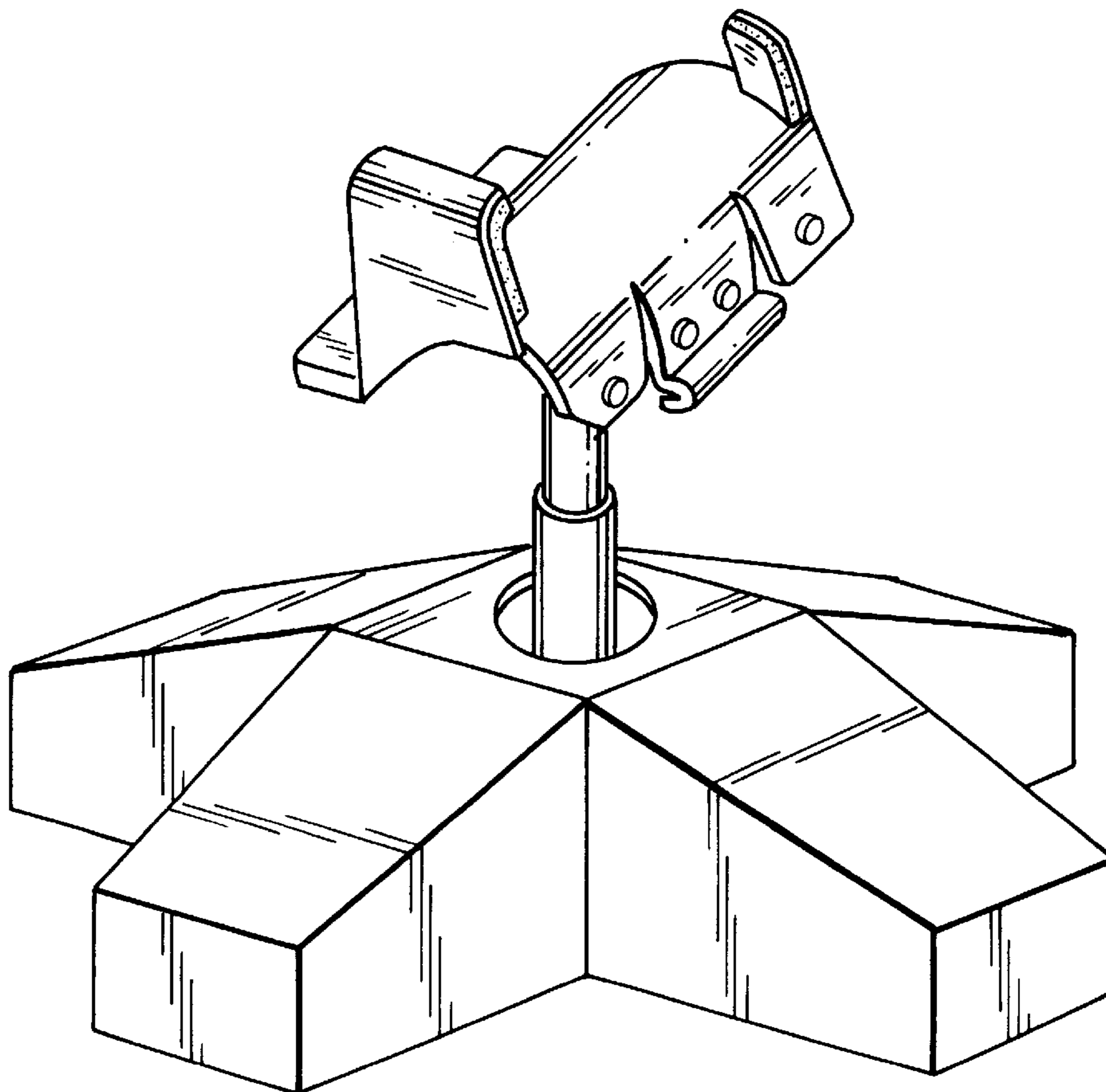

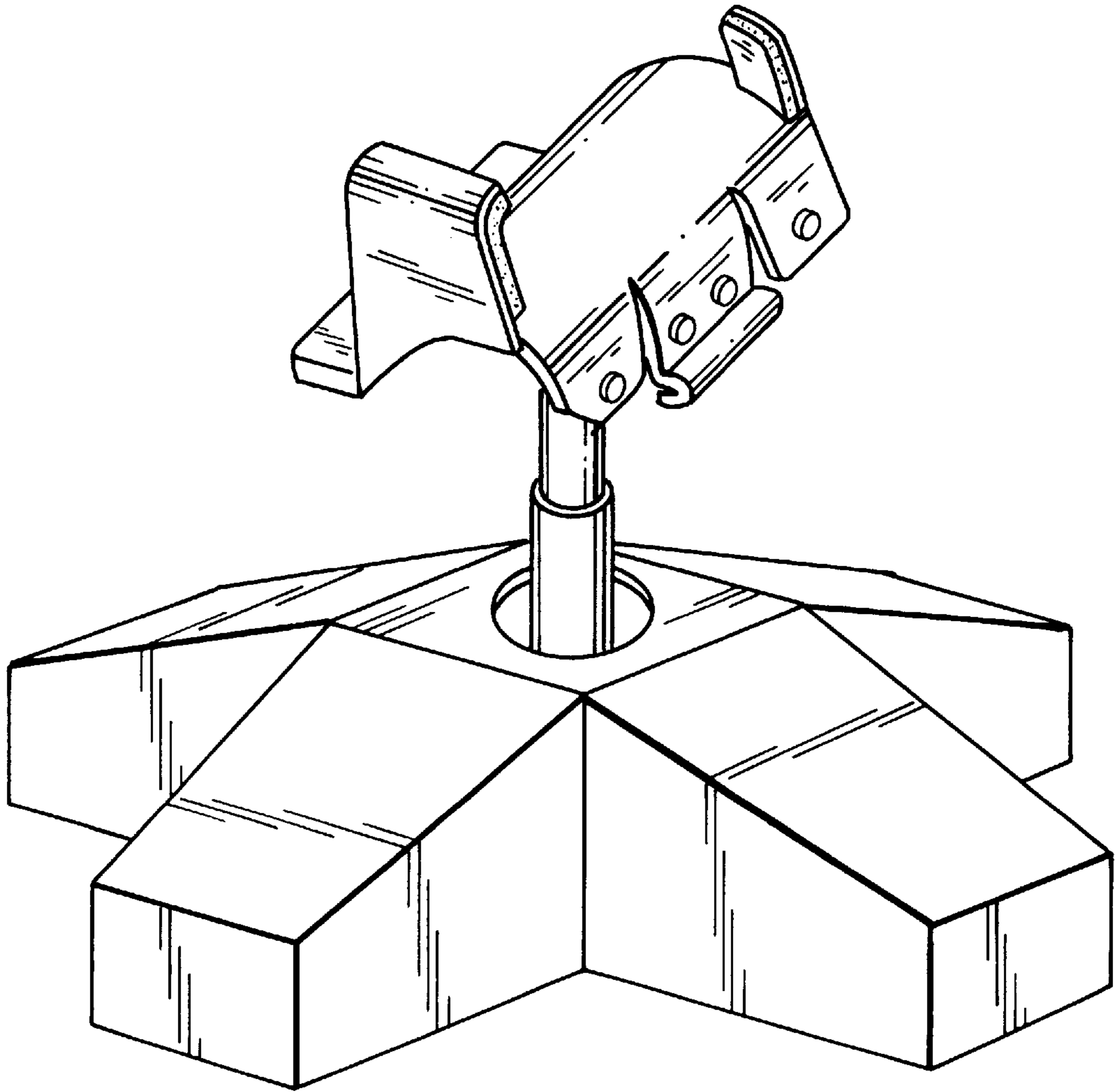

FIG. 1

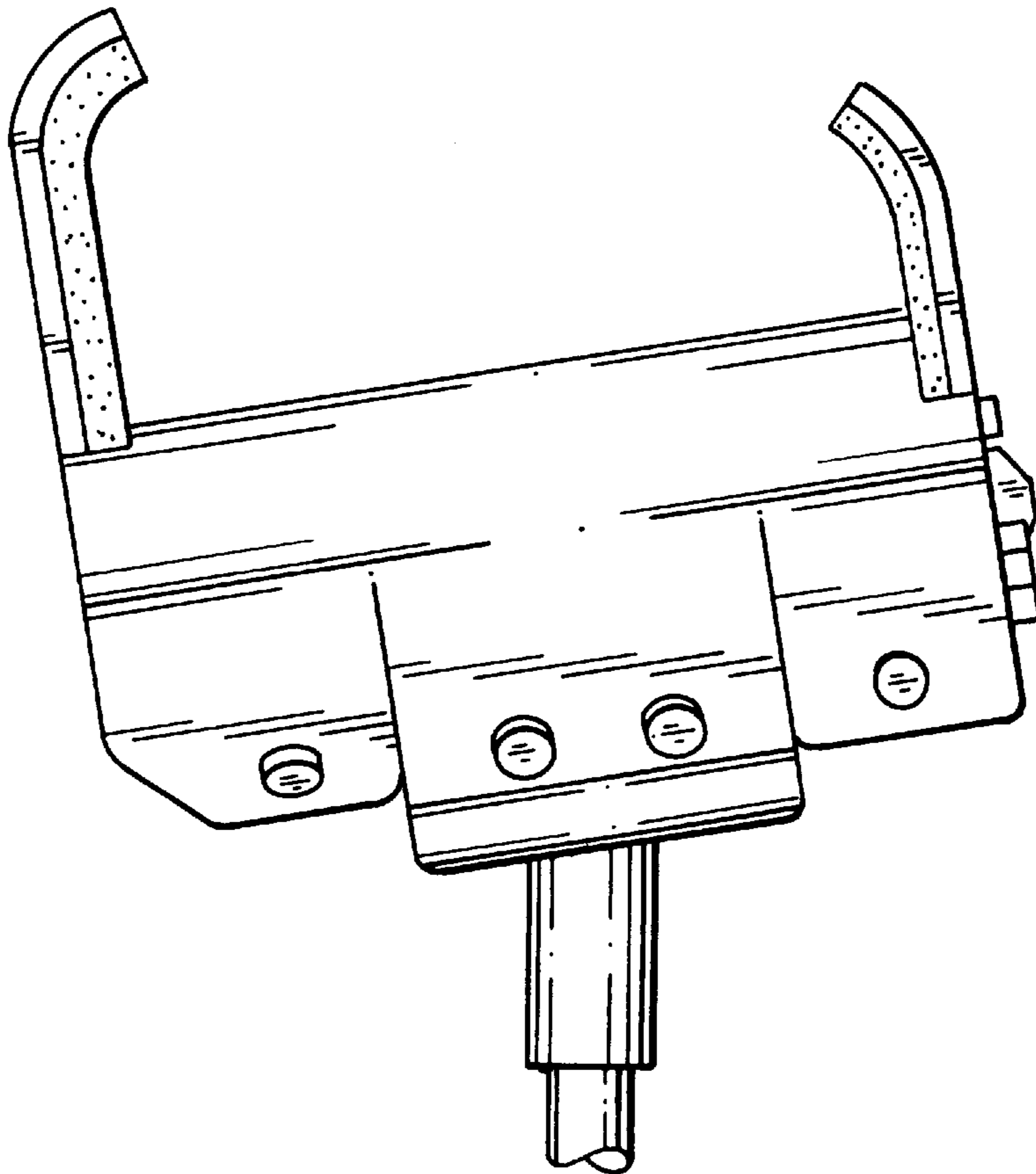

FIG. 2

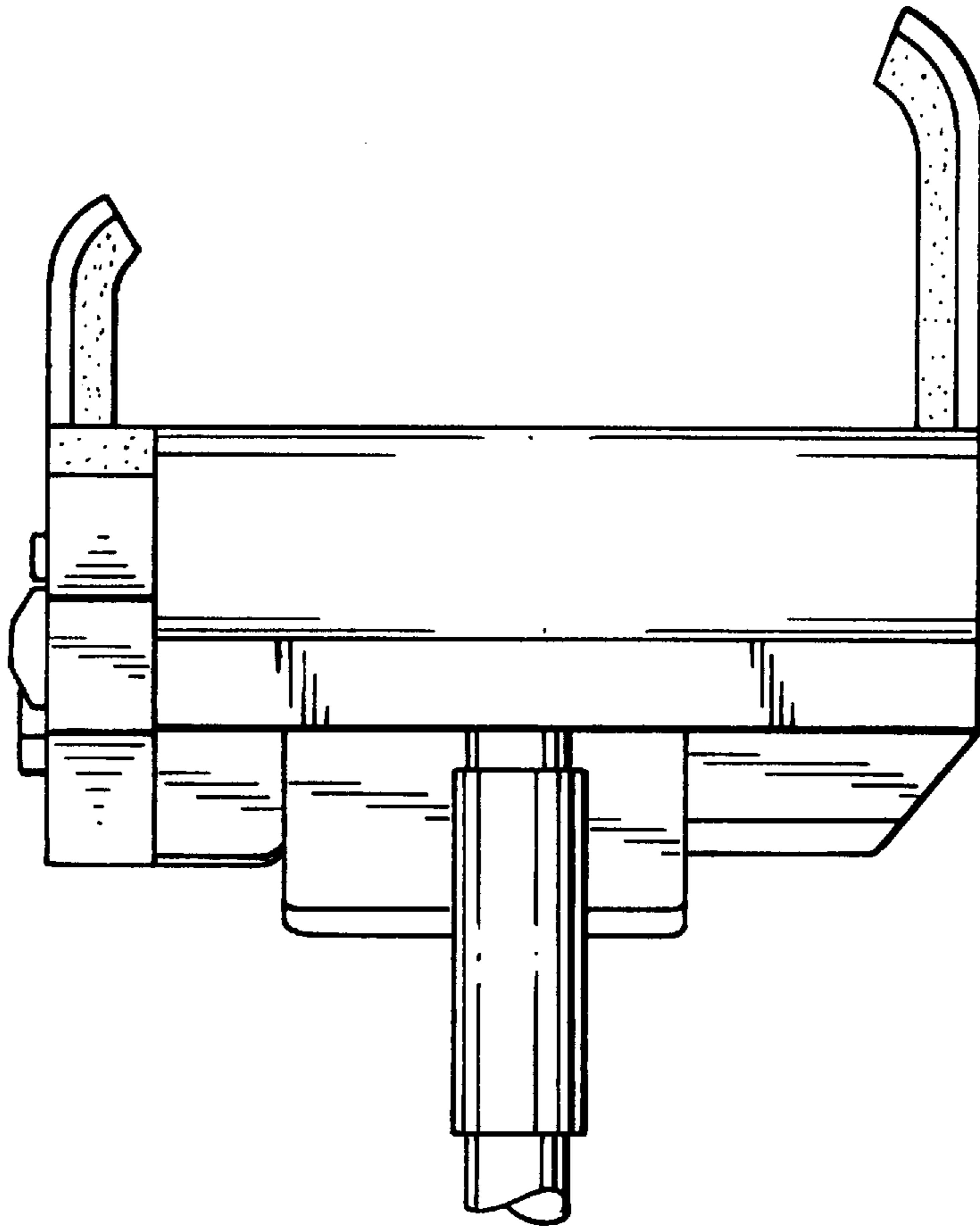

FIG. 3

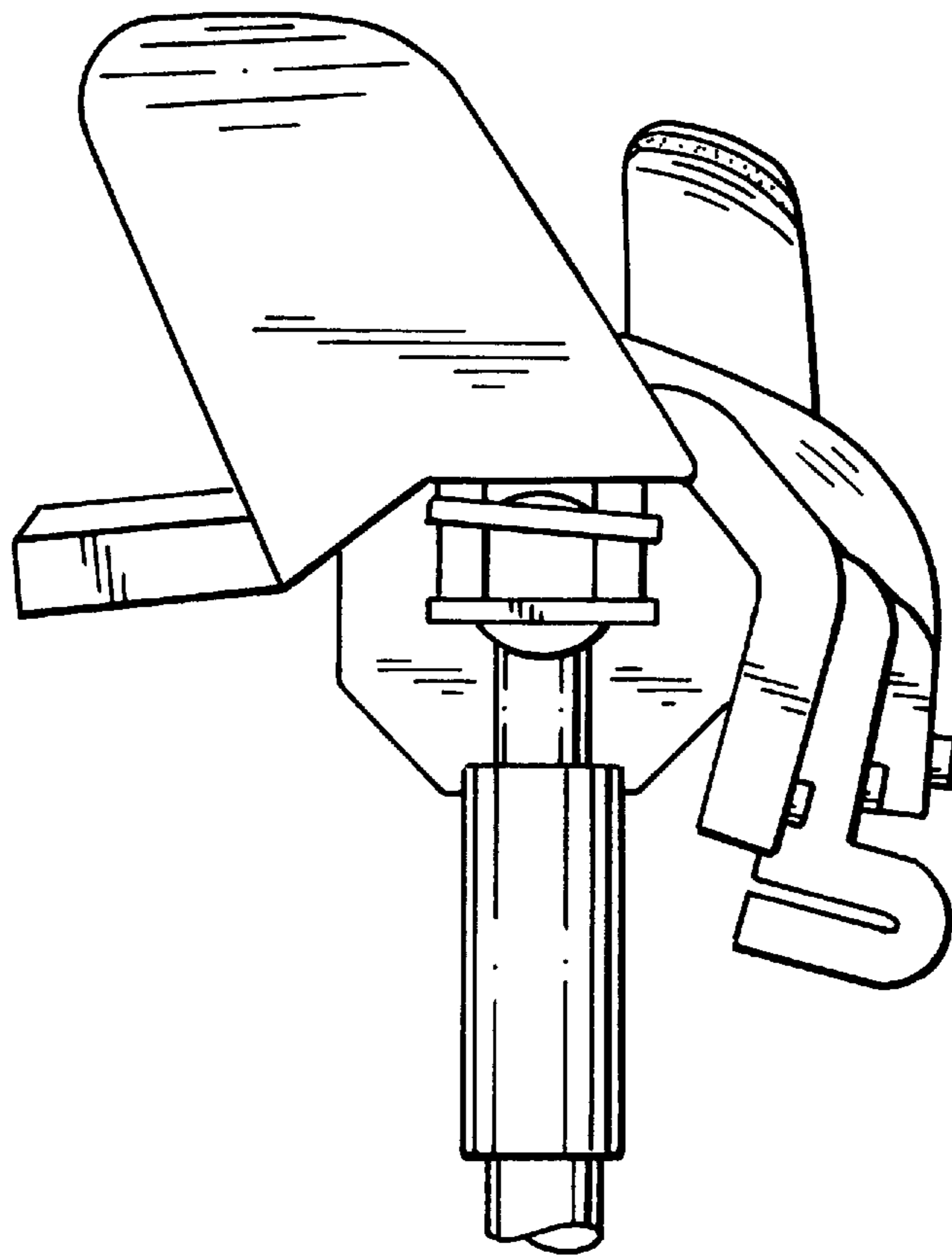

FIG. 4

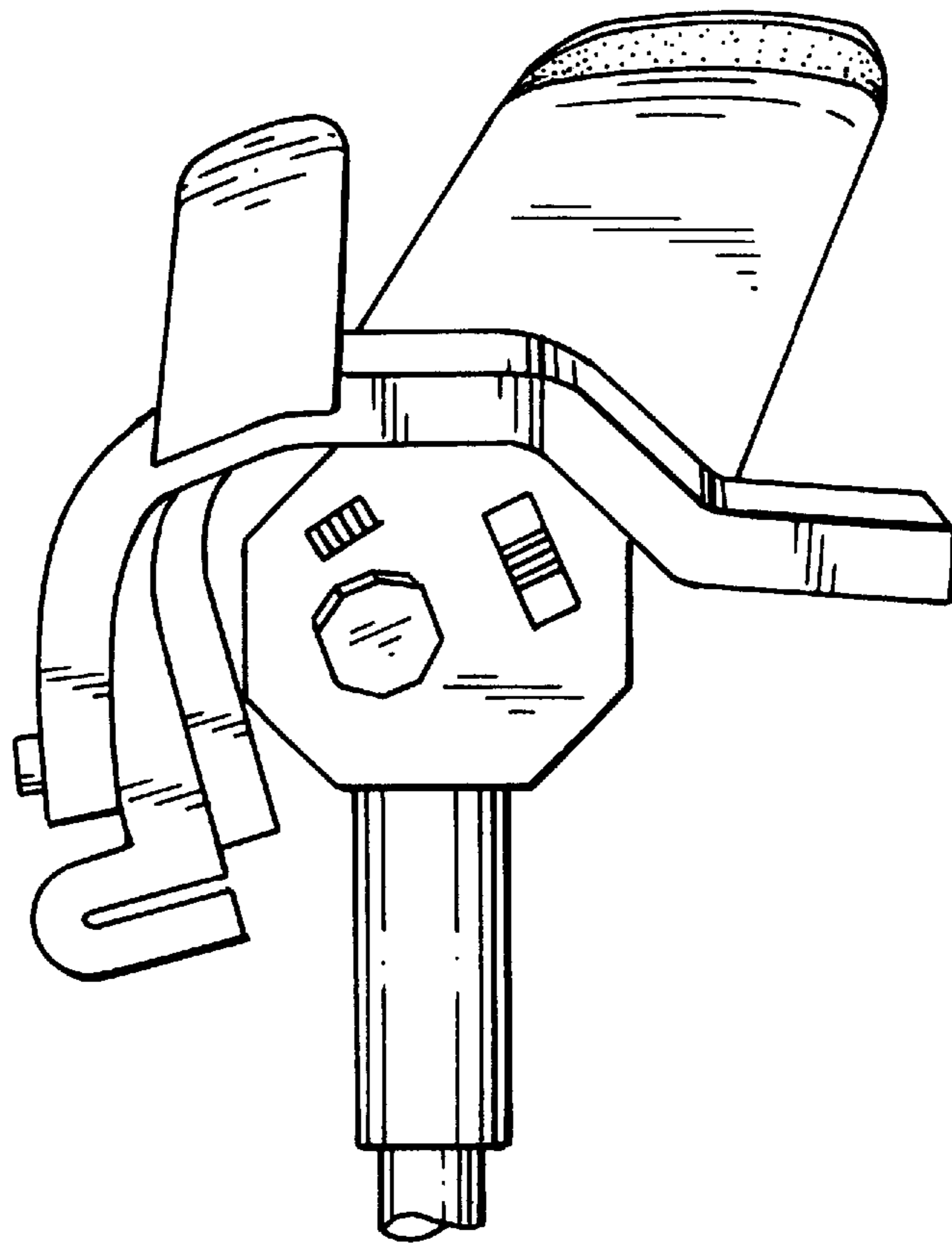

FIG. 5

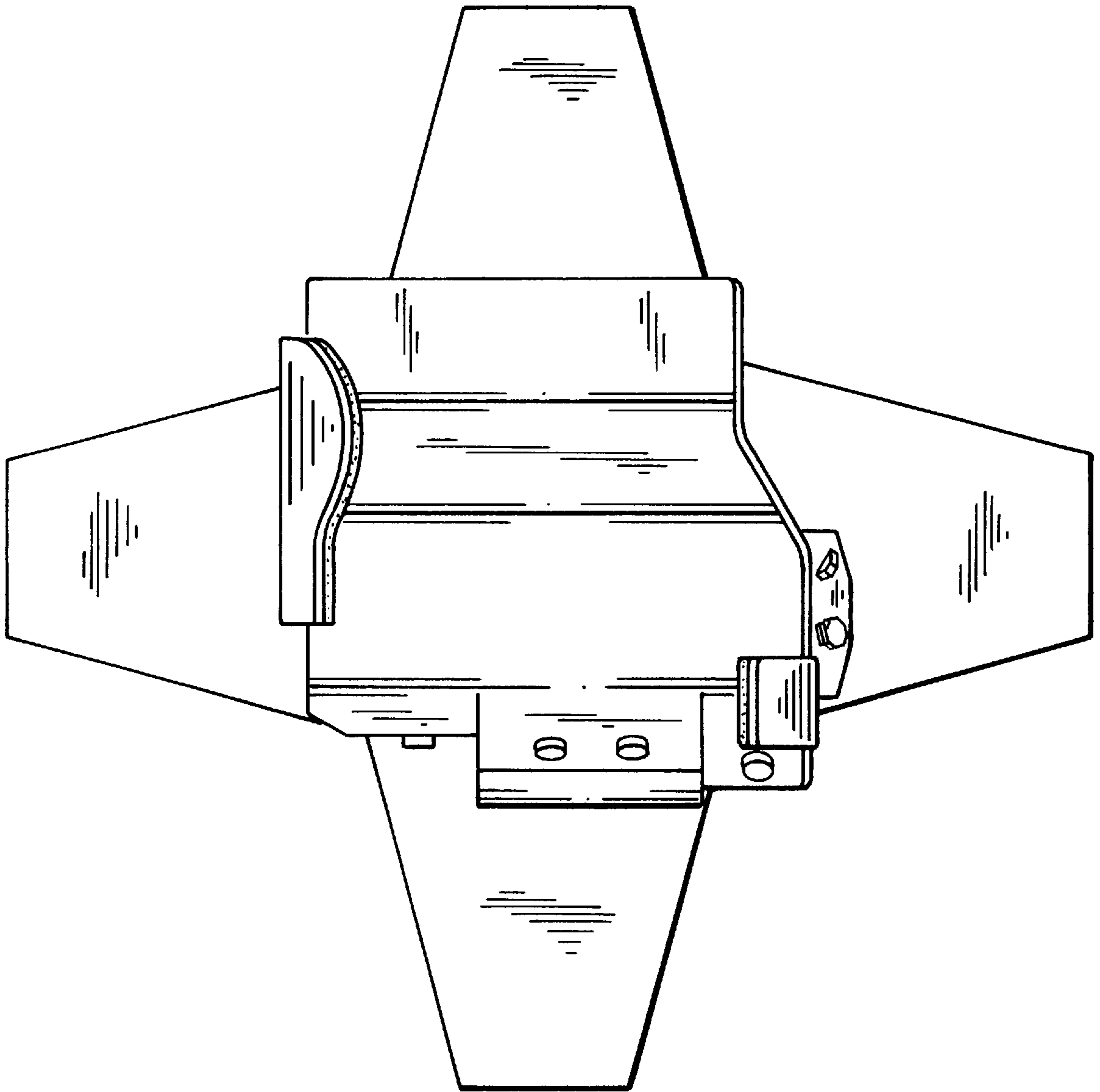

FIG. 6