



US00D398883S

# United States Patent [19]

Davidson et al.

[11] **Patent Number: Des. 398,883**

[45] **Date of Patent: \*\*Sep. 29, 1998**

[54] **FENDERTIP TRIM**

[75] Inventors: **William G. Davidson**, Delafield;  
**Raymond W. Drea**, Whitefish Bay,  
both of Wis.

[73] Assignee: **Harley-Davidson Motor Company**,  
Milwaukee, Wis.

[\*\*] Term: **14 Years**

[21] Appl. No.: **73,437**

[22] Filed: **Jul. 9, 1997**

[51] **LOC (6) Cl.** ..... **12-11**

[52] **U.S. Cl.** ..... **D12/114**

[58] **Field of Search** ..... D12/114, 110,  
D12/197, 199; 280/288.4

[56] **References Cited**

### PUBLICATIONS

Harley Davidson Genuine Parts & Accessories, p. 73 The Dresser V-Logo Front & Rear Fender Rails. ©1995.  
Drag Specialties Catalog, p. 8, The Fender Light Lens Grill (DS-719977. ©1995.  
Harley-Davidson 1994 V-Twin Manufacturing, pp. 257 and 260.

1994 Harley-Davidson Genuine Parts & Accessories, p. 47.  
Harley-Davidson 1994 Custom Chrome Catalog, pp. 233, 625, 626 and 627.

1995 Harley-Davidson Genuine Parts & Accessories, p. 154.

*Primary Examiner*—Melody N. Brown  
*Attorney, Agent, or Firm*—Michael, Best & Friedrich LLP

[57] **CLAIM**

We claim the ornamental design for a fendertip trim, as shown and described.

### DESCRIPTION

FIG. 1 is a perspective view of a fendertip trim showing our new design;

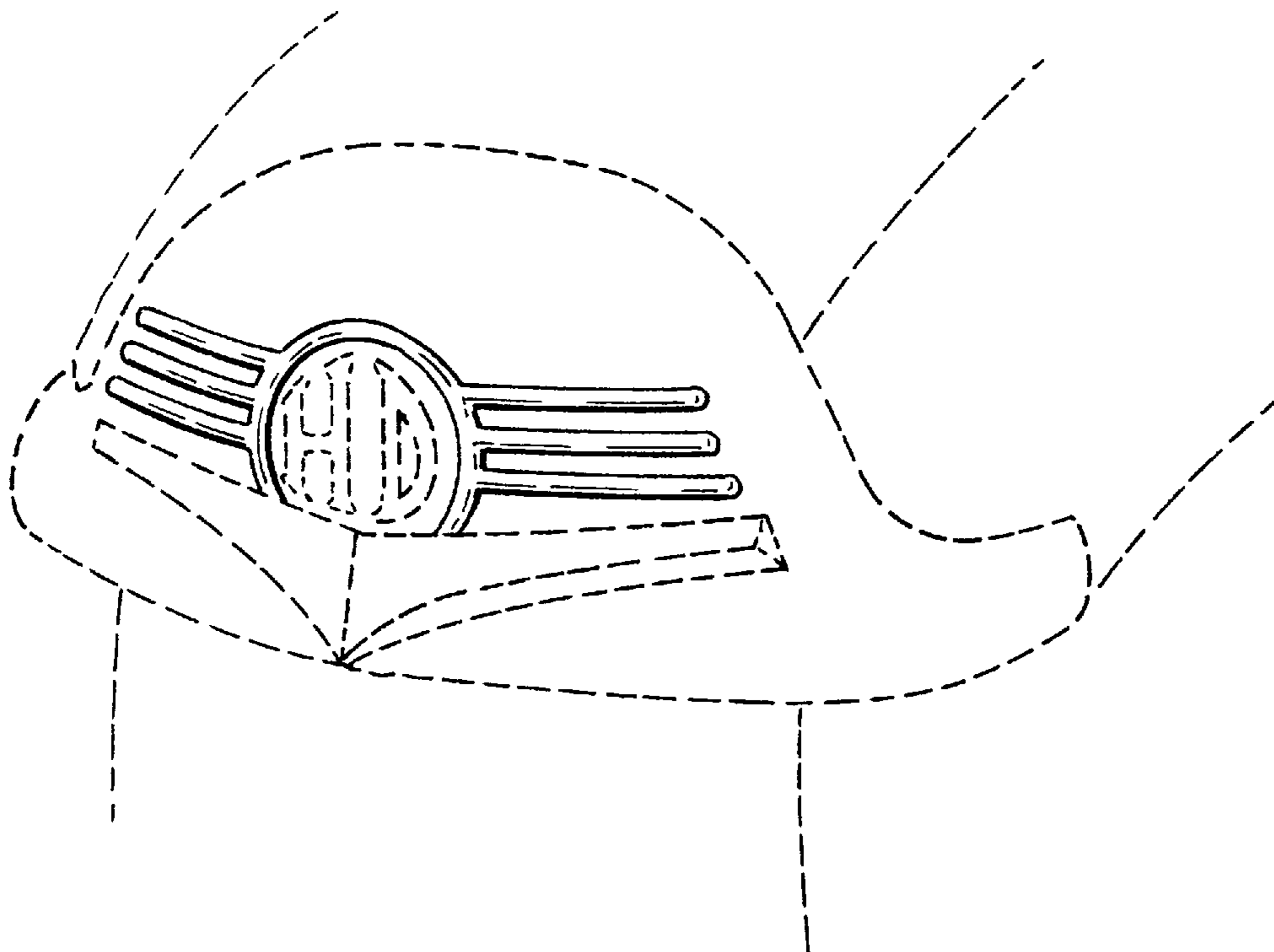
FIG. 2 is a front view of the fendertip trim of FIG. 1;

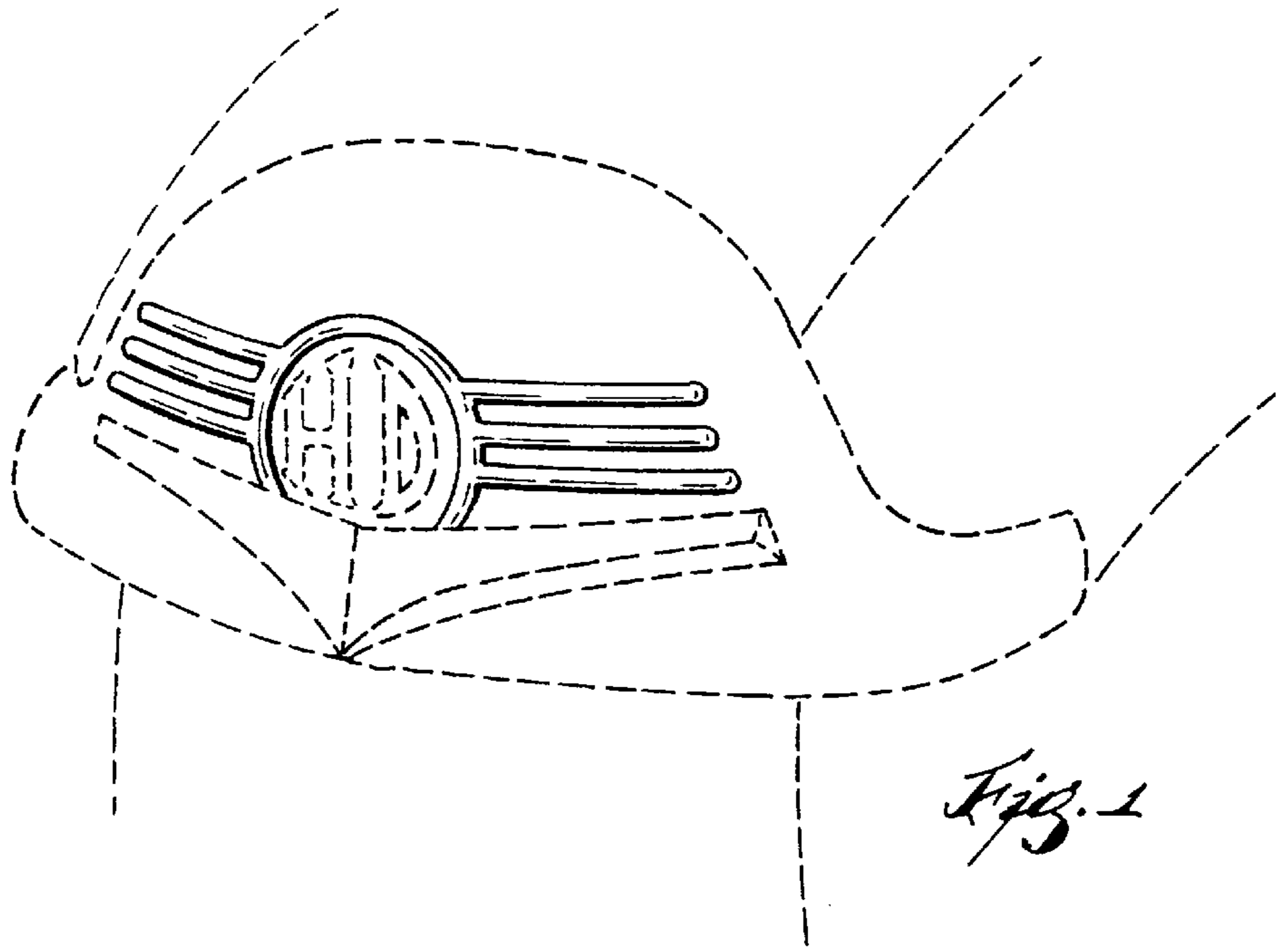
FIG. 3 is a top perspective view of the fendertip trim of FIG. 1; and,

FIG. 4 is a left side view of the fendertip trim of FIG. 1 the right side being a mirror image of that shown.

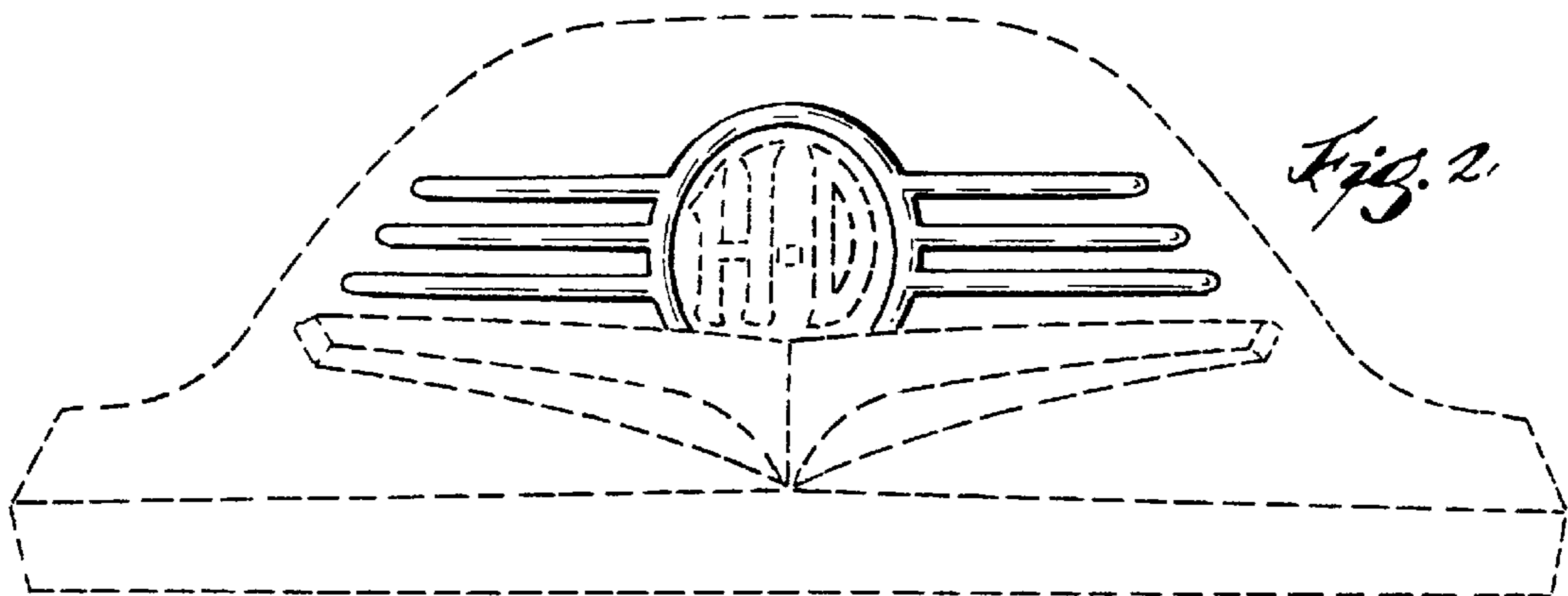
The motorcycle fender in broken lines in all drawing views are for illustrative purposes only and form no part of the claimed design. The bottom and rear of the fendertip trim are not visible in its normal and intended use because they are substantially obscured by the motorcycle fender.

**1 Claim, 2 Drawing Sheets**

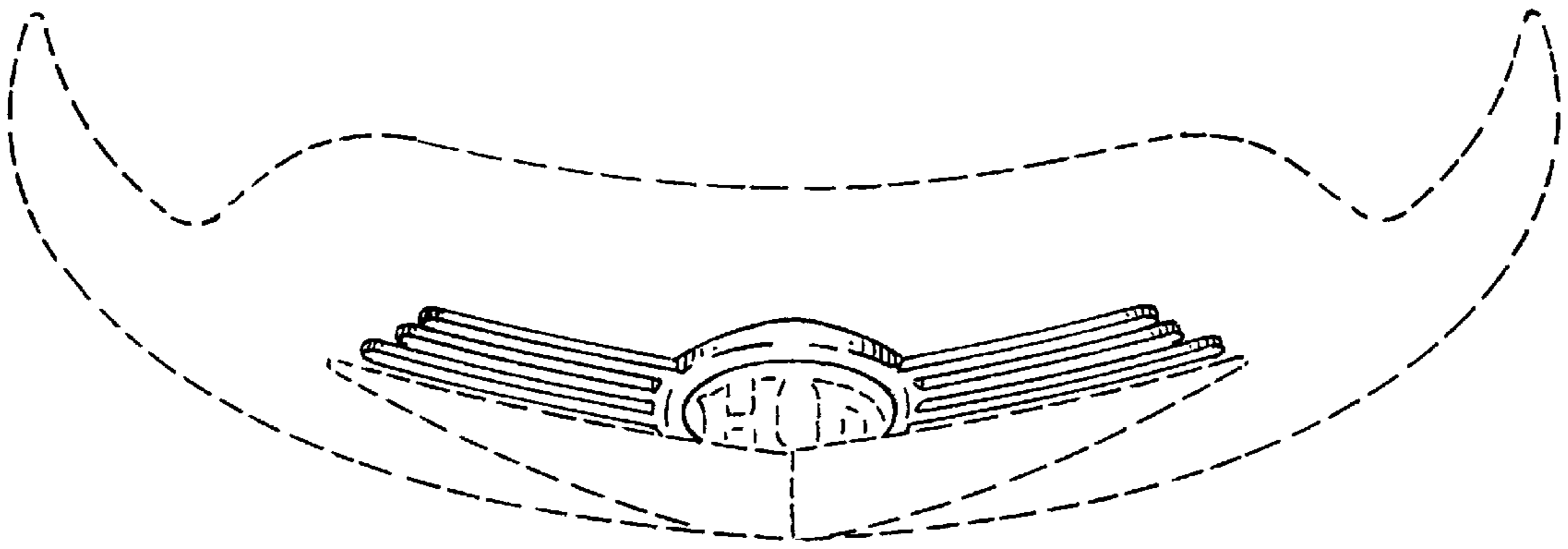




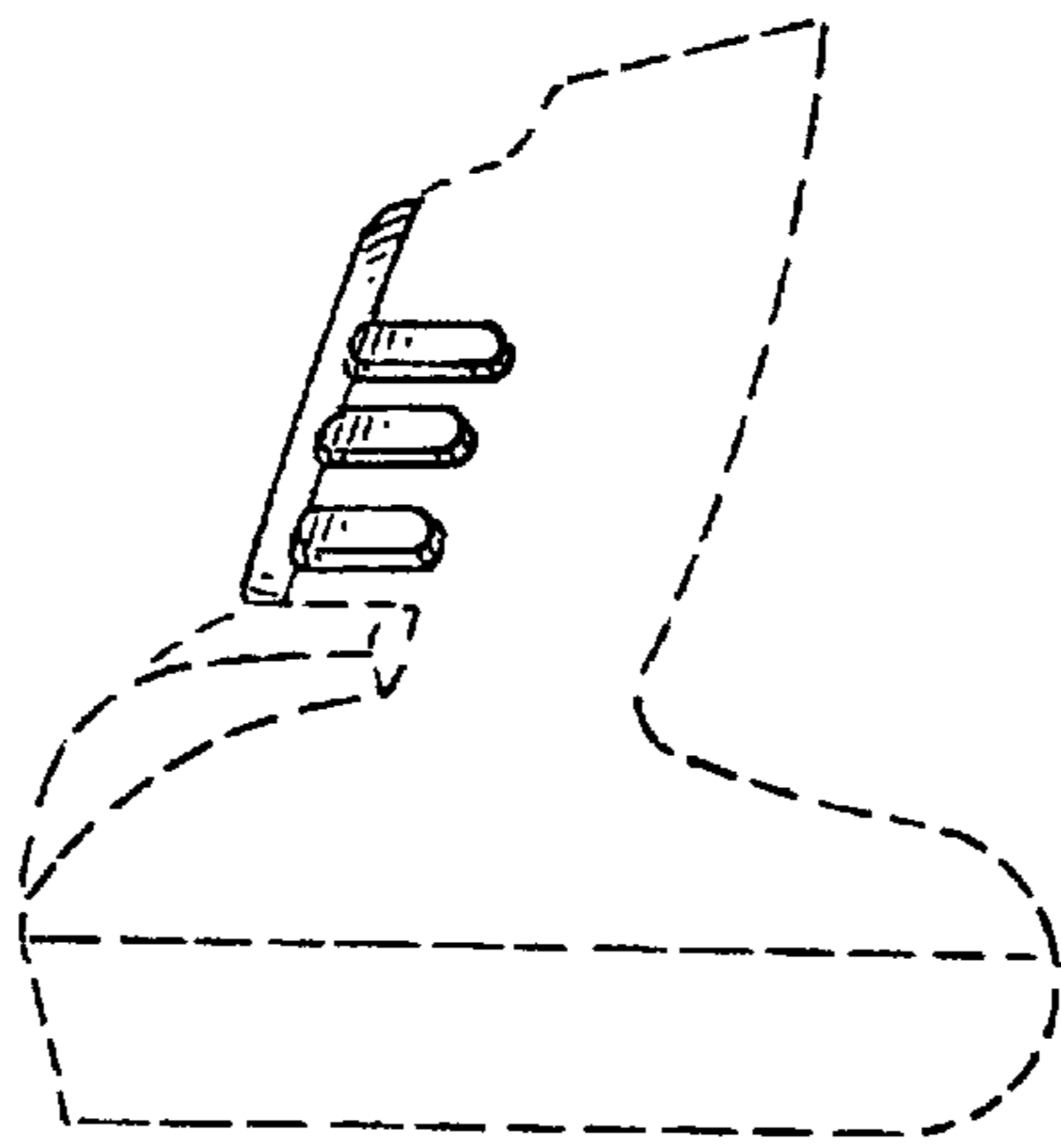
*Fig. 1*



*Fig. 2*



*Fig. 3*



*Fig. 4*