



US00D398284S

# United States Patent [19]

[11] **Patent Number: Des. 398,284**

**Carter et al.**

[45] **Date of Patent: \*\*Sep. 15, 1998**

[54] **SET OF UTILITY RACKS FOR TRUCK BEDS**

[76] Inventors: **Randy A. Carter**, 15449 N. 25th Ave., #2076, Phoenix, Ariz. 85023; **Flake Thomas Carter**, 37640 N. 14th St., Phoenix, Ariz. 85027

[\*\*] Term: **14 Years**

[21] Appl. No.: **70,269**

[22] Filed: **May 5, 1997**

[51] **LOC (6) Cl. .... 12-16**

[52] **U.S. Cl. .... D12/406**

[58] **Field of Search** ..... D12/400, 406, D12/412-414; 296/37.1, 3

[56] **References Cited**

**U.S. PATENT DOCUMENTS**

D. 363,460	10/1995	Marshall	.....	D12/406
4,770,458	9/1988	Burke et al.	.	
5,002,324	3/1991	Griffin	.	
5,037,152	8/1991	Hendricks	.....	296/3
5,137,320	8/1992	Christensen	.....	296/3
5,143,415	9/1992	Boudah	.....	296/3
5,192,107	3/1993	Smith, Sr.	.	
5,238,280	8/1993	Christensen	.....	296/3
5,303,858	4/1994	Price	.	
5,431,472	7/1995	Coffland	.....	296/3
5,454,612	10/1995	Christensen	.	
5,494,327	2/1996	Derektor	.....	296/3
5,513,890	5/1996	Christensen	.....	296/3
5,520,316	5/1996	Chen	.....	296/3 X
5,560,666	10/1996	Vieira et al.	.....	296/3

*Primary Examiner*—Jeffrey Asch  
*Assistant Examiner*—Stacia Sinuik  
*Attorney, Agent, or Firm*—Snell & Wilmer, L.L.P.

[57] **CLAIM**

The ornamental design for the “set of utility racks for truck beds”, as shown and described.

**DESCRIPTION**

FIG. 1 is a perspective view of the set of utility racks for truck beds showing my new design where the racks are shown in position and secured to the bed of a pick-up truck. The broken line showing of the pickup truck is for illustrative purposes only and forms no part of the claimed design; FIG. 2 is an enlarged front elevational view of one of the racks of the set of utility racks for truck beds; FIG. 3 is a side elevational view of FIG. 2; FIG. 4 is a top plan view of FIG. 2; FIG. 5 is a section view of a single rack member of the set of utility racks for truck beds taken along line 5—5 of FIG. 2; FIG. 6 is a bottom plan view of FIG. 2; FIG. 7 is a perspective view of the set of utility racks for truck beds showing the set of racks secured at opposite ends along the length of the bed of a pickup truck. The broken line showing of the pickup truck is for illustrative purposes only and forms no part of the claimed design; and, FIG. 8 is a perspective view of set of utility racks for truck beds showing the set of racks positioned adjacent one another at the front end of the pickup truck. The broken line showing of the pickup truck is for illustrative purposes only and forms no part of the claimed design.

**1 Claim, 2 Drawing Sheets**

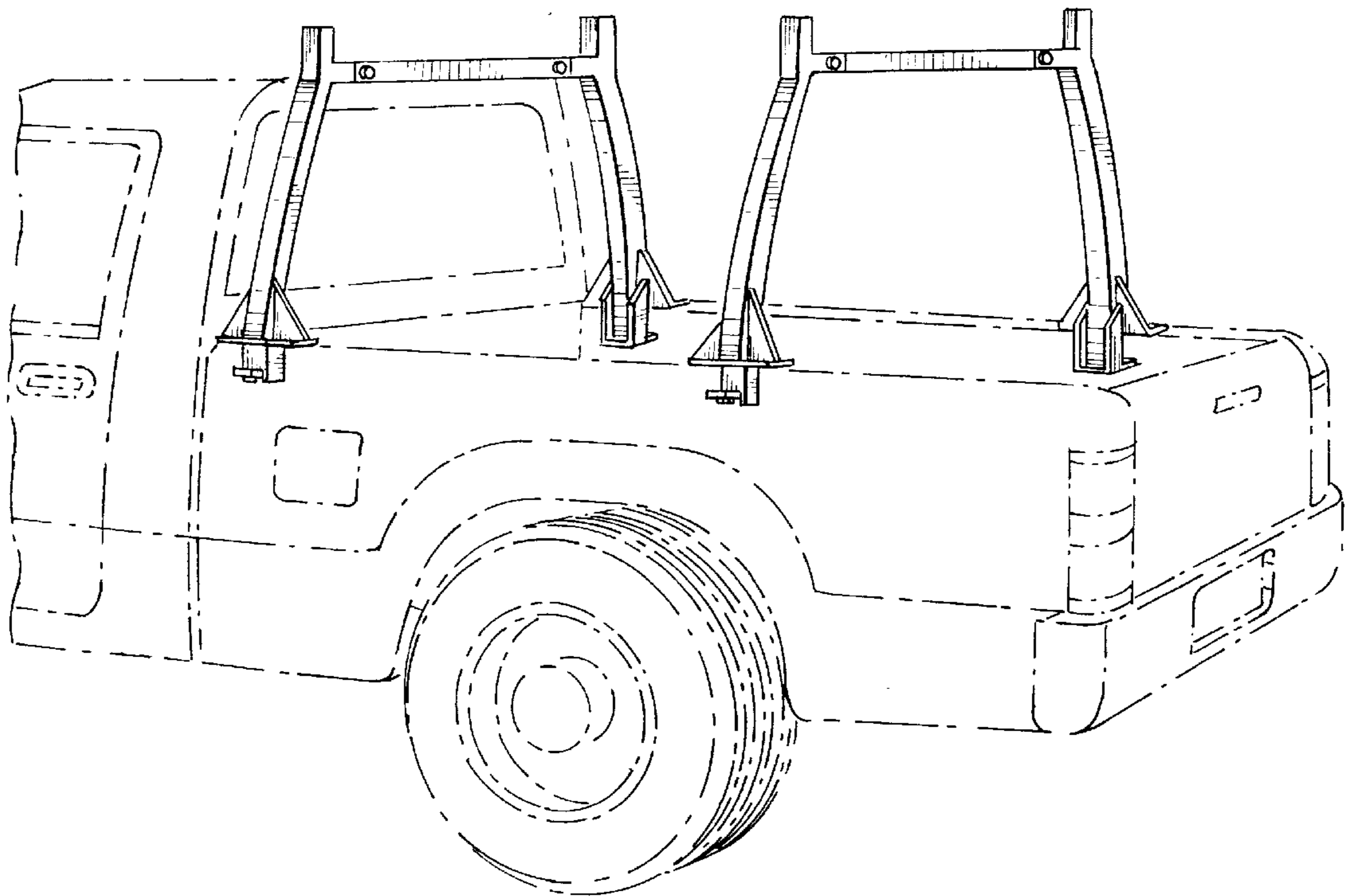

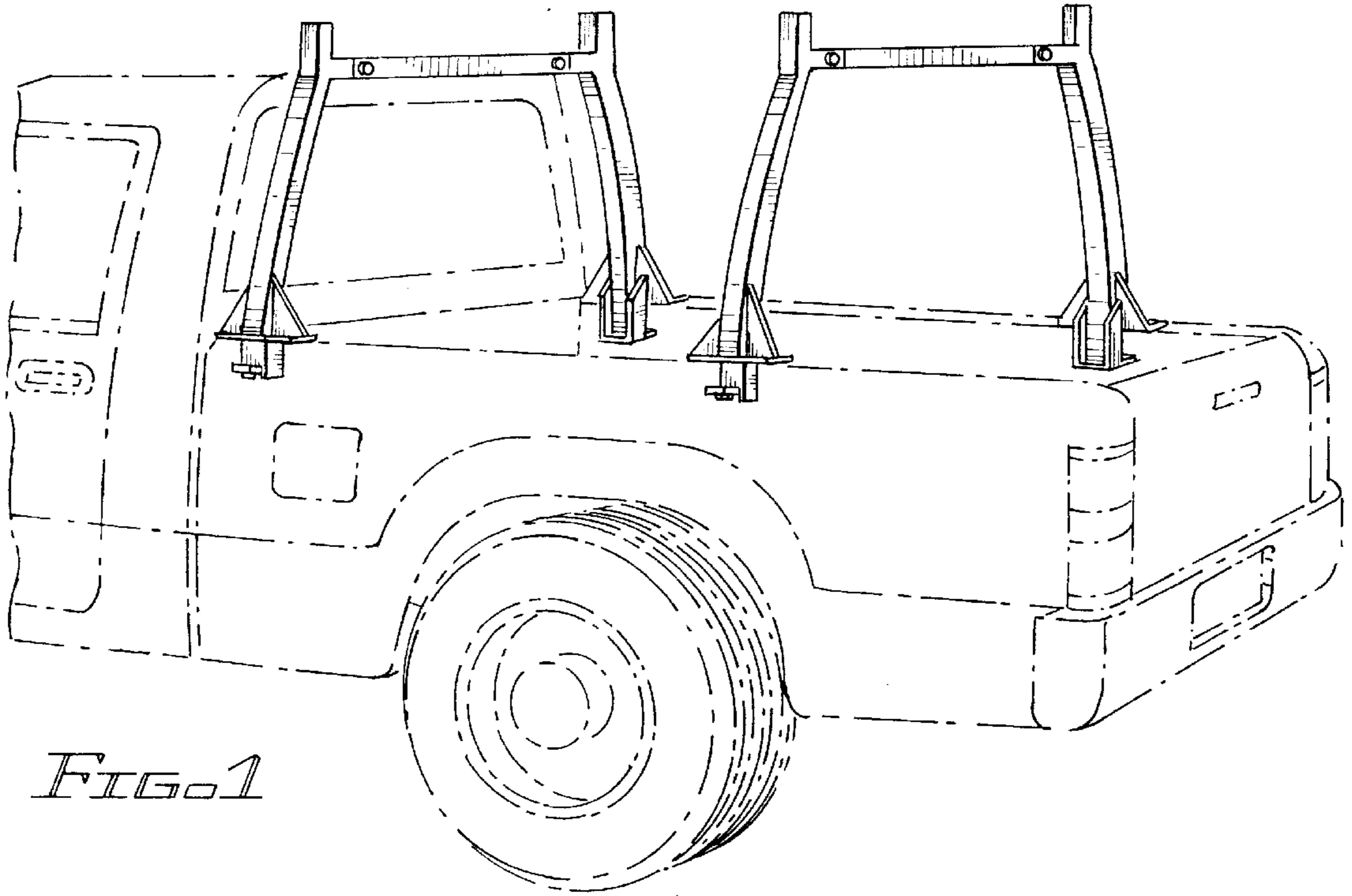

FIG. 1

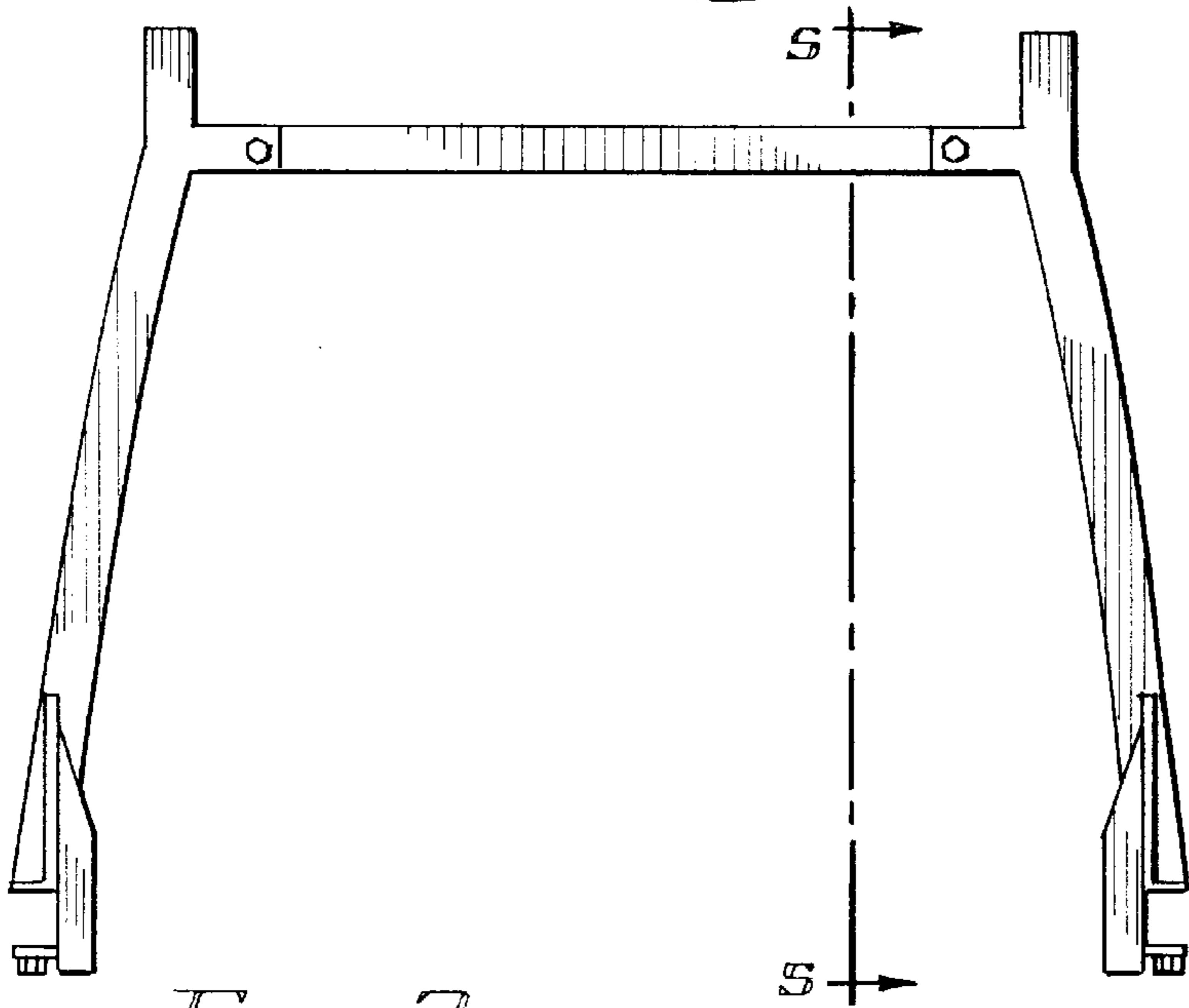

FIG. 2

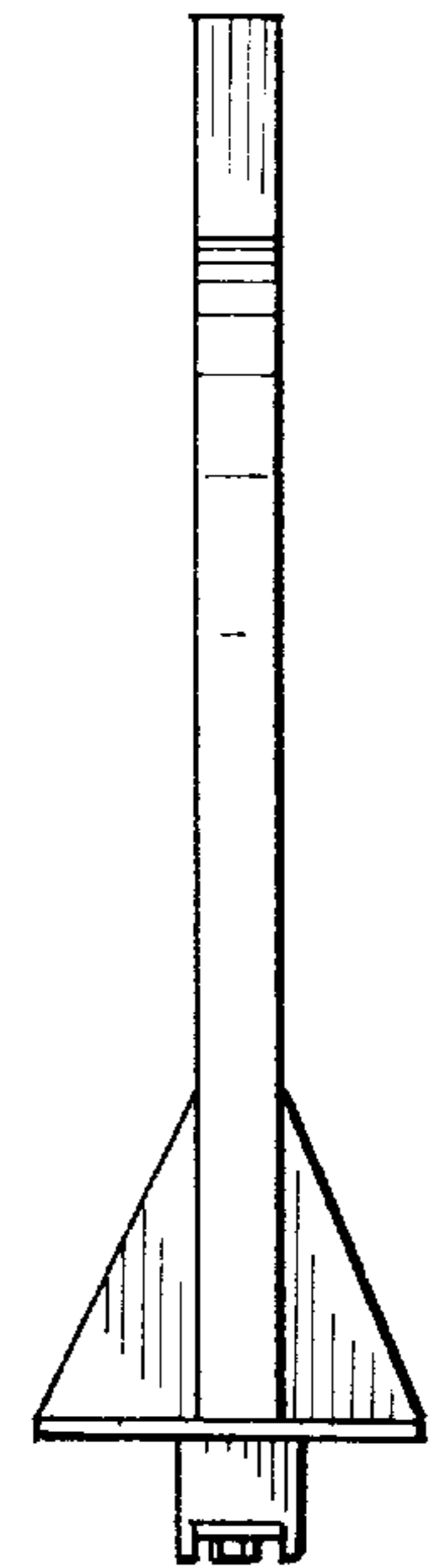

FIG. 3

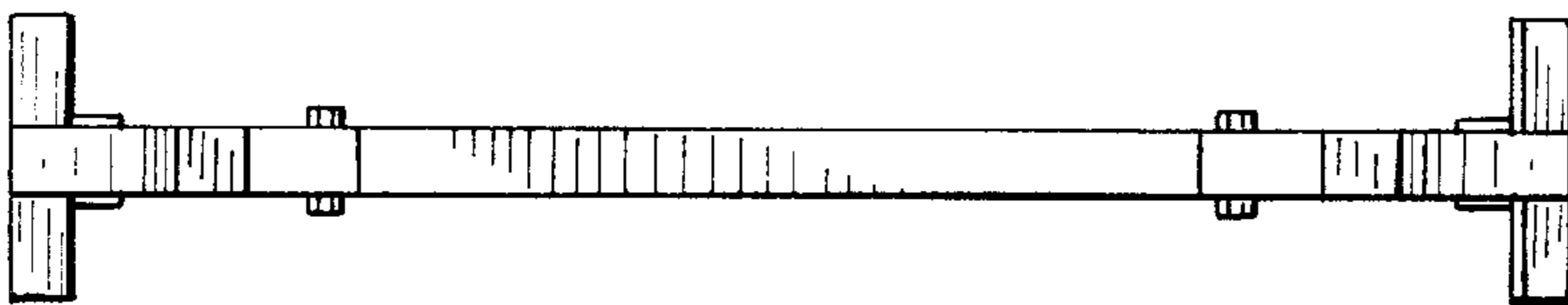

FIG. 4

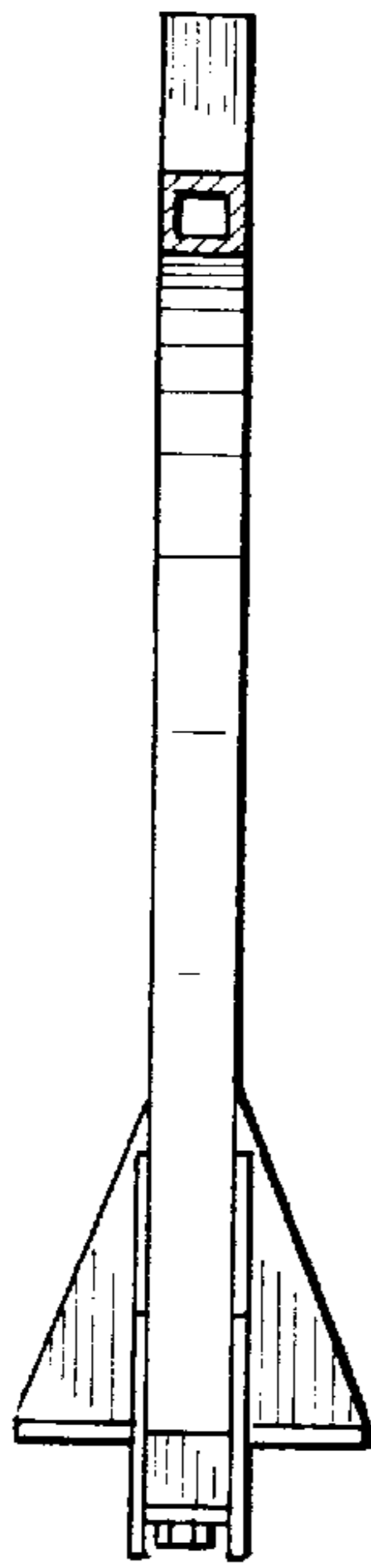

FIG. 5

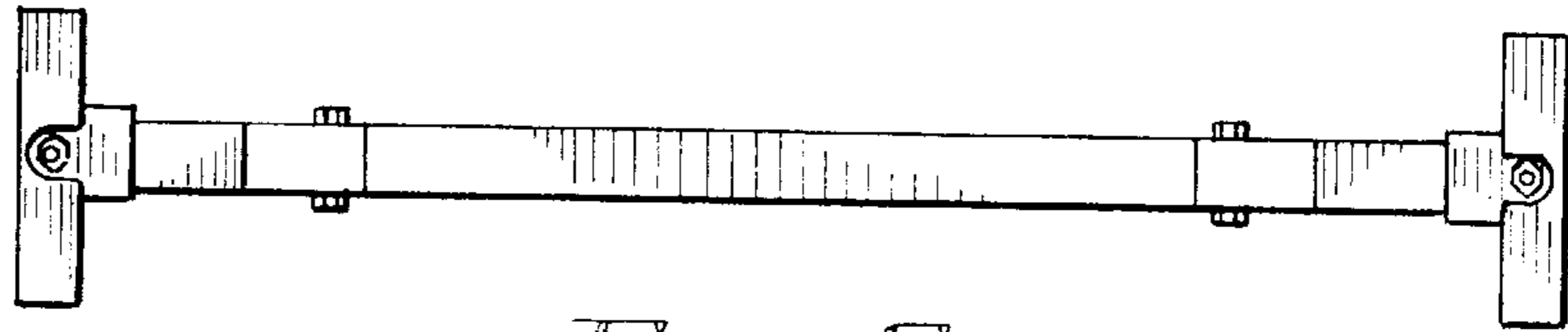

FIG. 6

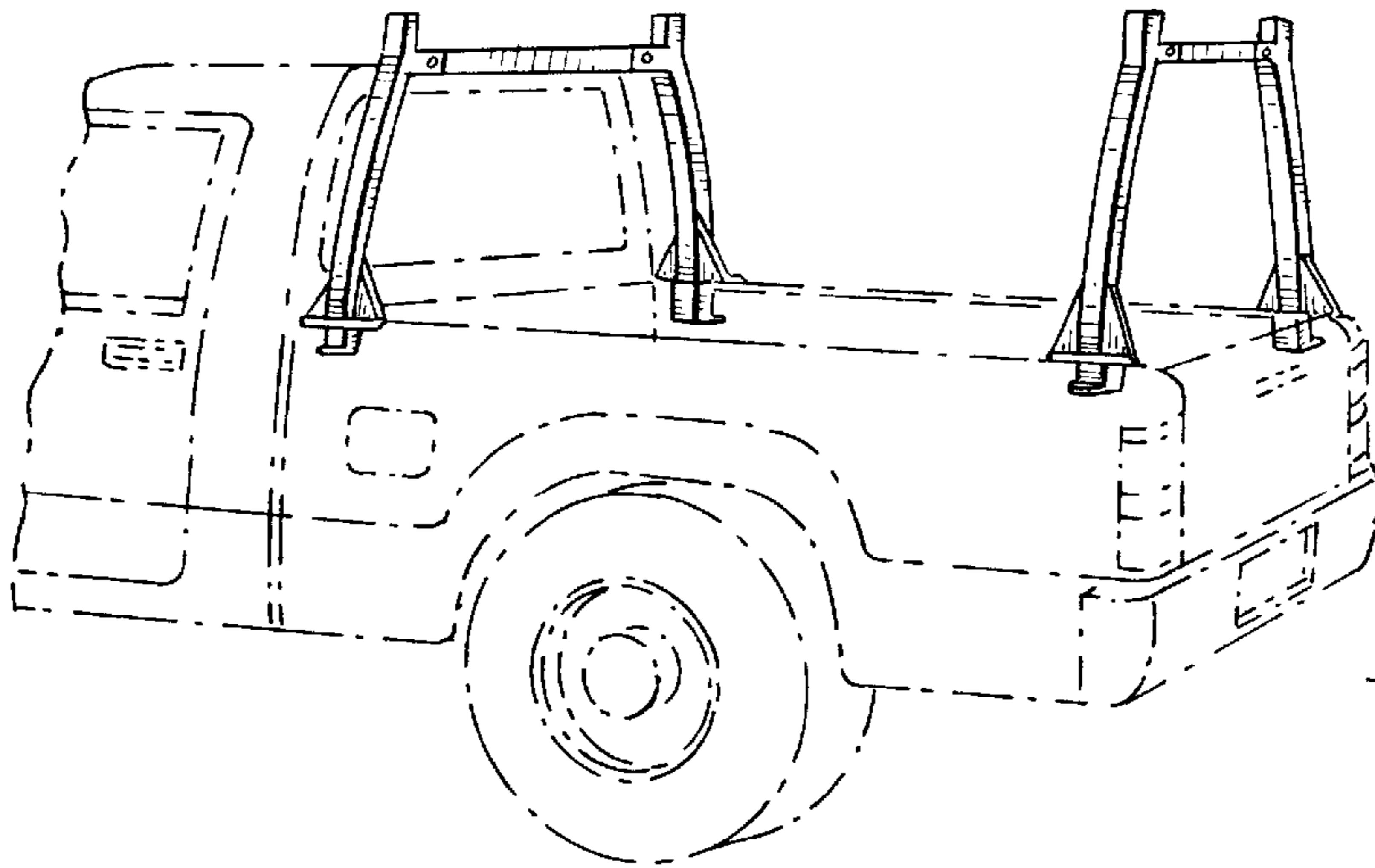

FIG. 7

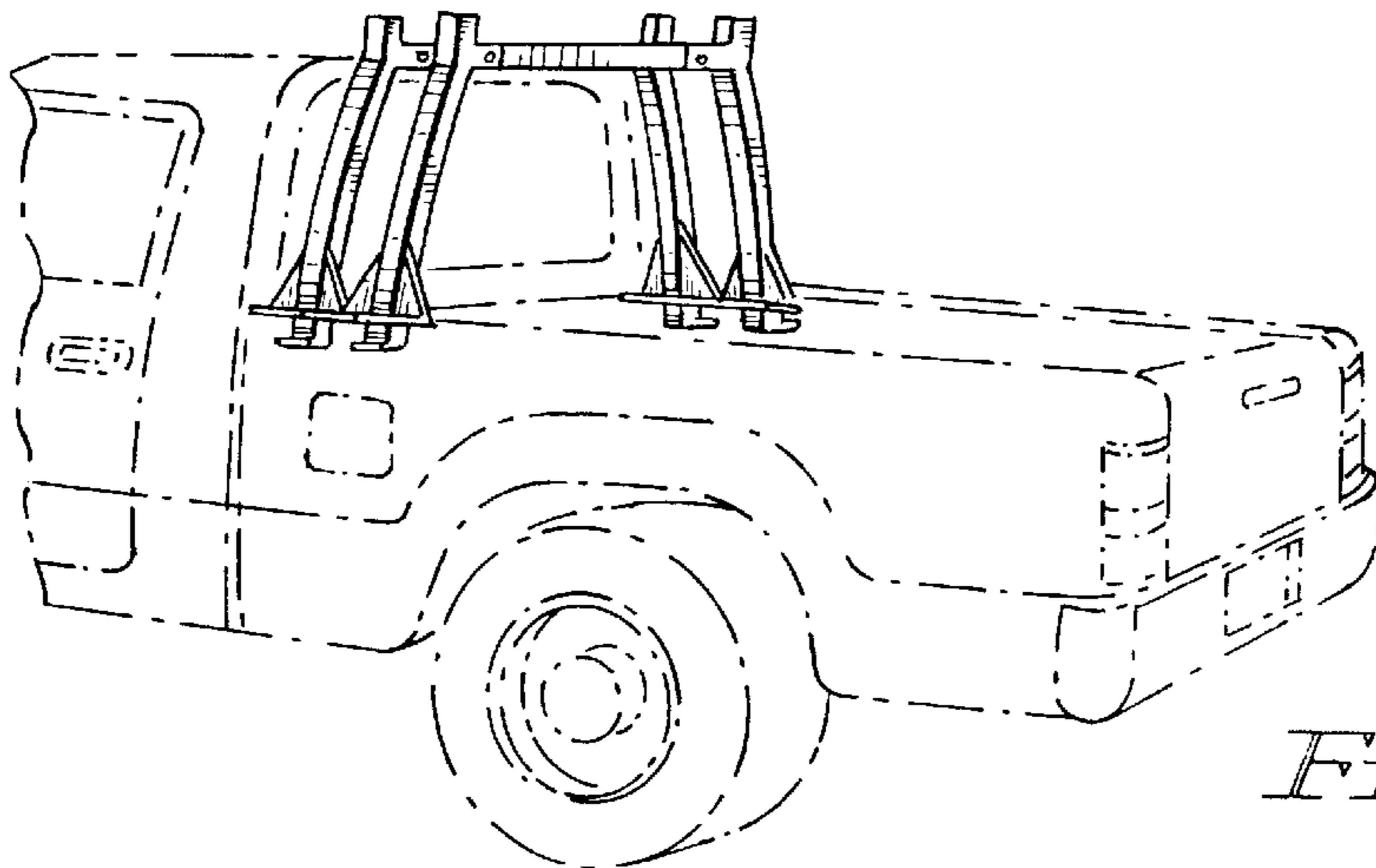

FIG. 8