



US00D398277S

# United States Patent [19] Neeper

[11] **Patent Number: Des. 398,277**

[45] **Date of Patent: \*\*Sep. 15, 1998**

[54] **VEHICLE-WHEEL FRONT FACE**

[75] Inventor: **Mark D. Neeper**, Denver, Colo.

[73] Assignee: **Mobile Hi-Tech Wheels**, Torrance, Calif.

[\*\*] Term: **14 Years**

[21] Appl. No.: **81,551**

[22] Filed: **Jan. 6, 1998**

[51] **LOC (6) Cl.** ..... **12-16**

[52] **U.S. Cl.** ..... **D12/209**

[58] **Field of Search** ..... D12/204-213;  
301/64.1, 65, 37.1

[56] **References Cited**

**U.S. PATENT DOCUMENTS**

D. 311,896	11/1990	Mori	.....	D12/209
D. 366,641	1/1996	Neeper	.....	D12/209
D. 374,420	10/1996	Neeper	.....	D12/209
D. 377,640	1/1997	Neeper	.....	D12/209
D. 380,724	7/1997	Brown et al.	.....	D12/209
D. 384,631	10/1997	Cullen	.....	D12/209
D. 384,928	10/1997	Neeper	.....	D12/209
D. 384,930	10/1997	Hale, Jr.	.....	D12/209

D. 385,246	10/1997	Neeper	.....	D12/209
D. 385,842	11/1997	Cullen	.....	D12/209
D. 386,740	11/1997	Cullen	.....	D12/209
D. 390,822	2/1998	Neeper	.....	D12/209

*Primary Examiner*—James Gandy  
*Assistant Examiner*—Stacia Sinuik  
*Attorney, Agent, or Firm*—Christie, Parker & Hale, LLP

[57] **CLAIM**

The ornamental design for vehicle-wheel front face, as shown and described.

**DESCRIPTION**

FIG. 1 is a perspective view of a vehicle-wheel front face according to my new design;  
FIG. 2 is an enlarged front elevational view thereof;  
FIG. 3 is an enlarged side view taken from the left side of FIG. 2, it being understood that the opposite side is a mirror image thereof; and,  
FIG. 4 is a front elevational view of a second embodiment of my new design, with the only difference being a reversed curvature of the wheel spokes.  
Portions of the wheel depicted in broken line are for illustrative purposes only, and form no part of the claimed design.

**1 Claim, 4 Drawing Sheets**

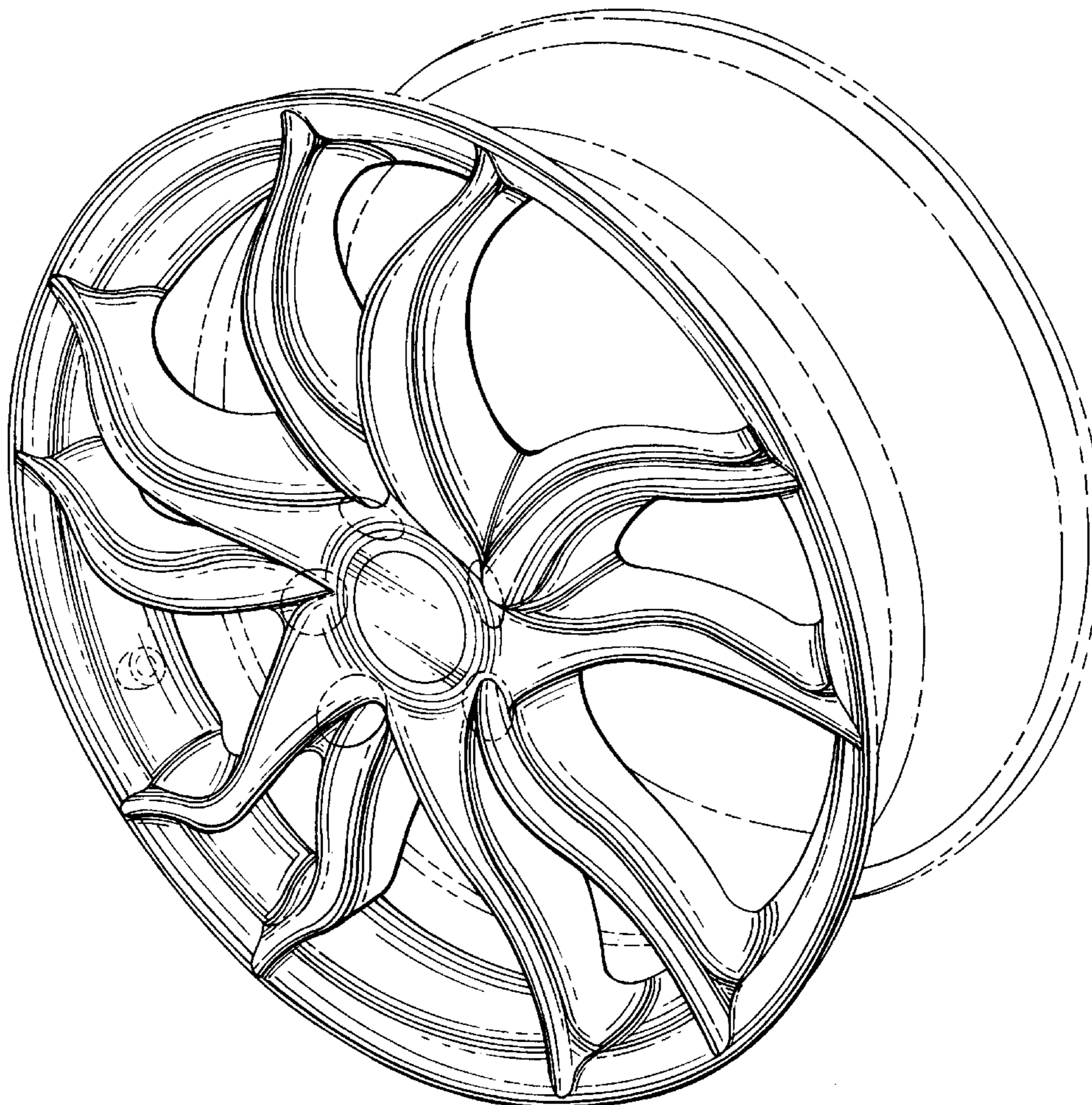

*Fig. 1*

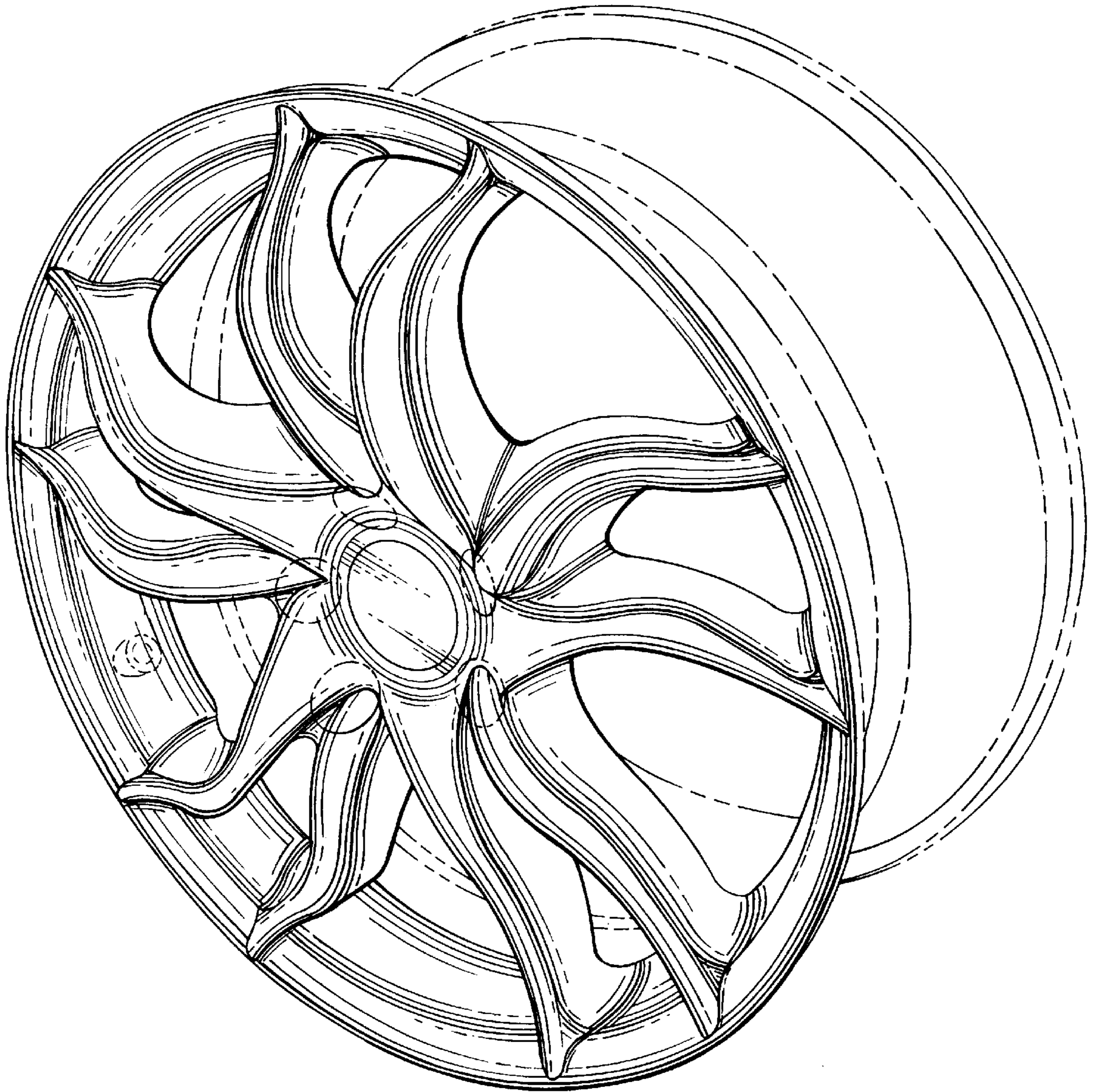

*FIG. 2*

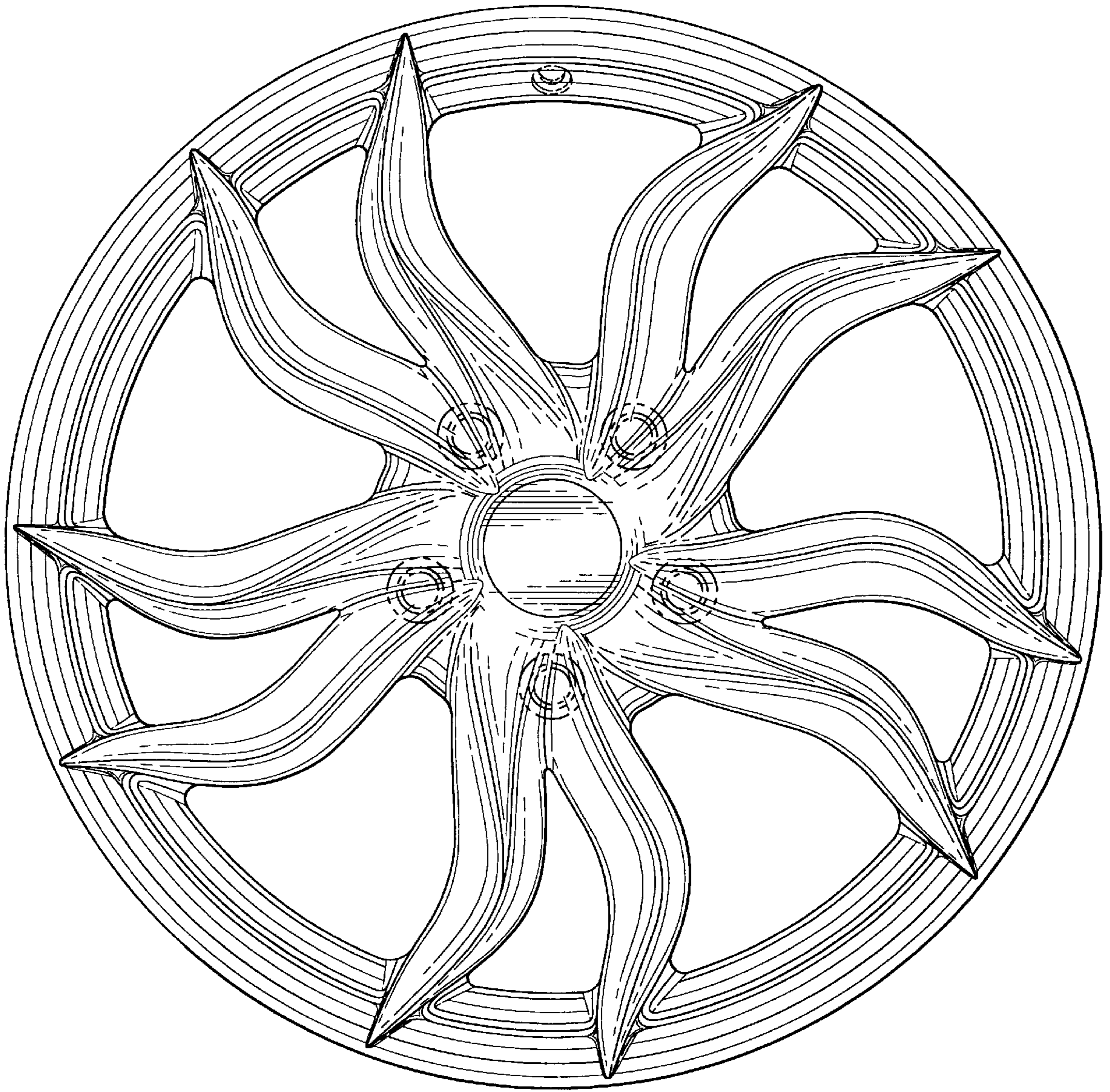

*FIG. 3*

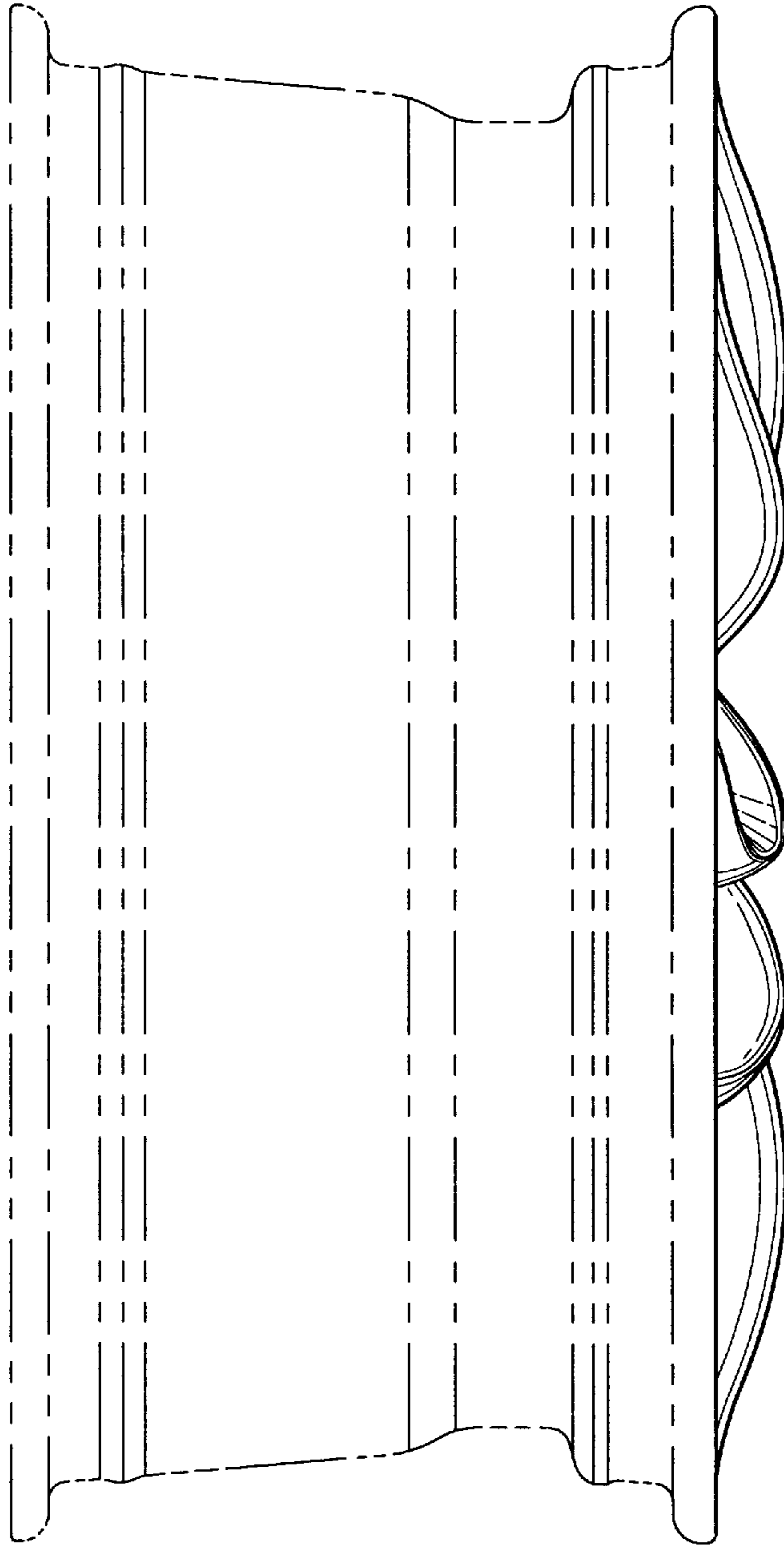

*FIG. 4*

