



US00D398265S

United States Patent [19]

[11] Patent Number: Des. 398,265

Robb et al.

[45] Date of Patent: **Sep. 15, 1998

[54] MOTORCYCLE BODY

[57] CLAIM

[75] Inventors: **David Robb**, München; **Dietmar Finger**, Rödermark, both of Germany

The ornamental design for a motorcycle body, as shown and described.

[73] Assignee: **Bayerische Motoren Werke Aktiengesellschaft**, Munich, Germany

DESCRIPTION

[**] Term: **14 Years**

FIG. 1 is a left side view of a motorcycle body according to our novel design;

[21] Appl. No.: **72,507**

FIG. 2 is a perspective view from the front left side of the motorcycle body according to our novel design;

[22] Filed: **Jun. 19, 1997**

FIG. 3 is a perspective view from the rear left side of the motorcycle body according to our novel design;

[30] Foreign Application Priority Data

FIG. 4 is a right side view of the motorcycle body according to our novel design;

Dec. 19, 1996 [DE] Germany M 96 11 043.0

FIG. 5 is a perspective view from the front right side of the motorcycle body according to our novel design;

[51] LOC (6) Cl. **12-11**

FIG. 6 is a perspective view from the rear right side of the motorcycle body according to our novel design;

[52] U.S. Cl. **D12/110**

FIG. 7 is a front view of the motorcycle body according to our novel design;

[58] Field of Search D12/110; 280/219

FIG. 8 is a rear view of the motorcycle body according to our novel design;

[56] References Cited

U.S. PATENT DOCUMENTS

D. 298,114	10/1988	Abe et al.	D12/110
D. 321,849	11/1991	Abe et al.	D12/110
D. 325,363	4/1992	Yamada et al.	D12/110
D. 341,798	11/1993	Murata et al.	D12/110
D. 350,918	9/1994	Kohama et al.	D12/110
D. 383,096	9/1997	Abe et al.	D12/110
D. 385,227	10/1997	Katoh	D12/110

FIG. 9 is a top view of the motorcycle body according to our novel design;

FIG. 10 is a left side view of the motorcycle body with the backrest shown in downright position according to our novel design; and,

FIG. 11 is a right side view of the motorcycle body with the backrest shown in downright position according to our novel design.

Primary Examiner—Melody N. Brown

Features shown in broken lines depict the environment and do not form part of the claimed design.

Attorney, Agent, or Firm—Evenson, McKeown Edwards & Lenahan, PLLC

1 Claim, 10 Drawing Sheets

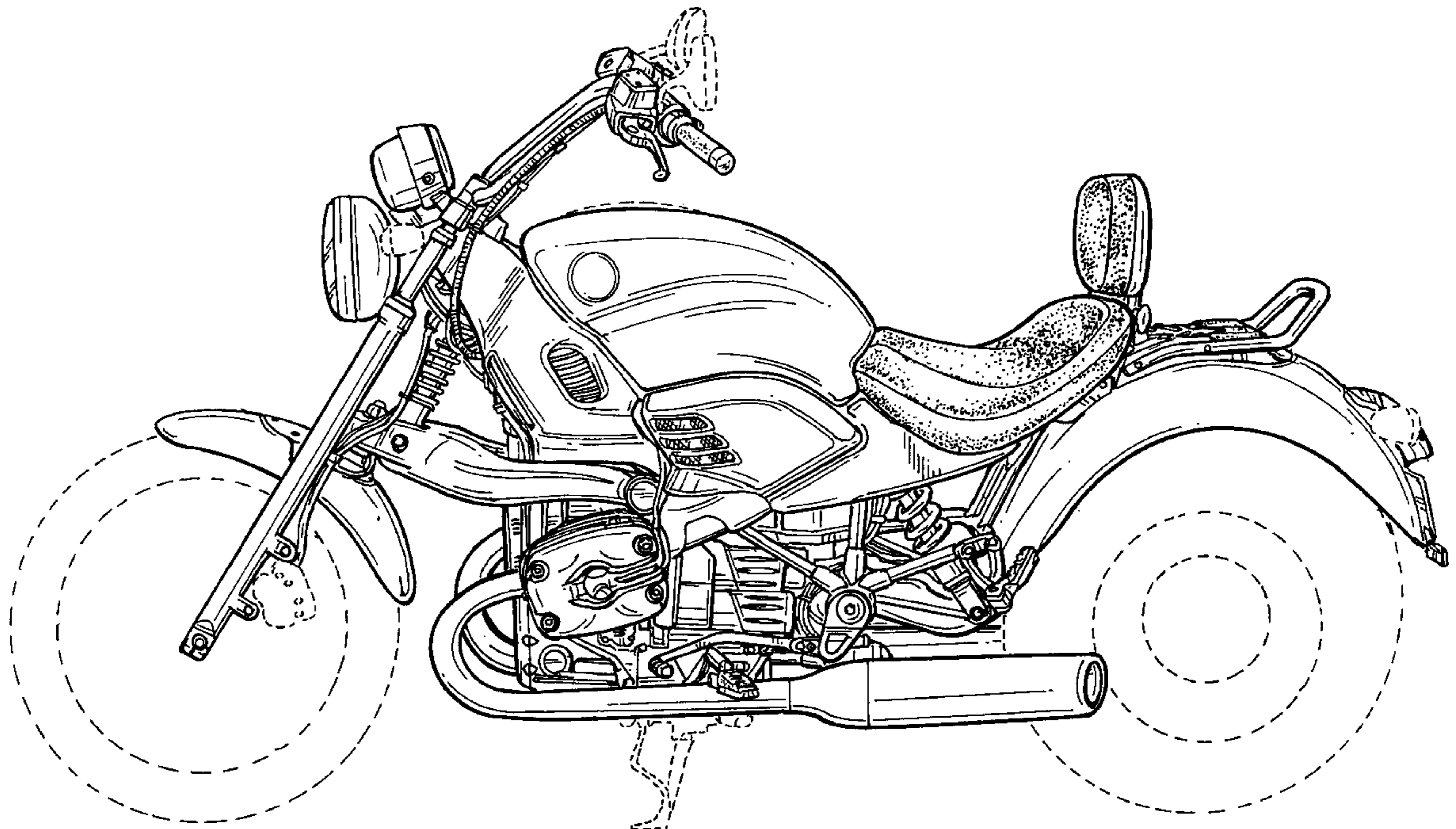

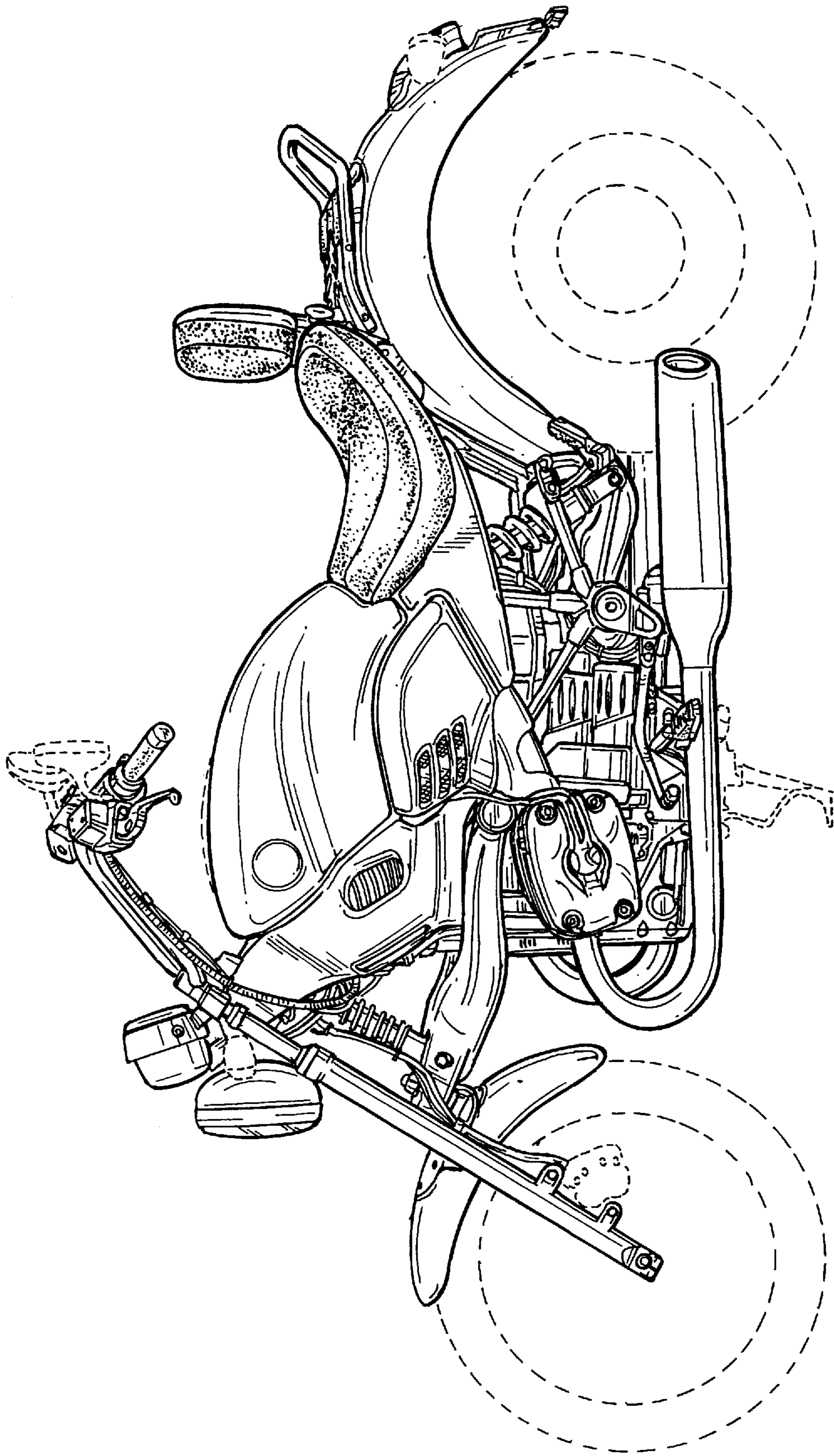

FIG.1

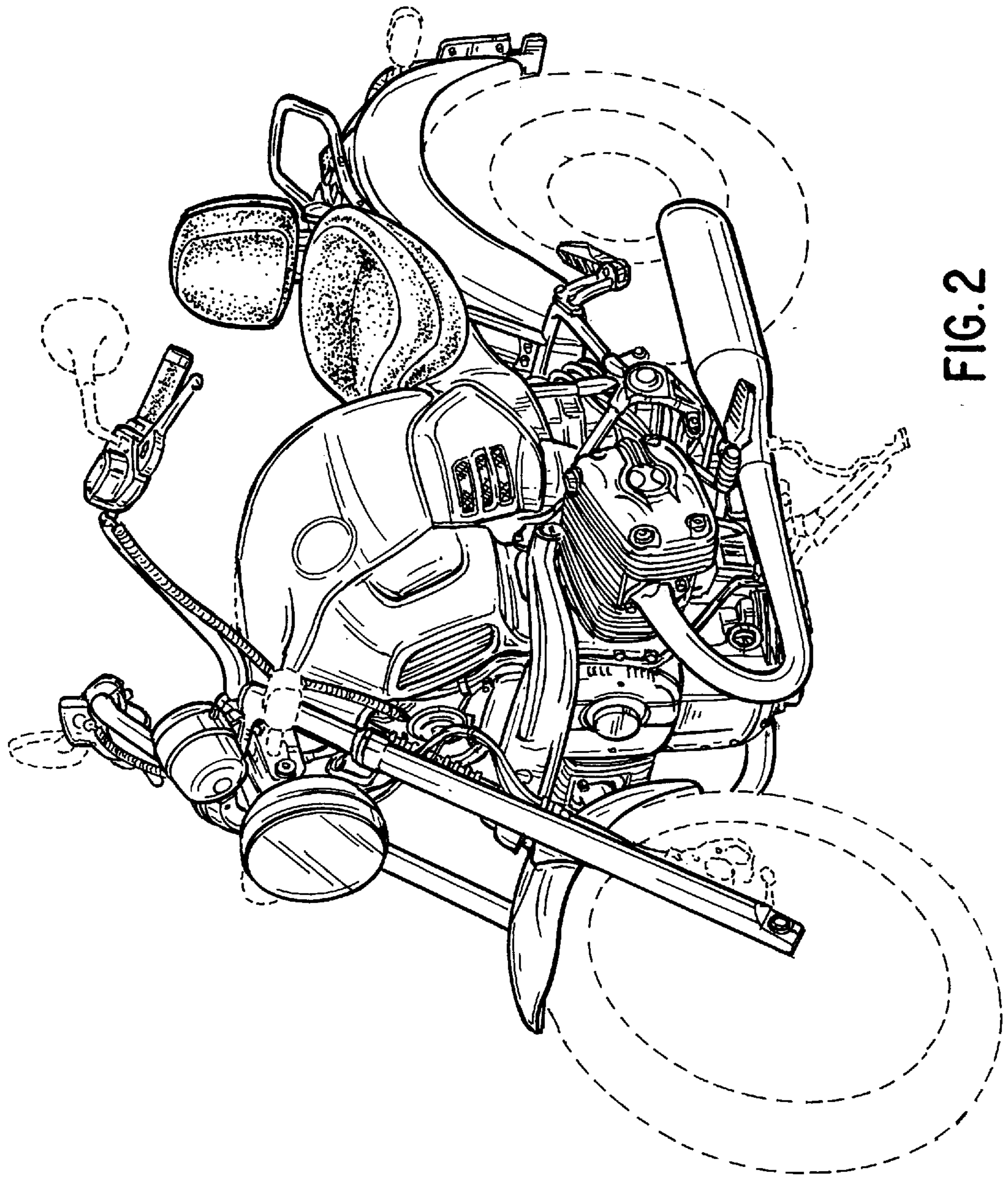

FIG. 2

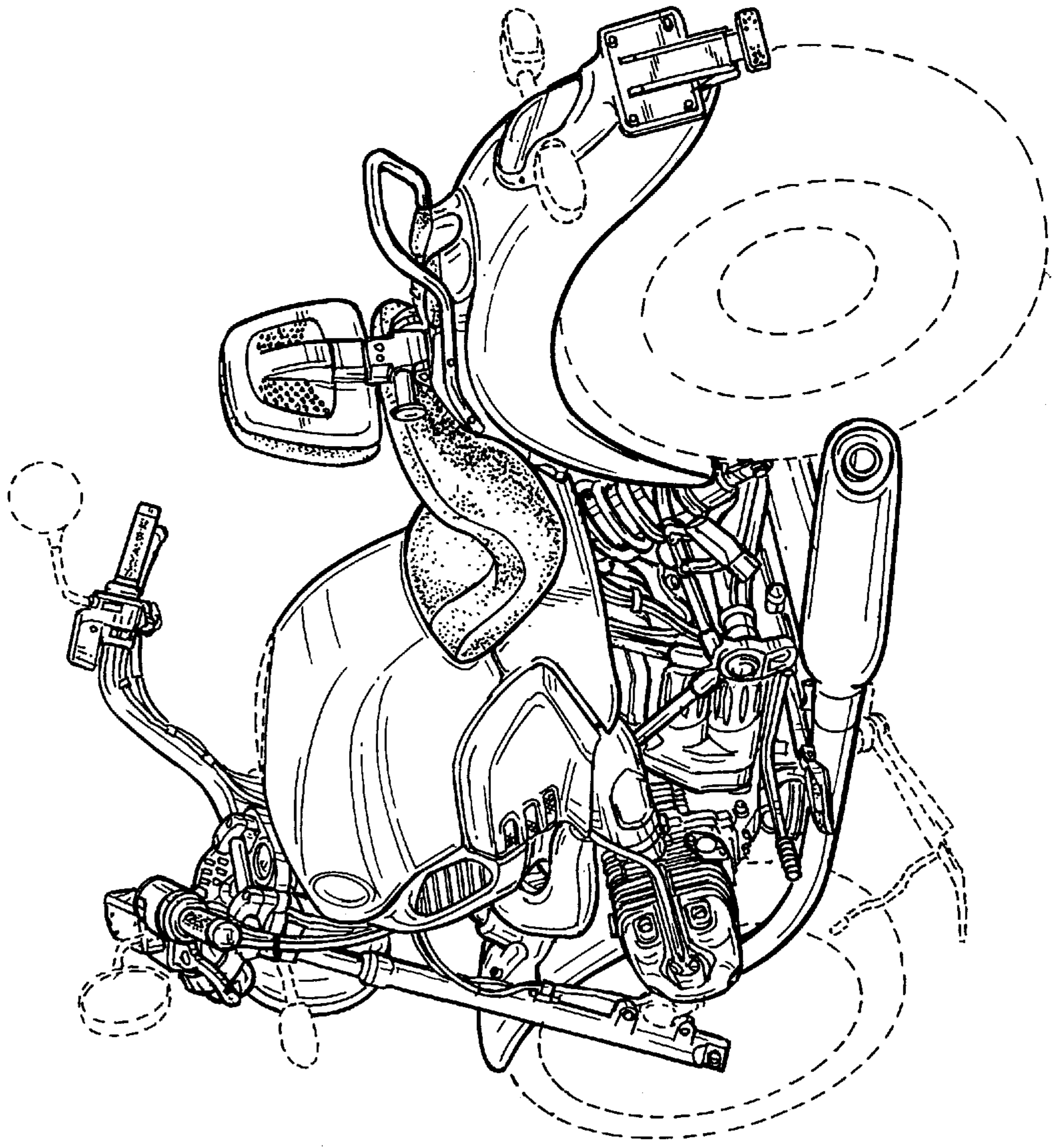

FIG. 3

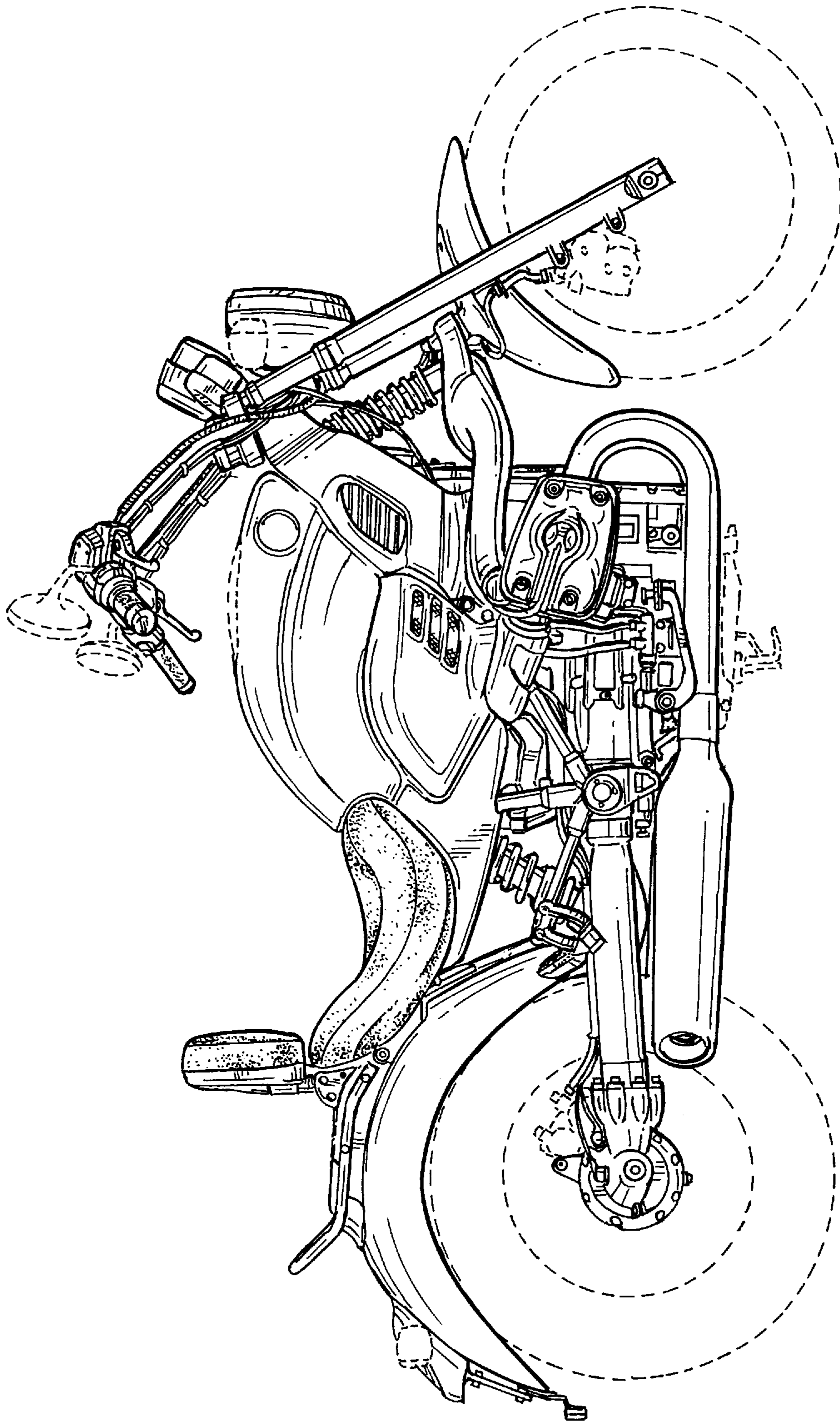

FIG. 4

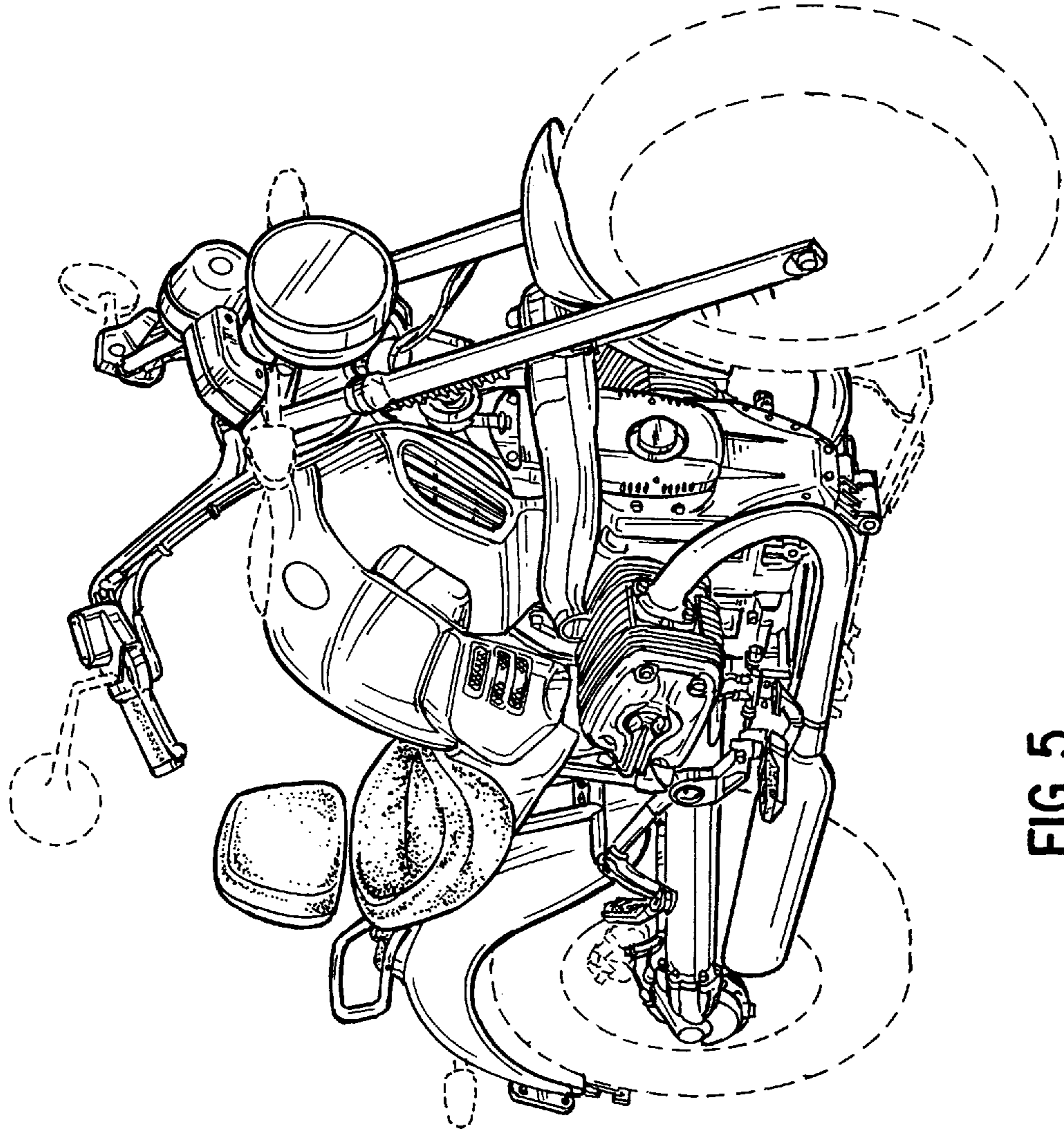

FIG. 5

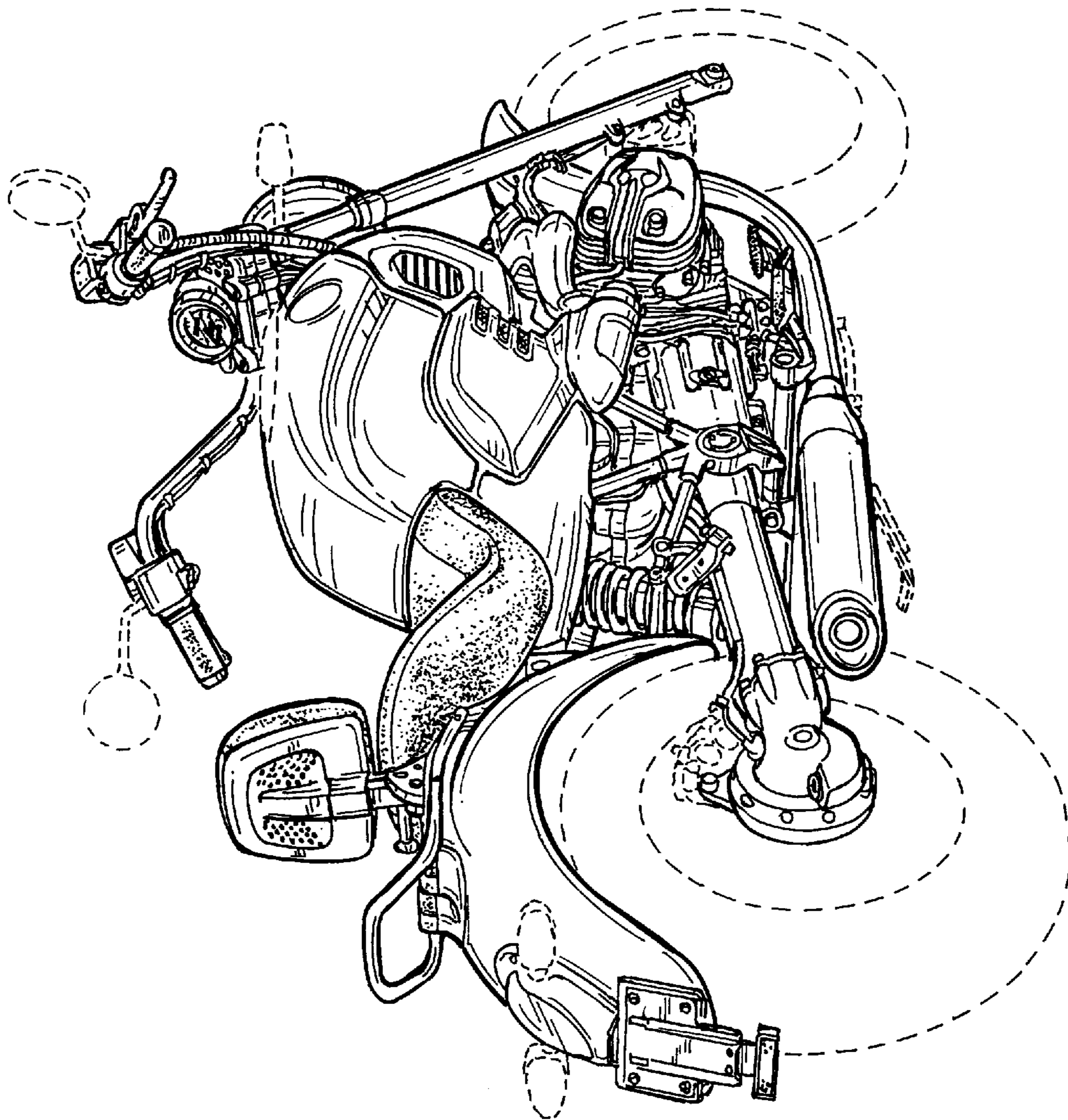

FIG. 6

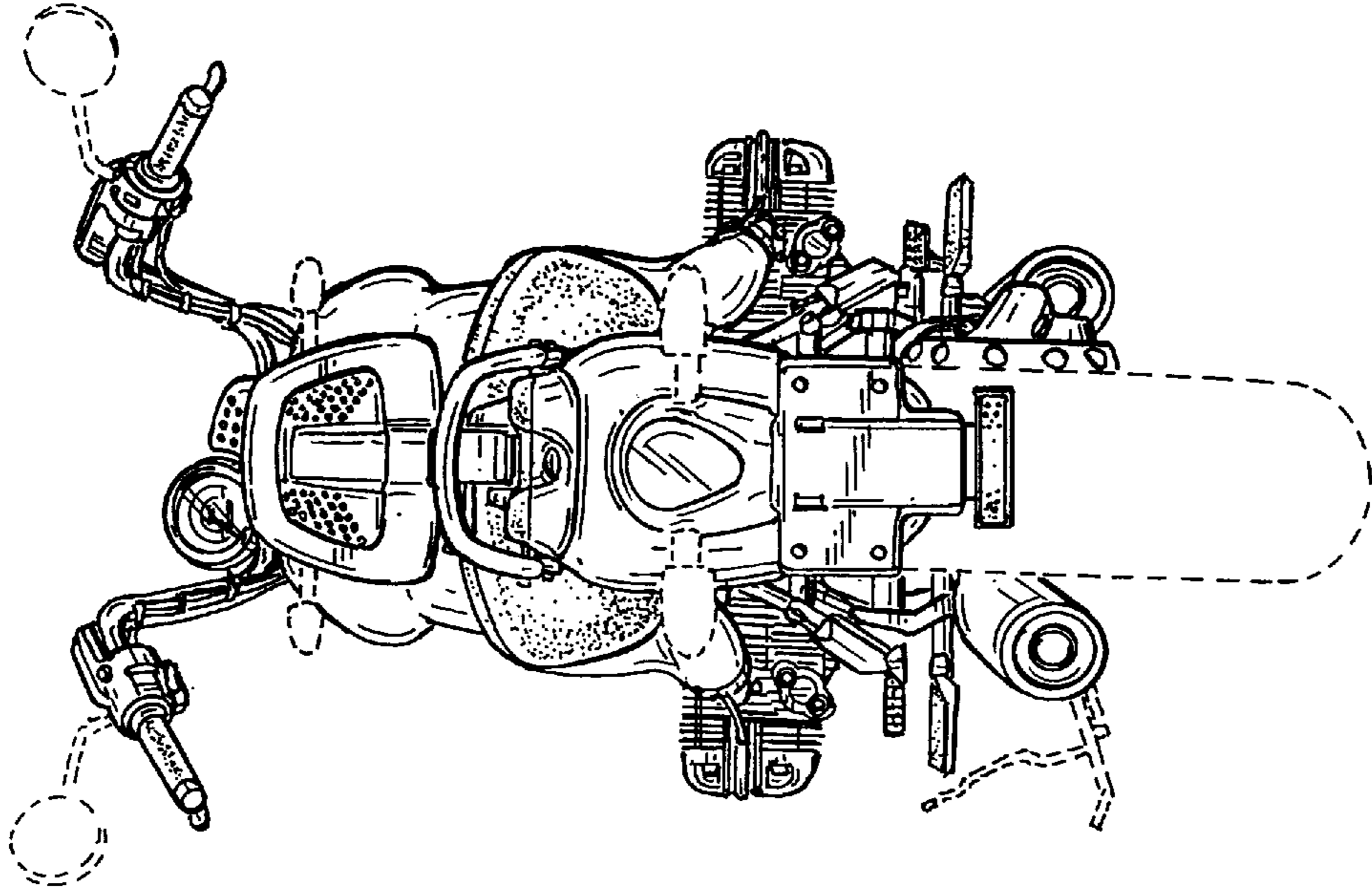

FIG. 8

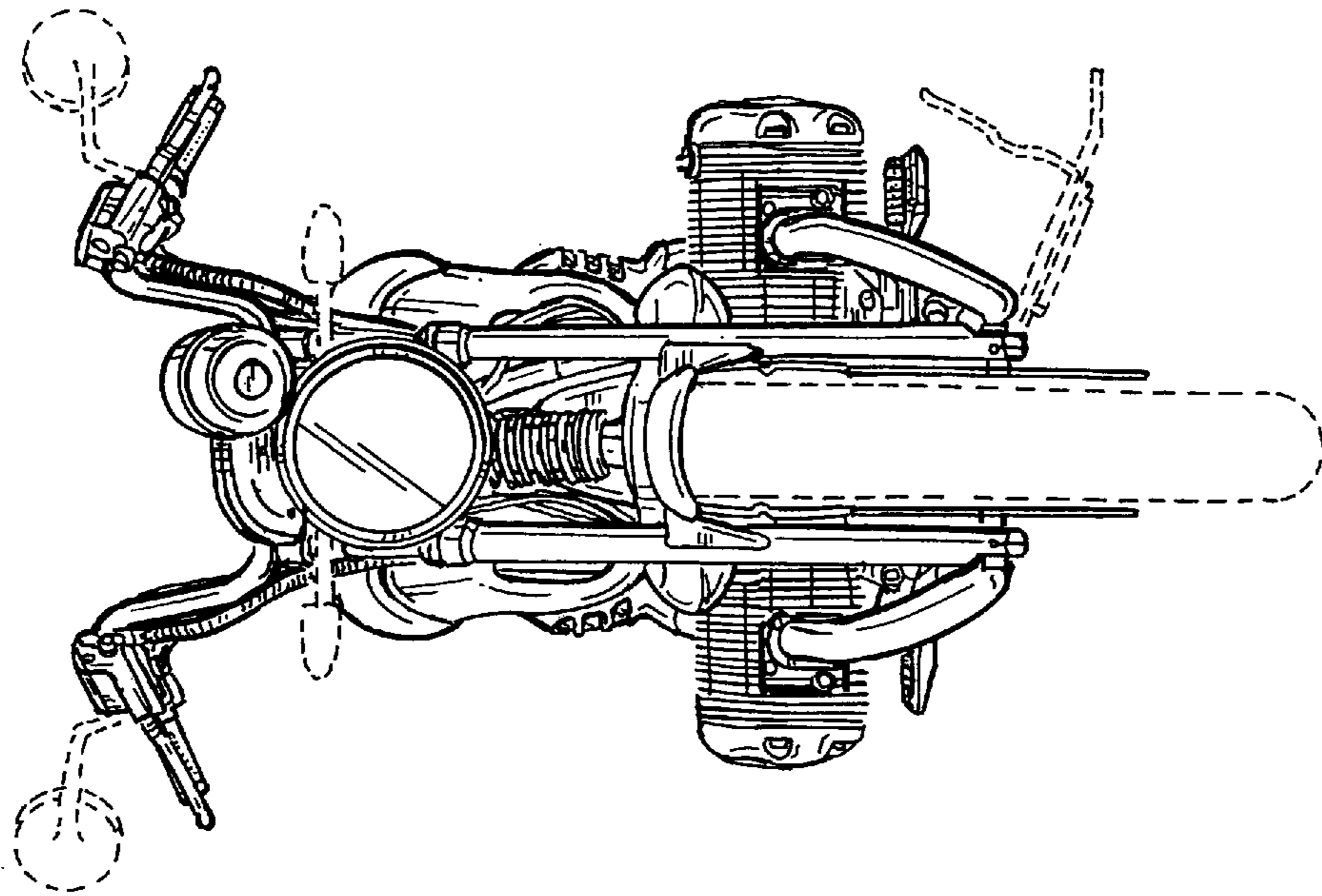

FIG. 7

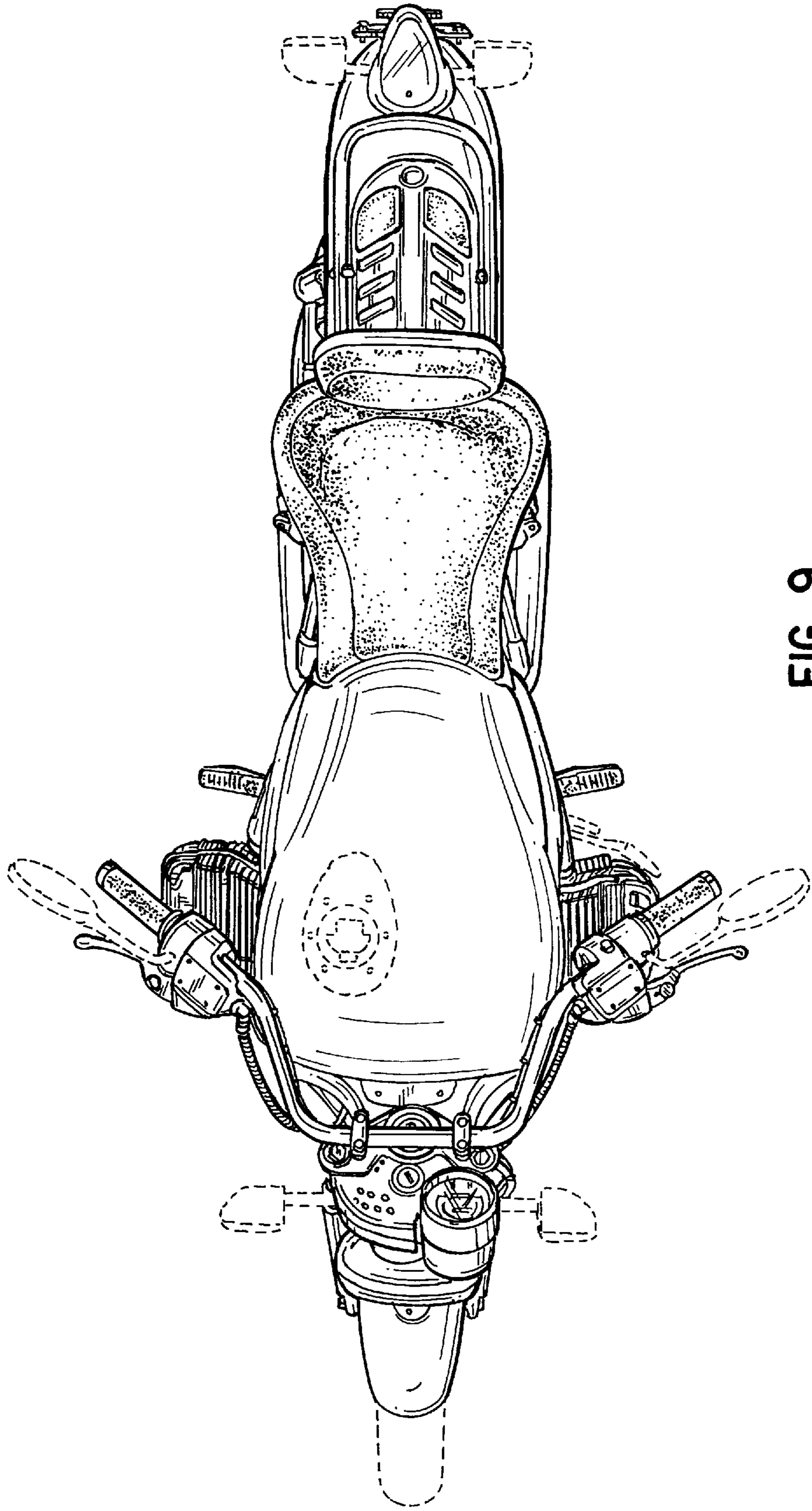

FIG. 9

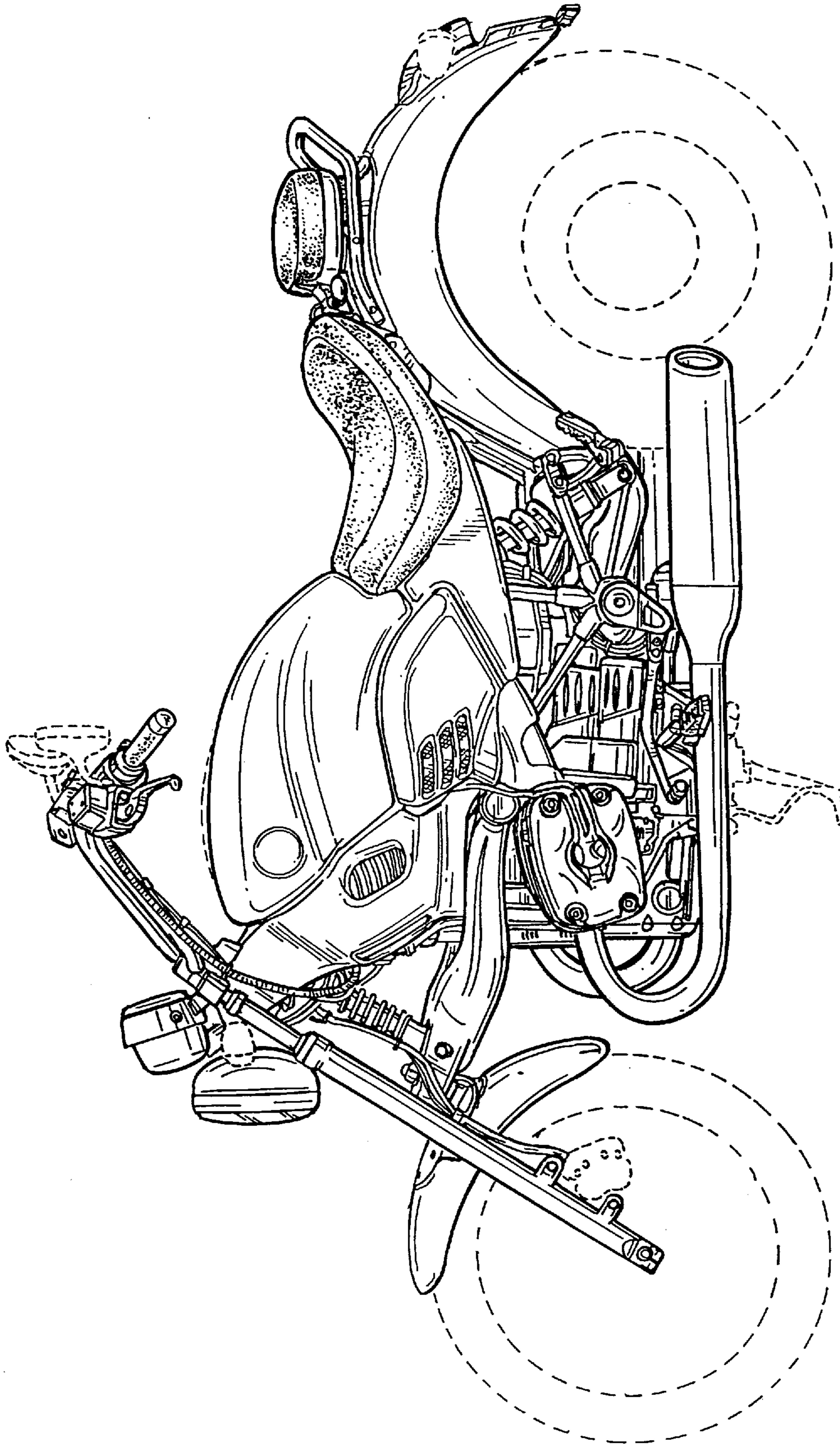

FIG. 10

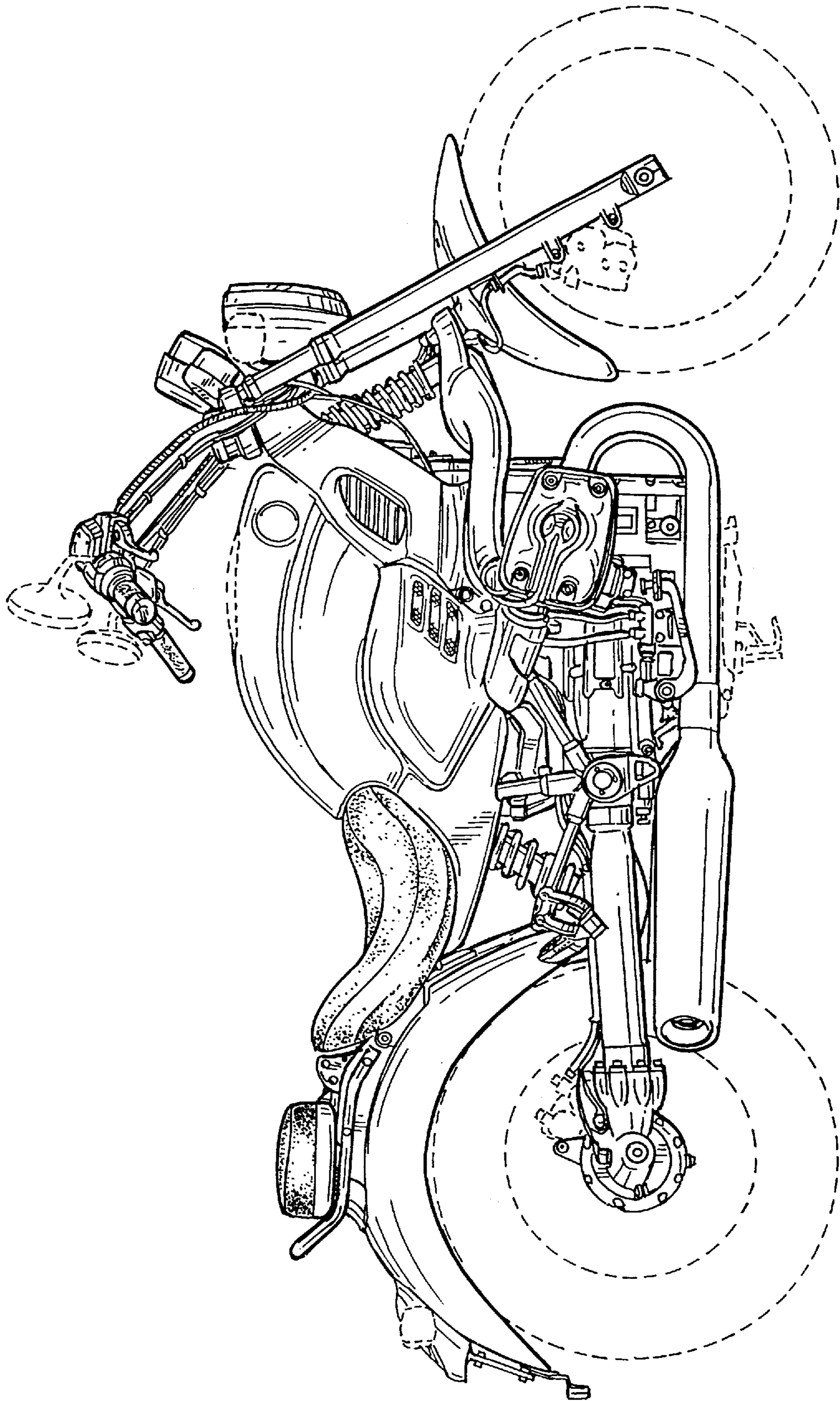

FIG. 11