



US00D397988S

United States Patent [19]

Brooks et al.

[11] **Patent Number: Des. 397,988**

[45] **Date of Patent: **Sep. 8, 1998**

[54] **BOAT**

D. 341,566 11/1993 Brooks et al. D12/315

[75] Inventors: **Benedict A. Brooks**, N8765 CO. VV, Berlin, Wis. 54923; **Robert F. Hargrave**; **William L. Brooks**, both of Berlin, Wis.

OTHER PUBLICATIONS

A Prout Ad entitled "For Luxury-Speed-Stability", undated, admitted prior art.

[73] Assignee: **Benedict A. Brooks**, Berlin, Wis.

Primary Examiner—Kay H. Chin
Attorney, Agent, or Firm—Quarles & Brady

[**] Term: **14 Years**

[57] CLAIM

The ornamental design for a boat, as shown and described.

[21] Appl. No.: **76,645**

DESCRIPTION

[22] Filed: **Sep. 15, 1997**

[51] **LOC (6) Cl.** **12-06**

FIG. 1 is a perspective view taken from the top, front and left side of a boat showing our new design;

[52] **U.S. Cl.** **D12/315; D12/310**

FIG. 2 is a left side elevational view thereof, the right side elevational view being a mirror image of the side shown;

[58] **Field of Search** D12/300, 304, D12/309, 310, 315, 318; 114/60, 61, 292, 62, 271, 343, 355, 356, 357, 56

FIG. 3 is a top plan view thereof;
FIG. 4 is a front elevational view thereof; and,
FIG. 5 is a rear elevational view thereof.

The dotted line showing of holes in FIGS. 1, 2 and 3 are for purposes of illustration only.

[56] References Cited

U.S. PATENT DOCUMENTS

D. 331,905 12/1992 Pruin et al. D12/315

1 Claim, 3 Drawing Sheets

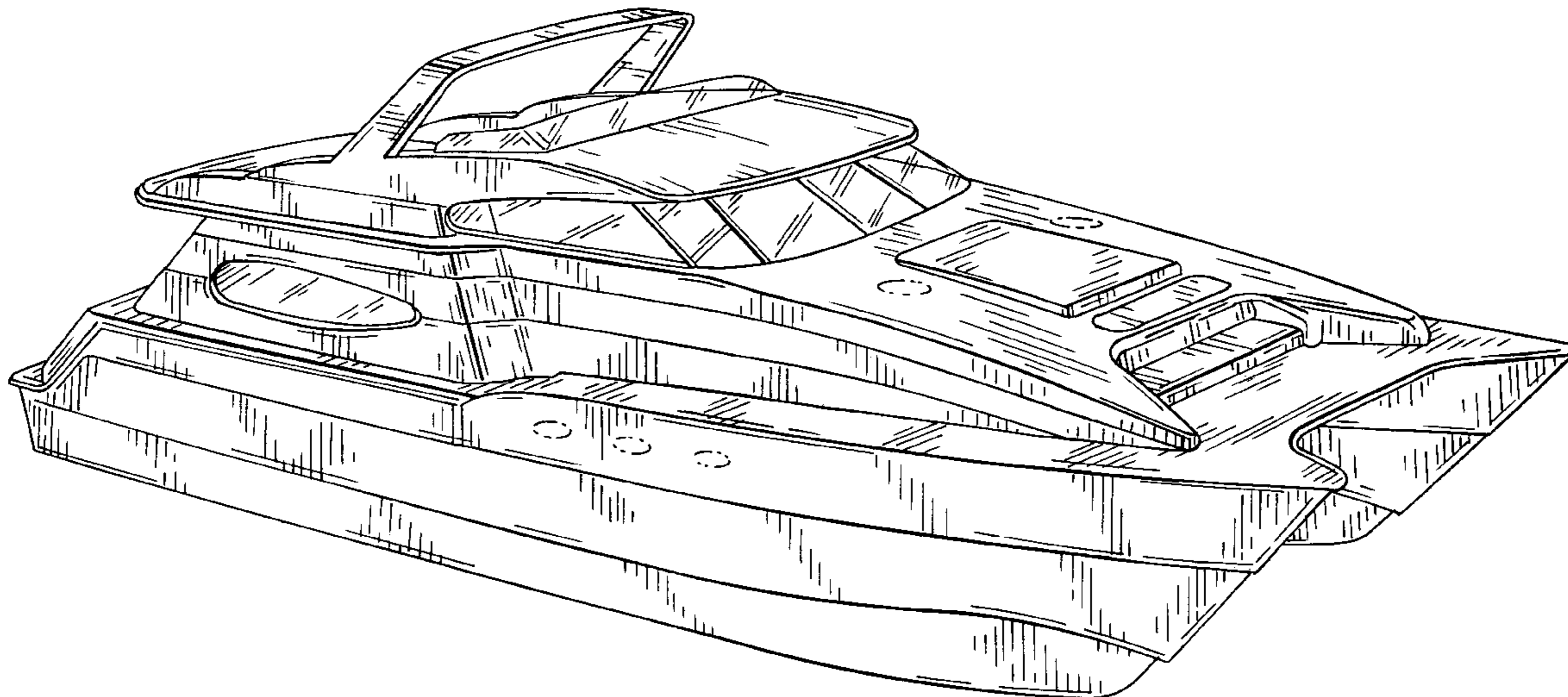

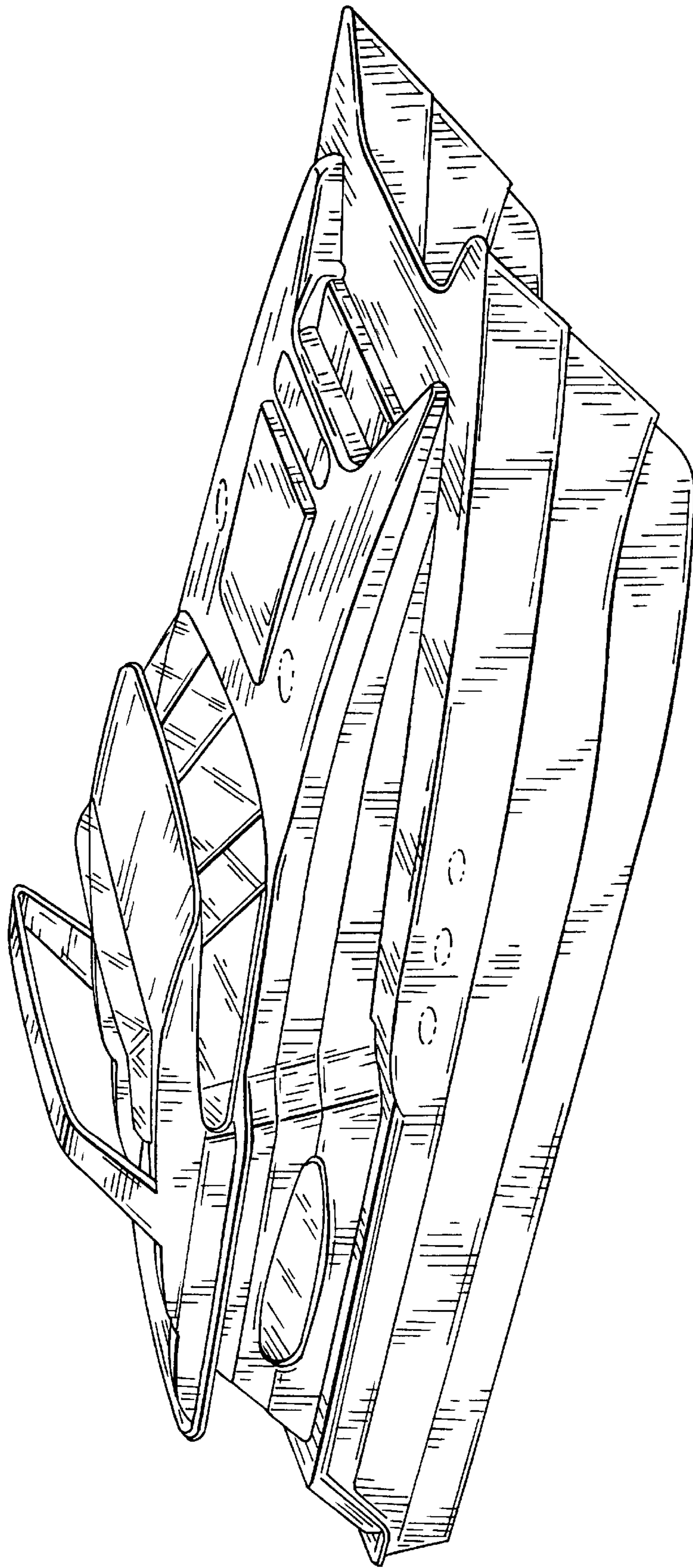

FIG. 1

FIG. 2

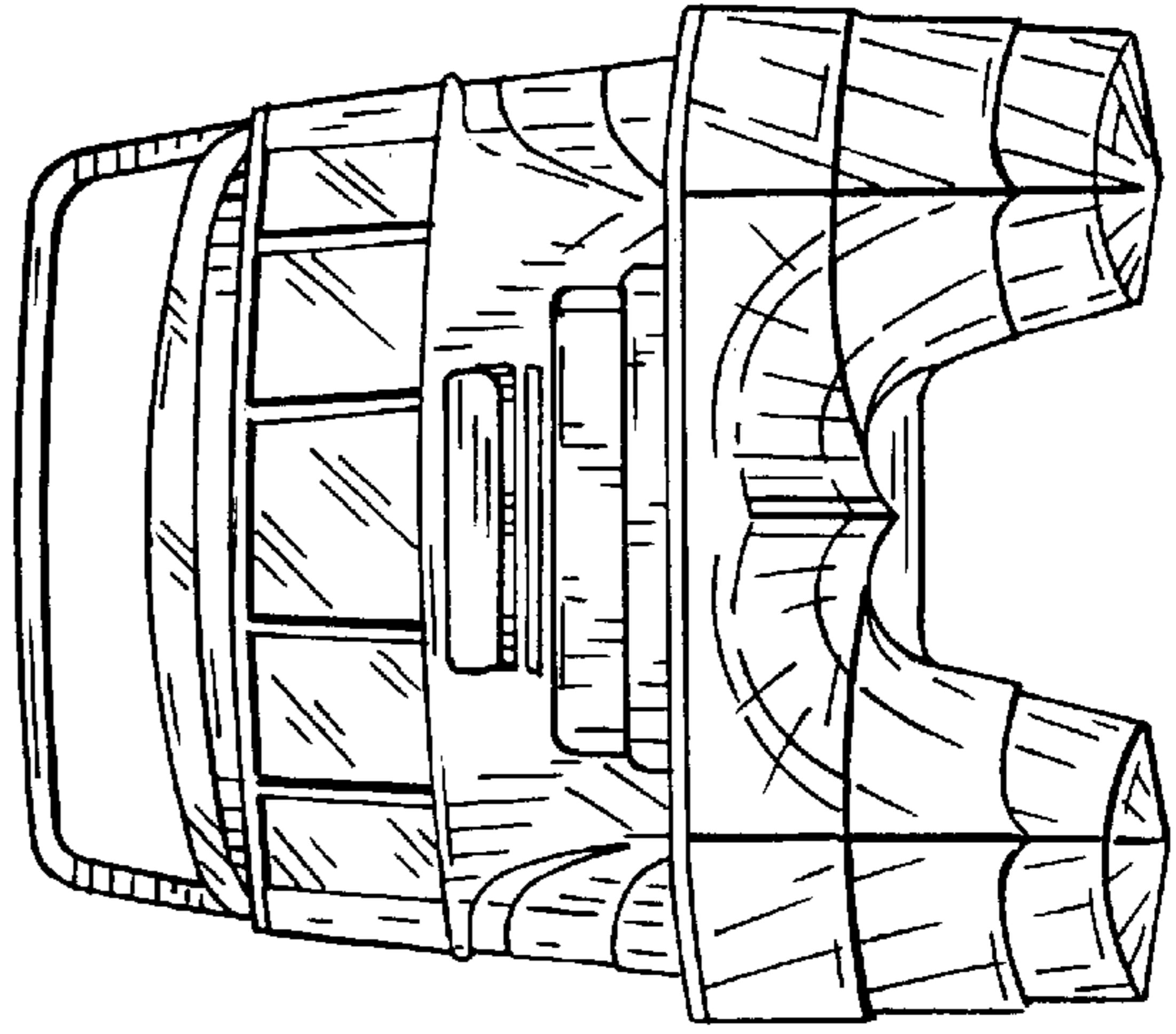
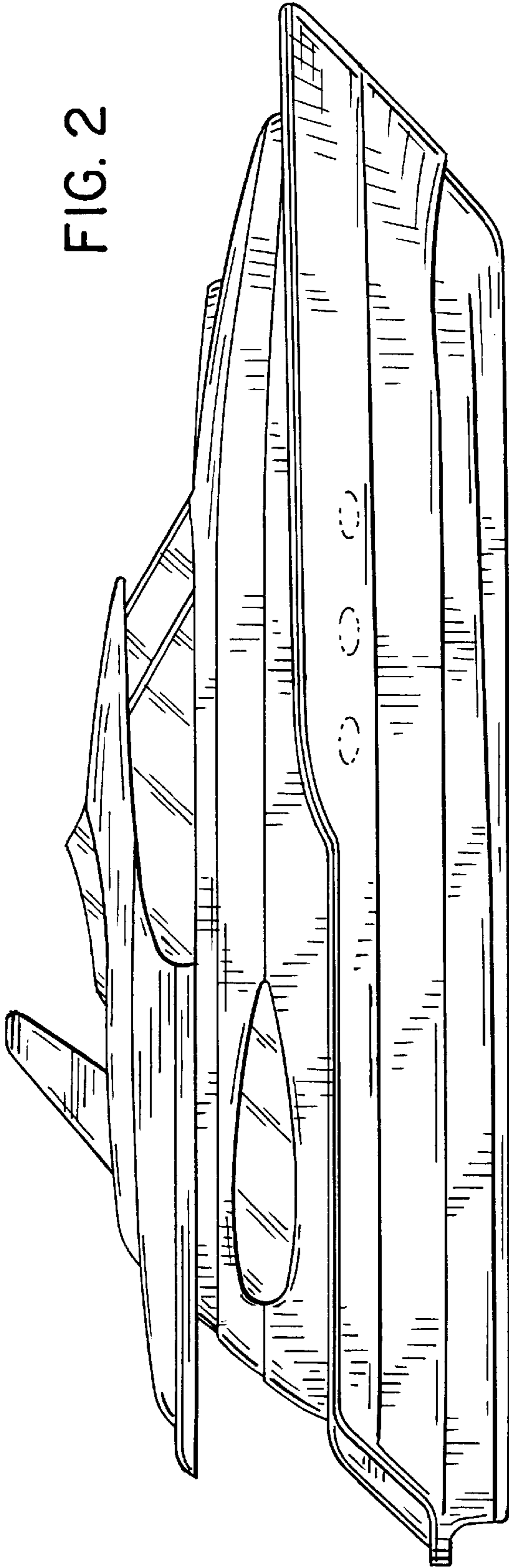

FIG. 4

FIG. 3

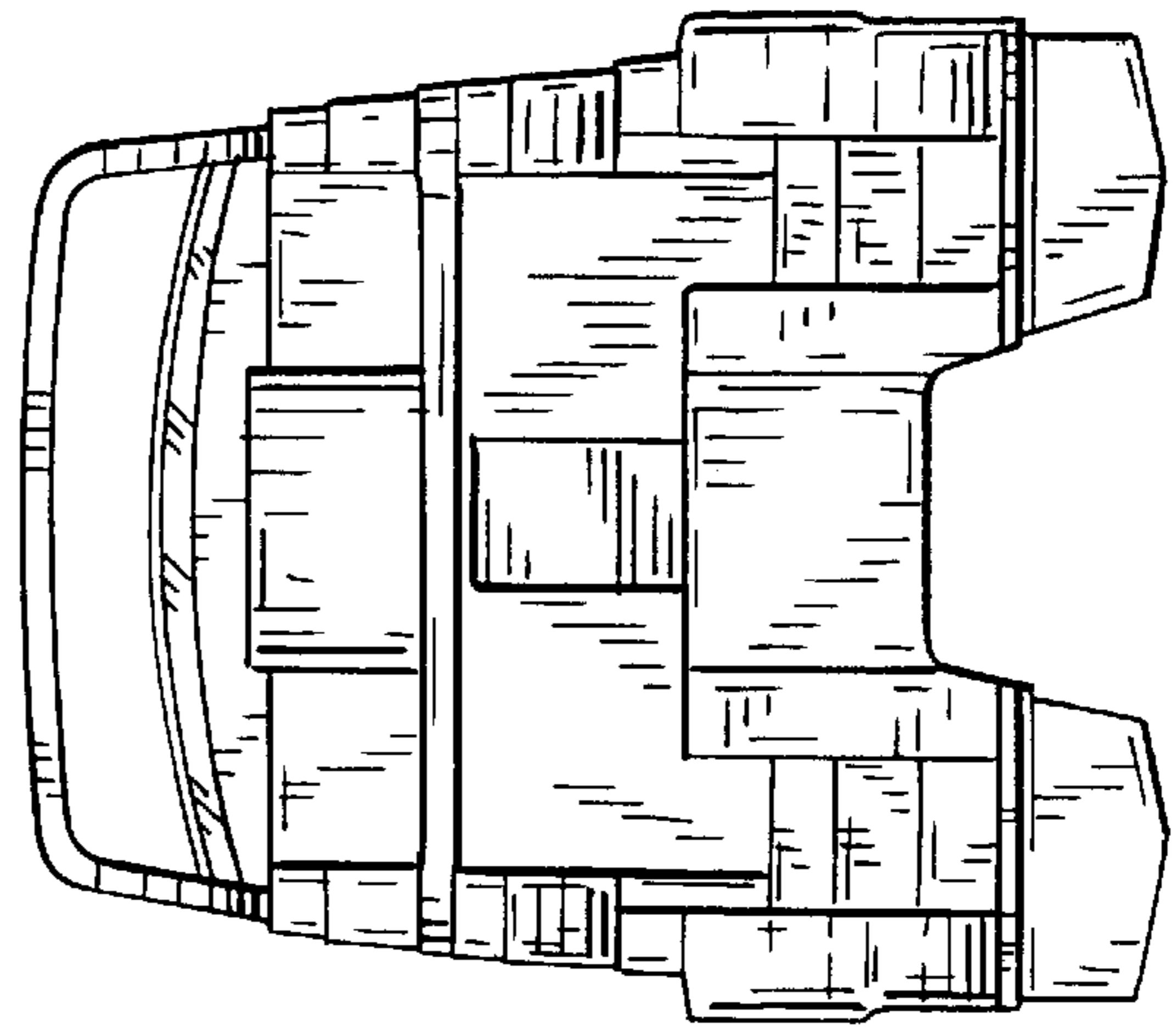
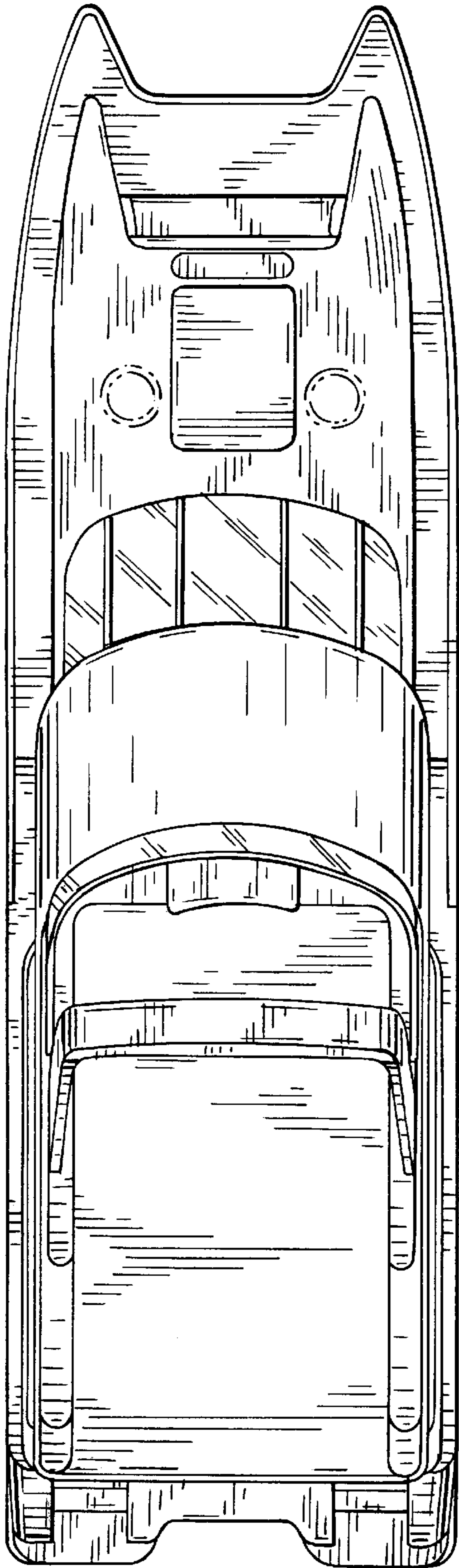

FIG. 5