



US00D397986S

# United States Patent [19] Henry

[11] **Patent Number:** **Des. 397,986**

[45] **Date of Patent:** **\*\*Sep. 8, 1998**

[54] **CLEAT FOR A WHEEL CHOCK**

[76] Inventor: **Stephen K. Henry**, 3815 Northbrook Dr. C-21, Boulder, Colo. 80302

[\*\*] Term: **14 Years**

[21] Appl. No.: **78,687**

[22] Filed: **Oct. 30, 1997**

[51] **LOC (6) Cl.** ..... **12-06**

[52] **U.S. Cl.** ..... **D12/217**

[58] **Field of Search** ..... D12/114, 120, D12/217; 188/4 R, 32; 267/139, 140; 280/293; 410/30, 49

[56] **References Cited**

**U.S. PATENT DOCUMENTS**

D. 191,276	9/1961	Jucha et al. ....	D12/217
D. 333,687	3/1993	Smith .....	D6/552
2,773,564	12/1956	Garard, Sr. ....	188/32
2,797,774	7/1957	Eckhart .....	188/32
5,464,814	11/1995	Ziaylek .....	188/32

*Primary Examiner*—Robert M. Spear  
*Attorney, Agent, or Firm*—Dorr, Carson, Sloan & Birney, P.C.

[57] **CLAIM**

The ornamental design for a cleat for a wheel chock, as shown and described.

**DESCRIPTION**

FIG. 1 is a bottom perspective view of a cleat for a wheel chock showing my new design;

FIG. 2 is an enlarged bottom plan view;

FIG. 3 is an enlarged left side elevational view taken in the direction of lines 3—3 in FIG. 2, with the right side elevational view being a mirror image of FIG. 3; and,

FIG. 4 is an enlarged rear elevational view taken in the direction of lines 4—4 in FIG. 2, with the front elevational view being the same as FIG. 4.

The broken line showing of wheel chock is for illustrative purposes only and forms no part of the claimed design.

**1 Claim, 4 Drawing Sheets**

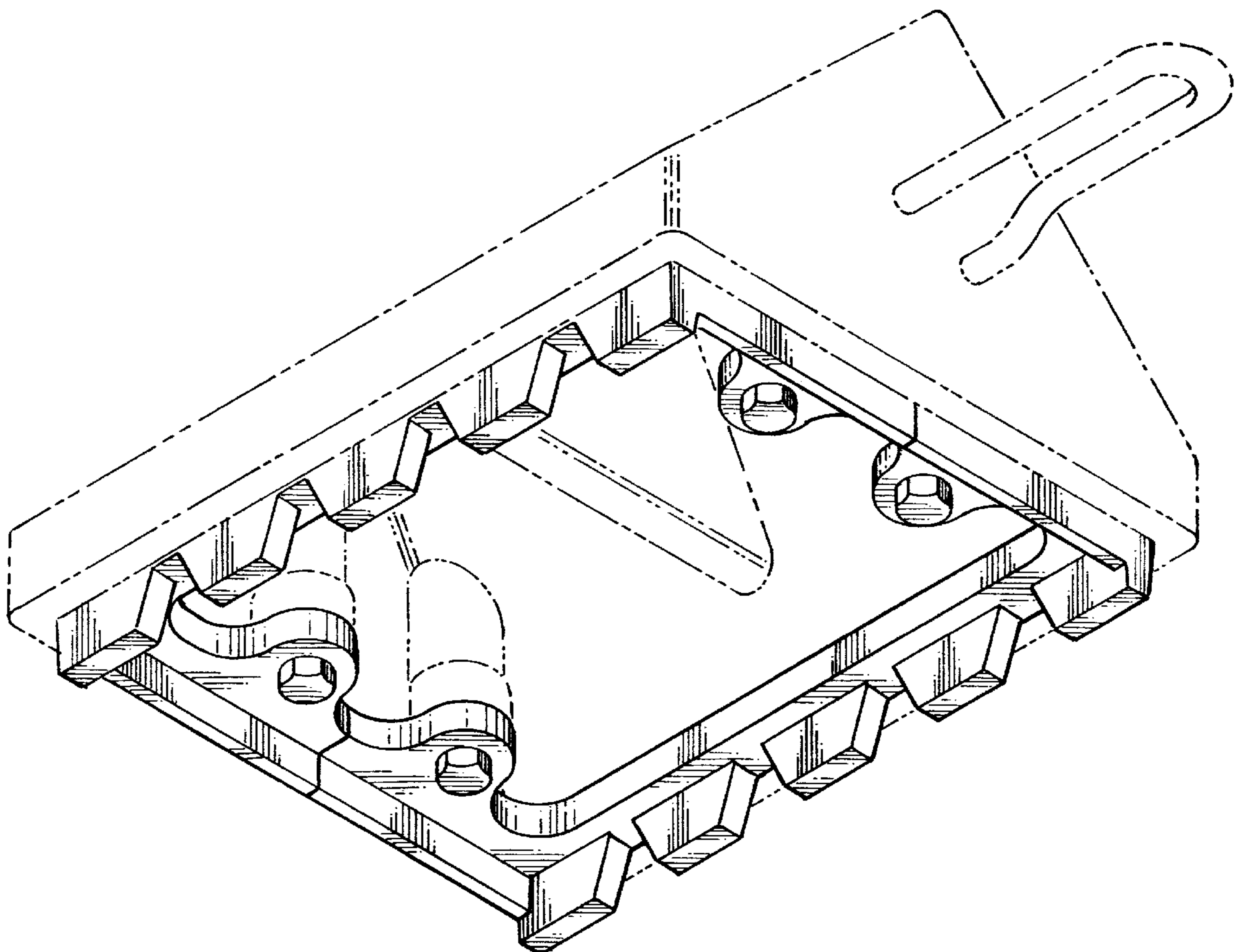

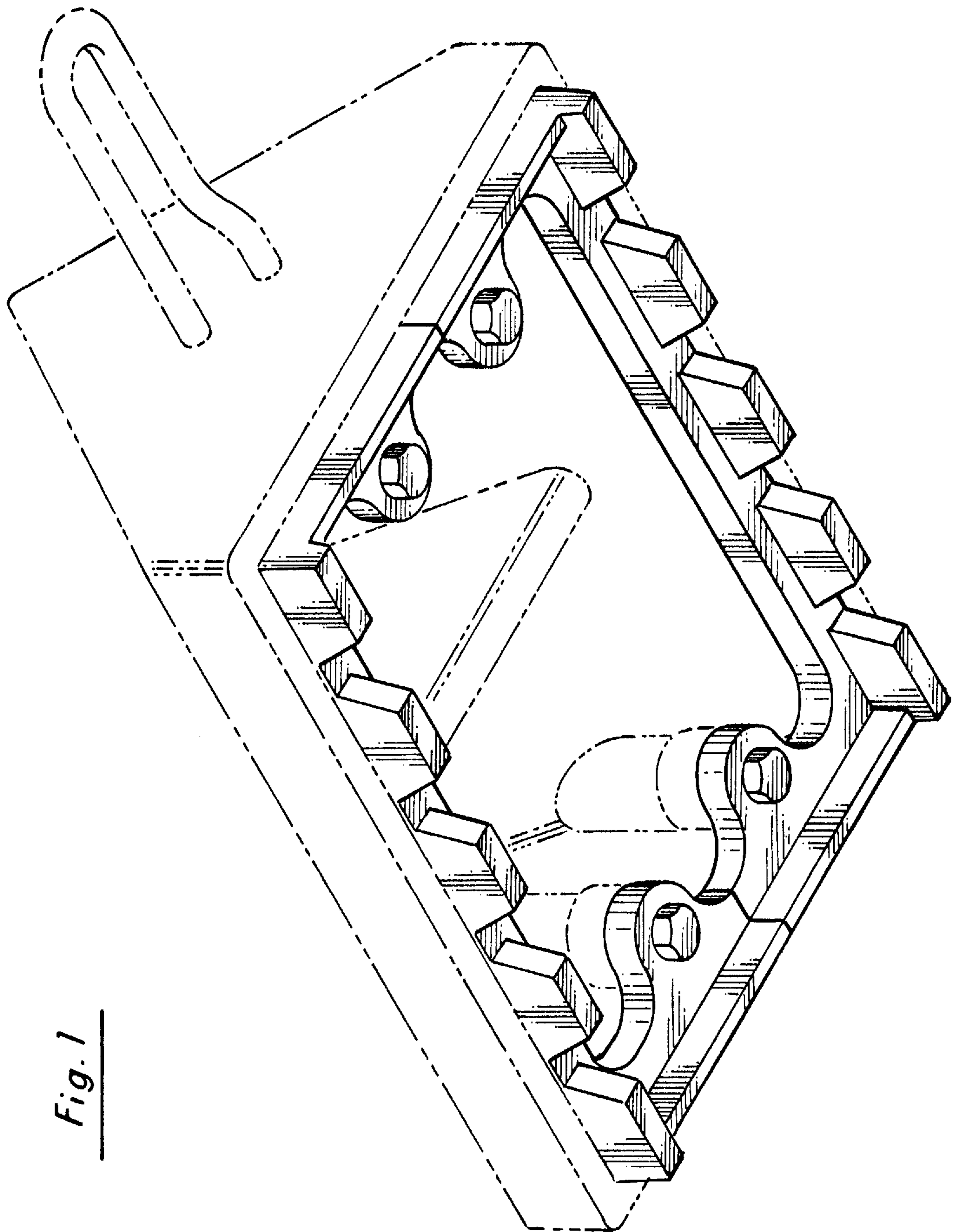
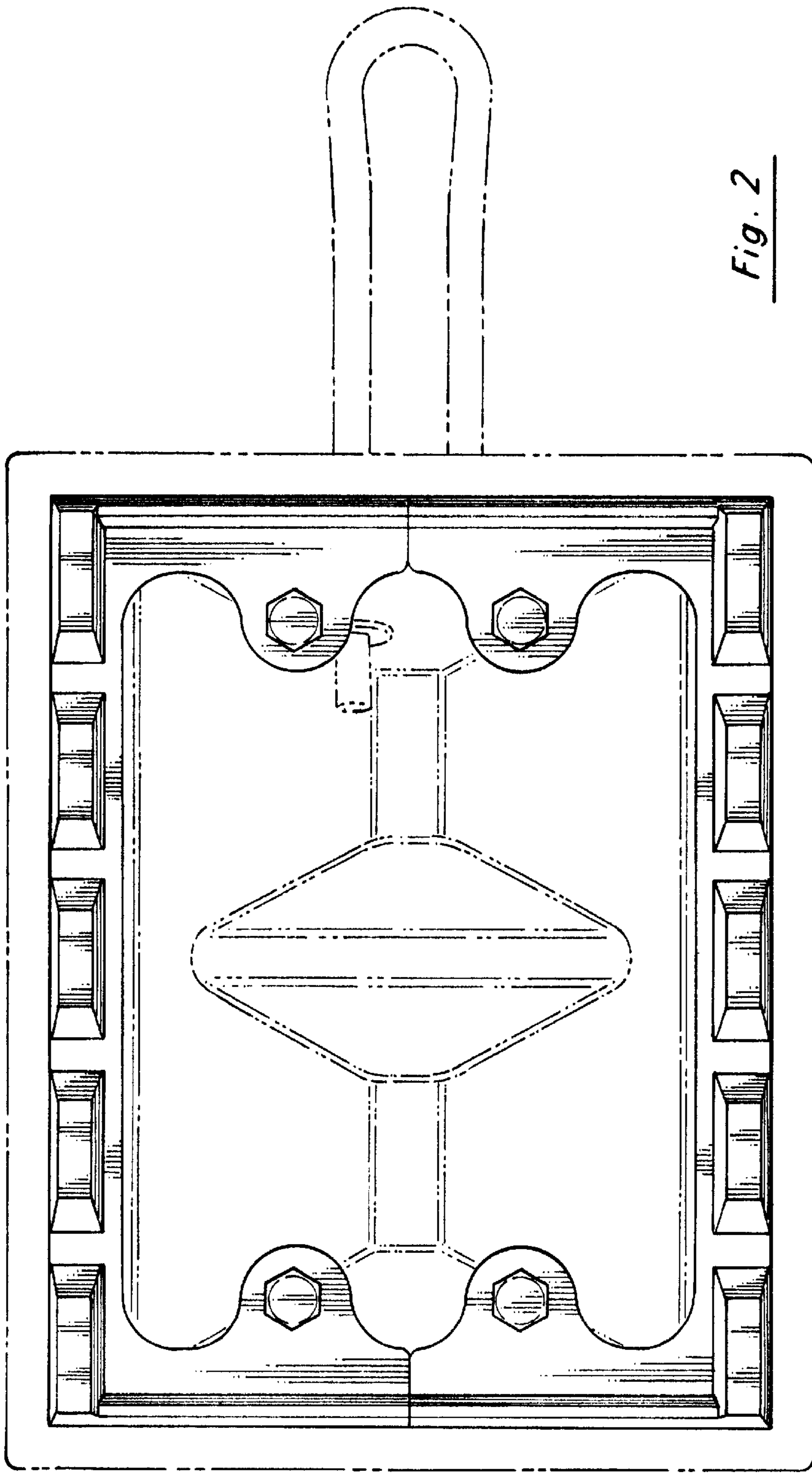
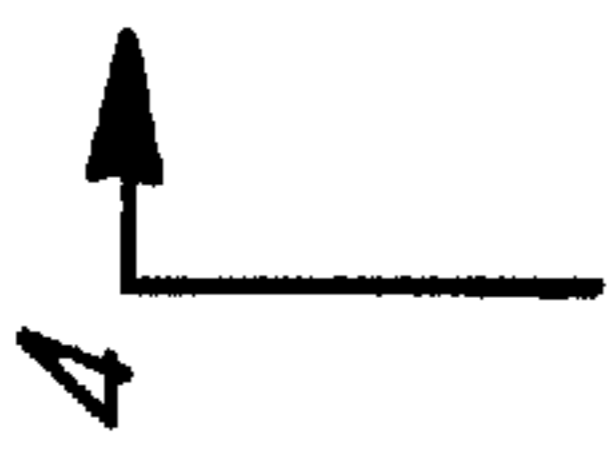
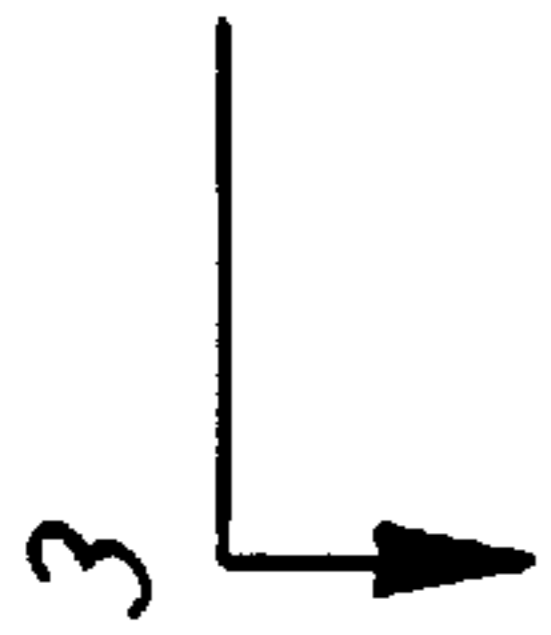
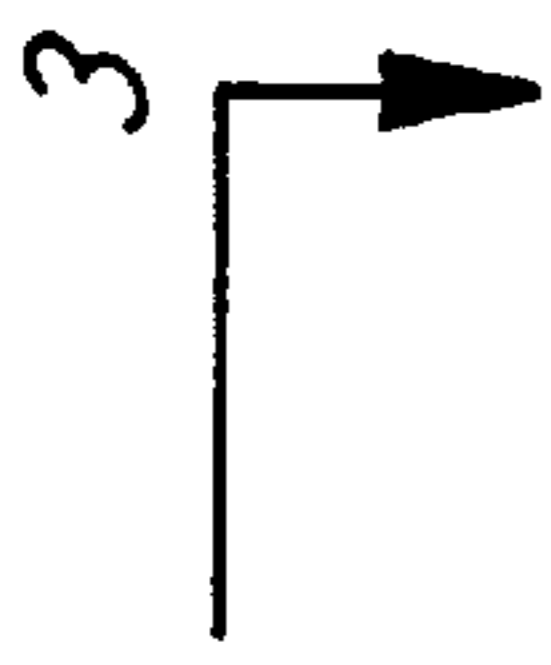

Fig. 1



*Fig. 2*

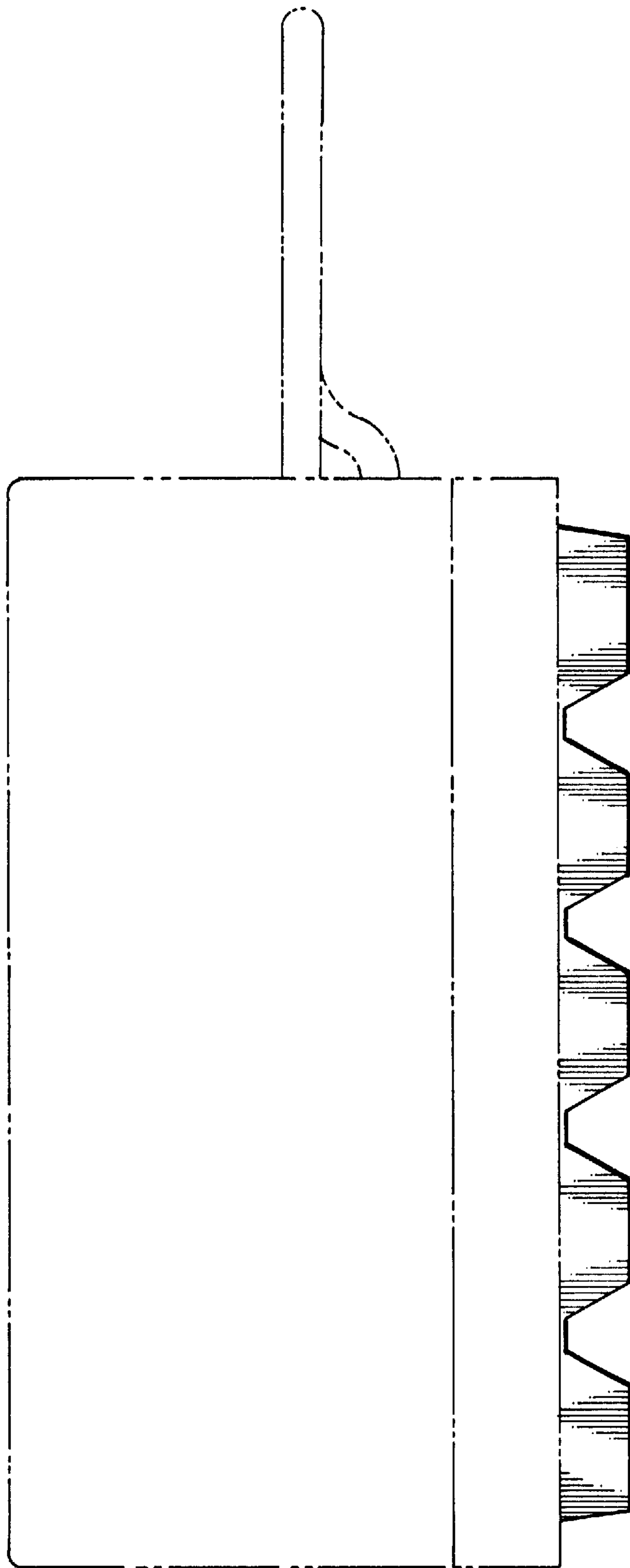

Fig. 3

Fig. 4

