



US00D397829S

United States Patent [19] Gray

[11] Patent Number: **Des. 397,829**
[45] Date of Patent: ****Sep. 1, 1998**

[54] SAFETY RAZOR
[75] Inventor: **Michael J. Gray, Duxbury, Mass.**
[73] Assignee: **The Gillette Company, Boston, Mass.**
[**] Term: **14 Years**
[21] Appl. No.: **58,288**
[22] Filed: **May 3, 1996**

D. 305,805 1/1990 Gray D28/46
D. 309,355 7/1990 Shurtleff D28/48
D. 319,893 9/1991 Pittaway D28/48
D. 325,689 4/1992 Gray D28/48
D. 345,232 3/1994 Gray D28/46
D. 345,821 4/1994 Wonderley D28/48
D. 354,586 1/1995 Grange D28/46
D. 355,049 1/1995 Yasui D28/48
5,027,511 7/1991 Miller 30/526

Related U.S. Application Data

[62] Division of Ser. No. 45,614, Oct. 25, 1995.
[51] LOC (6) Cl. **28-03**
[52] U.S. Cl. **D28/46**
[58] Field of Search D28/46-48; 30/32,
30/34.05, 47-51, 85, 87, 89, 526, 527,
530-533

FOREIGN PATENT DOCUMENTS

130/94 2/1994 Sweden .
190/94 3/1994 Sweden .

Primary Examiner—Ted Shooman
Assistant Examiner—C. Tuttle
Attorney, Agent, or Firm—Charles P. Boukus, Jr.; Edward S. Podszus

[56] References Cited

U.S. PATENT DOCUMENTS

D. 224,481 7/1972 Poisson .
D. 229,876 1/1974 Glaberson D28/46
D. 260,191 8/1981 Chase et al. D28/46
D. 260,944 9/1981 Gray D28/46
D. 261,565 10/1981 Grange D28/48
D. 269,724 7/1983 Chase et al. D28/46
D. 270,384 8/1983 Gray D28/48
D. 271,531 11/1983 Byrne D28/46

[57] CLAIM

The ornamental design for a safety razor, as shown and described.

DESCRIPTION

FIG. 1 is a perspective view of a safety razor showing my new design, as seen from the top, rear and right side;
FIG. 2 is a rear elevational view thereof;
FIG. 3 is a right side elevational view thereof, the opposite left side being a mirror image of the side shown;
FIG. 4 is a front elevational view thereof;
FIG. 5 is a top elevational view thereof; and,
FIG. 6 is a bottom elevational view thereof.

1 Claim, 2 Drawing Sheets

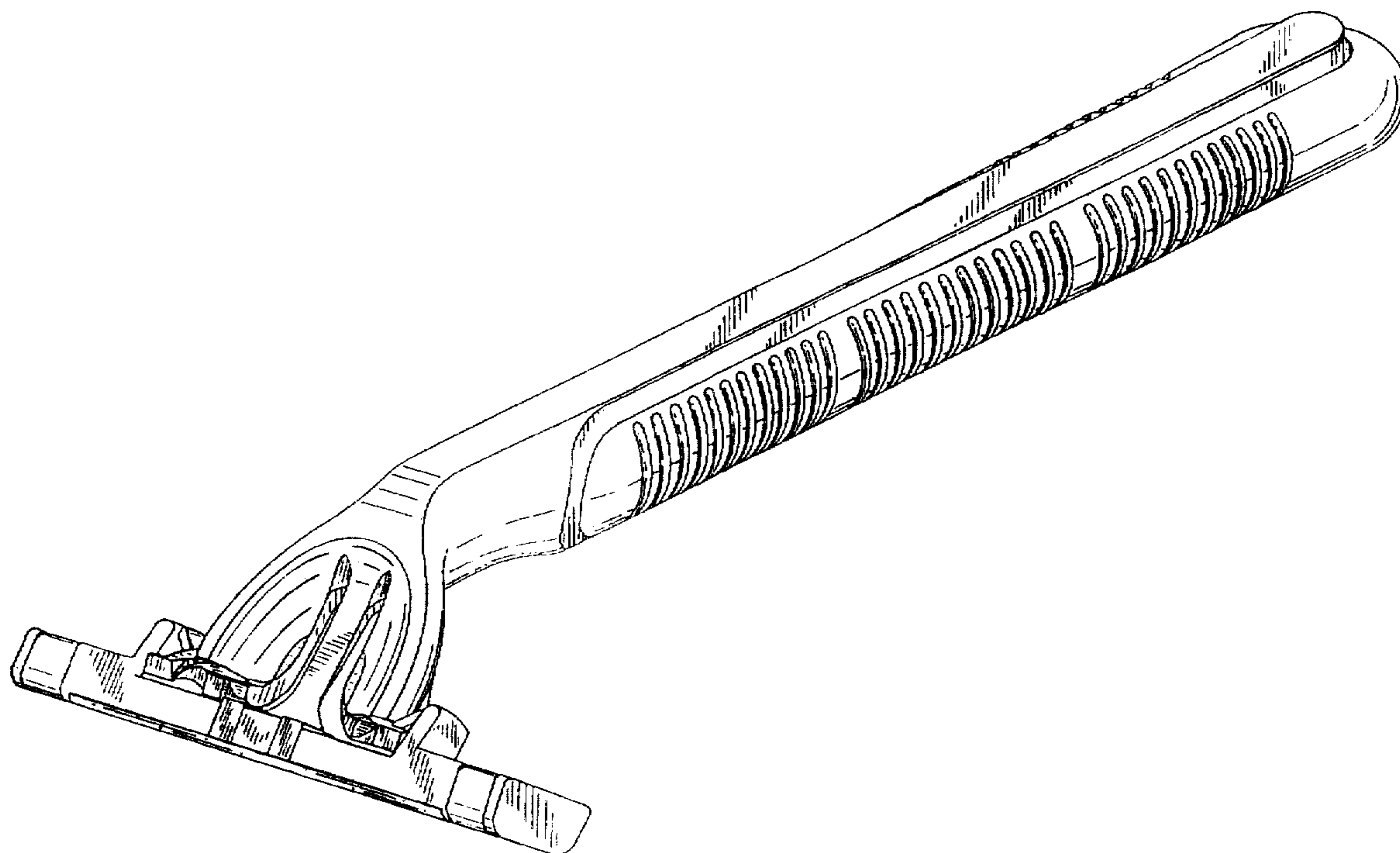

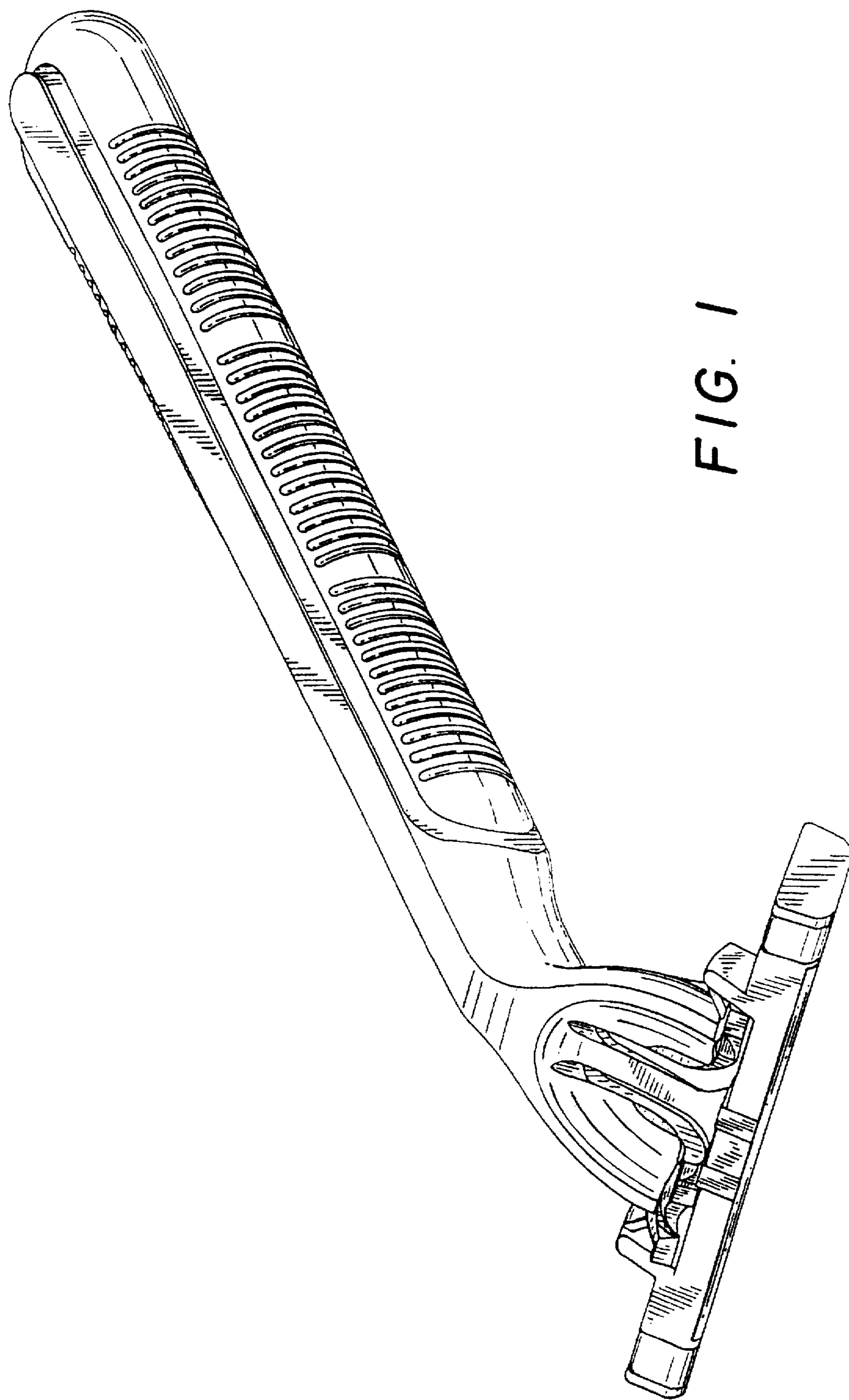

FIG. 1

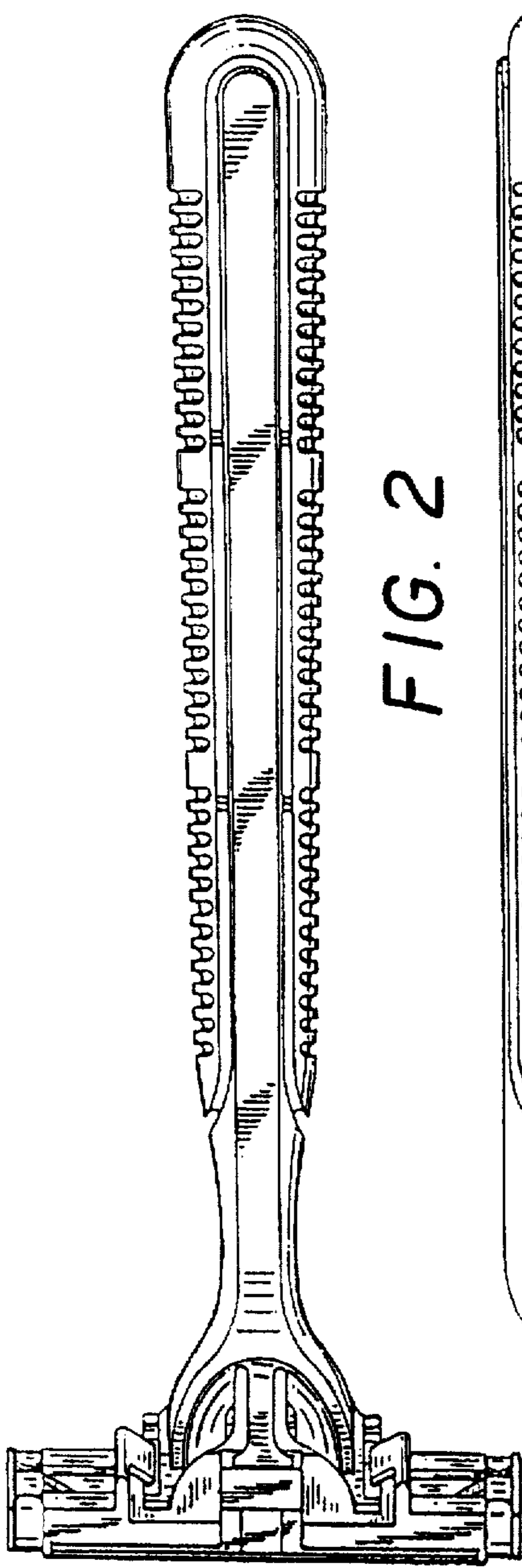

FIG. 2

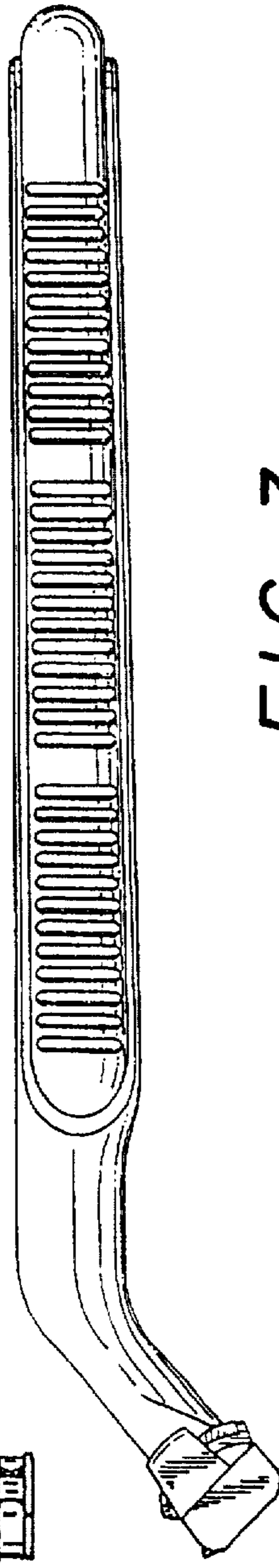

FIG. 3

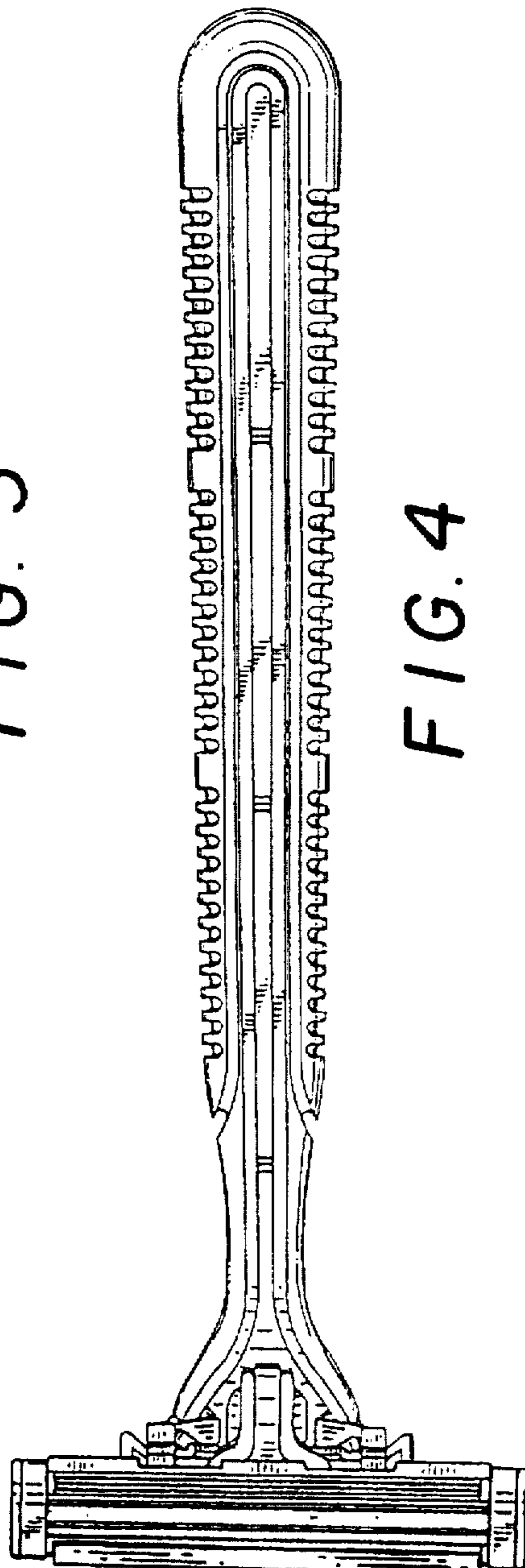

FIG. 4

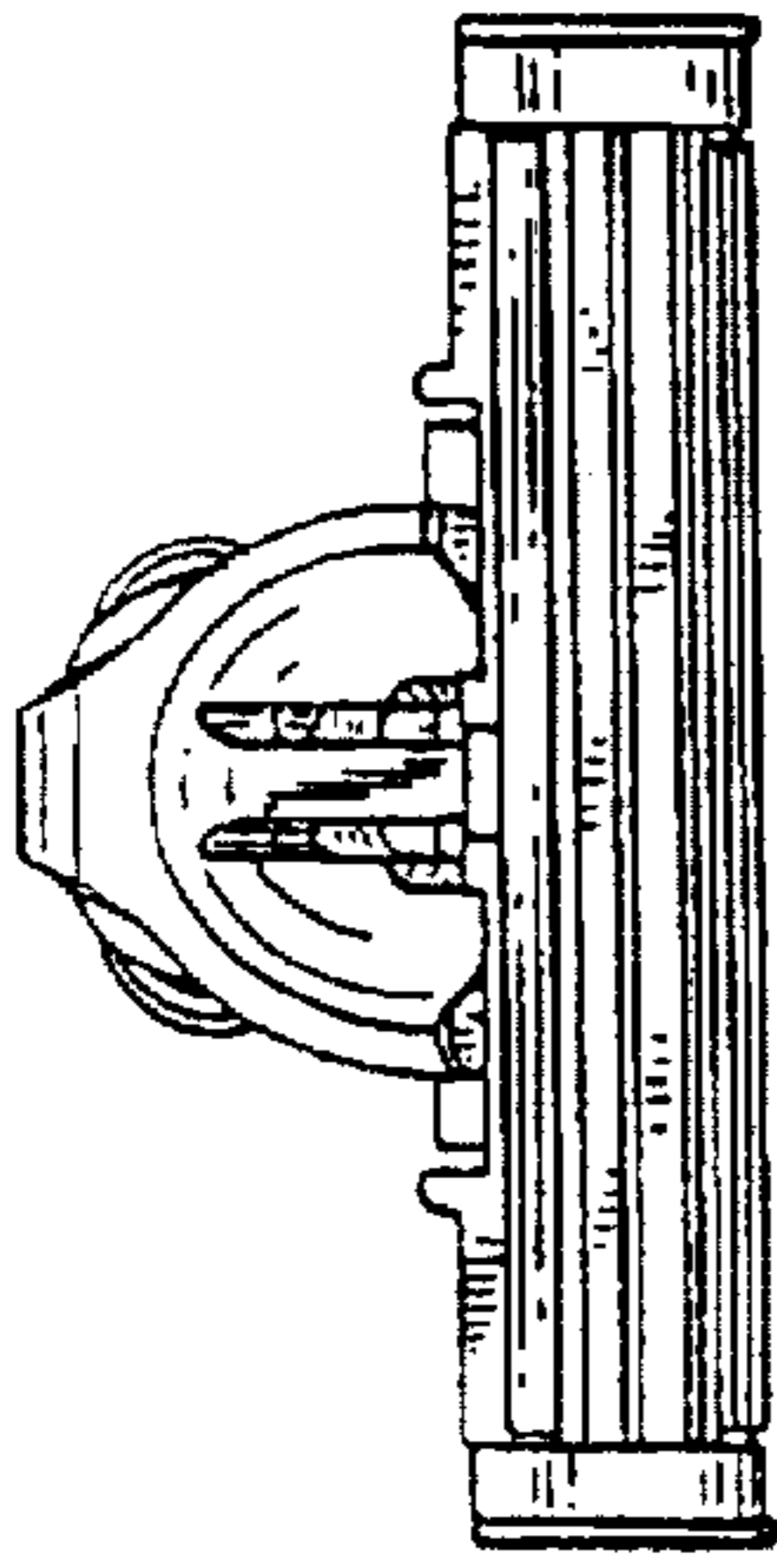

FIG. 5

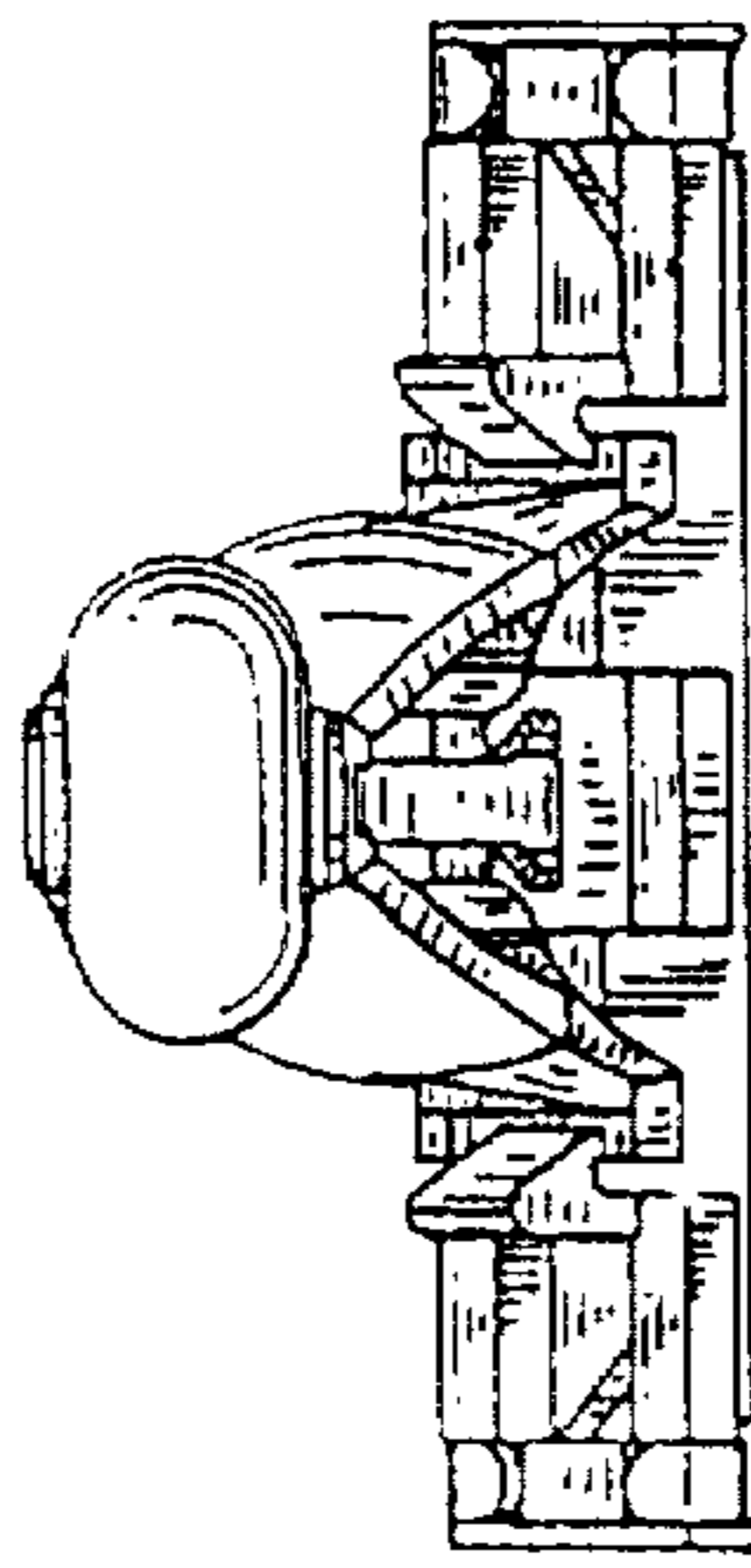

FIG. 6