



US00D397800S

United States Patent [19]

[11] Patent Number: **Des. 397,800**

Acevedo-Arjona et al.

[45] Date of Patent: ****Sep. 1, 1998**

[54] **DRIVE THROUGH ARCHITECTURAL STRUCTURE**

4,147,452	4/1979	Ogasawara et al.	405/134
4,305,683	12/1981	Wagner et al.	405/132
4,906,132	3/1990	Sitz et al.	405/132

[75] Inventors: **Jose Acevedo-Arjona; Guillermo Ibarra-Rey Conde**, both of Celaya, Mexico

Primary Examiner—Doris Clark
Attorney, Agent, or Firm—Ladas & Parry

[73] Assignee: **Publilatas, A. De C.V.**, Celaya, Mexico

[57] **CLAIM**

[**] Term: **14 Years**

The ornamental design for a drive through architectural structure, as shown and described.

[21] Appl. No.: **63,628**

DESCRIPTION

[22] Filed: **Dec. 11, 1996**

FIG. 1 is a perspective view, with one of the doors in open position, the broken lines of a car and roadway are for illustrative purposes only and forms no part of the claimed design;

[51] LOC (6) Cl. **25-03**

[52] U.S. Cl. **D25/18**

[58] Field of Search D25/18; 405/132, 405/133, 134, 138, 143

FIG. 2 is a right side view thereof;
FIG. 3 is a left side view thereof;
FIG. 4 is a top view thereof;
FIG. 5 is a front view thereof; and,
FIG. 6 is a rear view thereof.

[56] References Cited

U.S. PATENT DOCUMENTS

D. 257,570 11/1980 Wollin D25/18

1 Claim, 4 Drawing Sheets

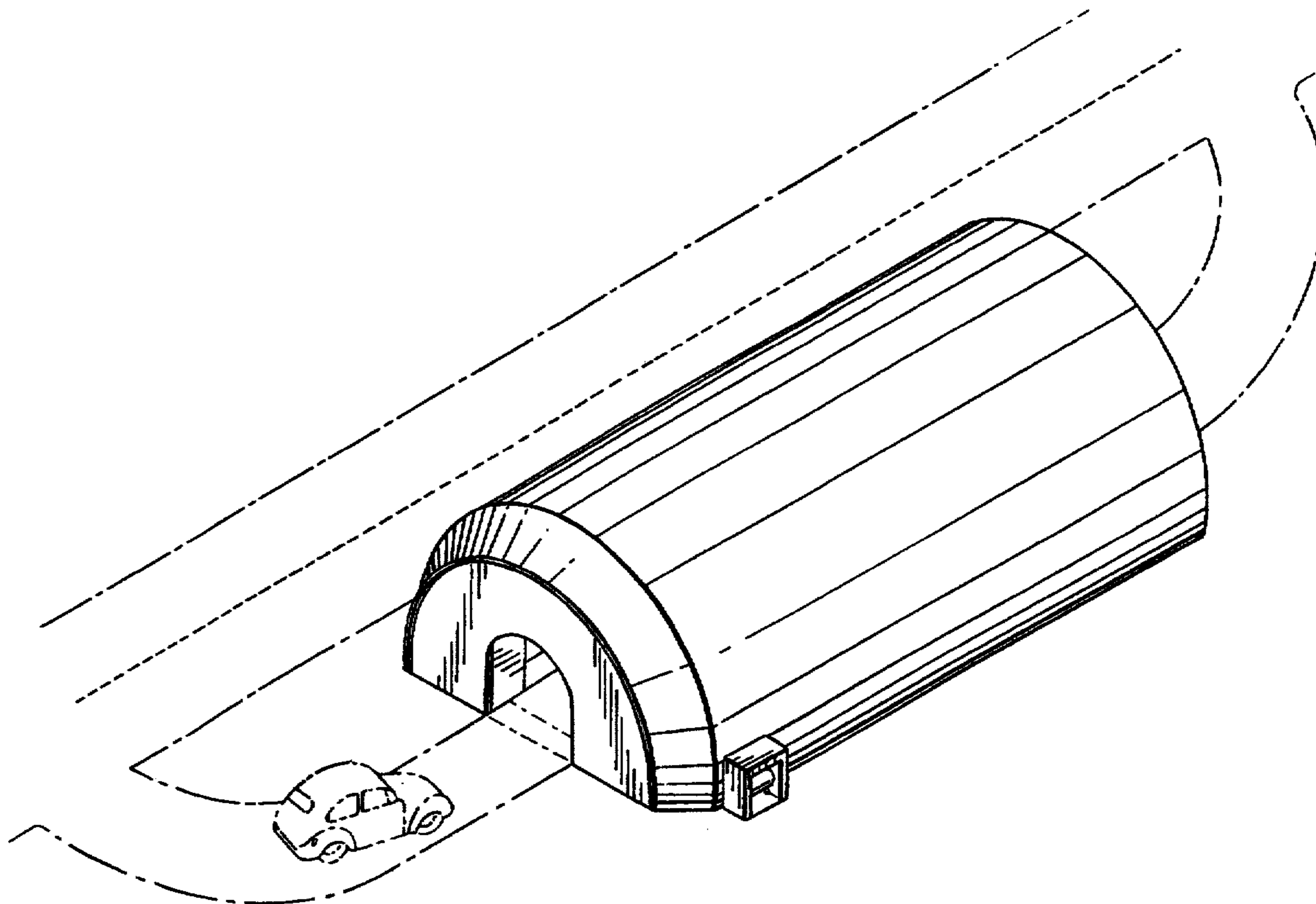

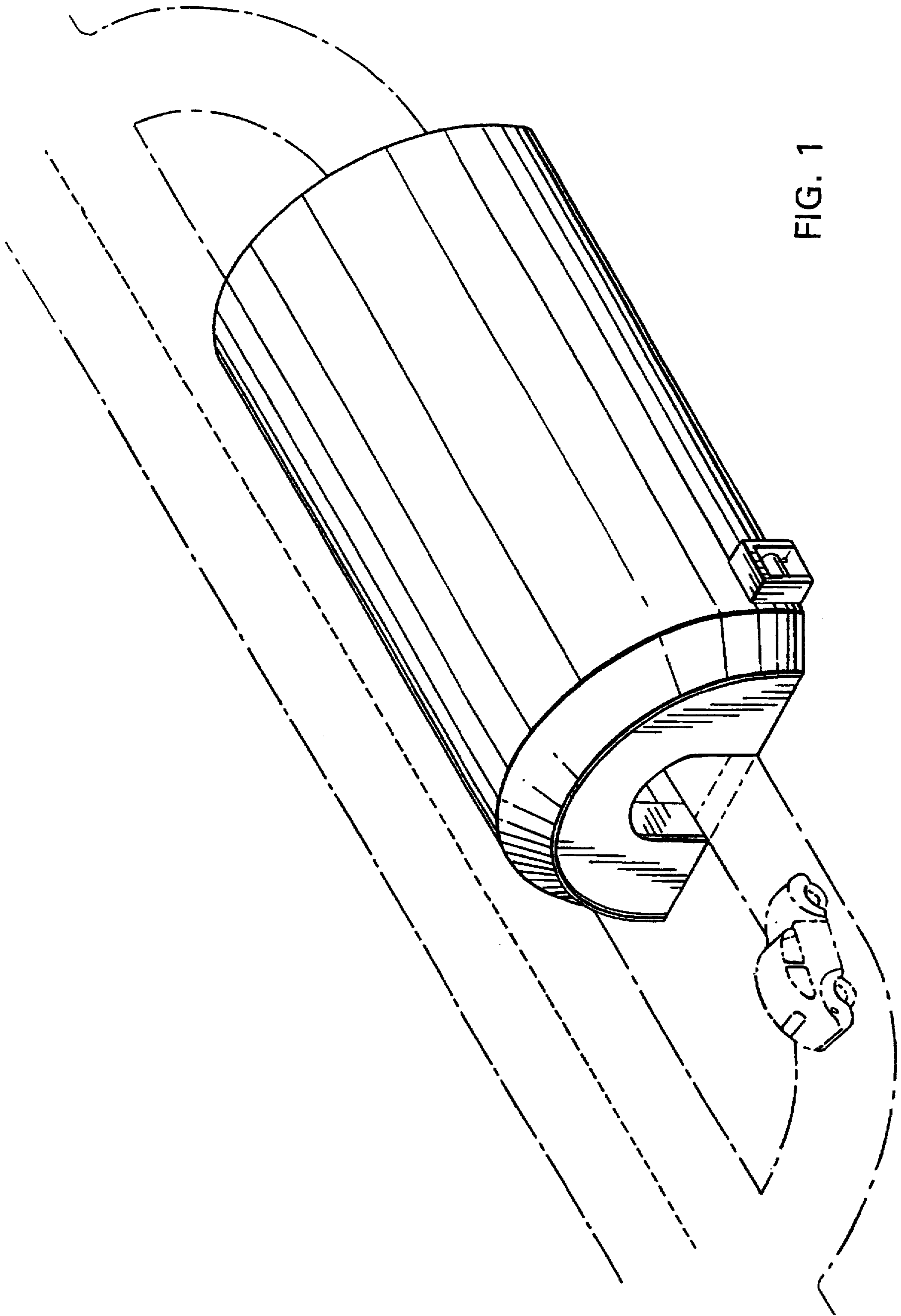

FIG. 1

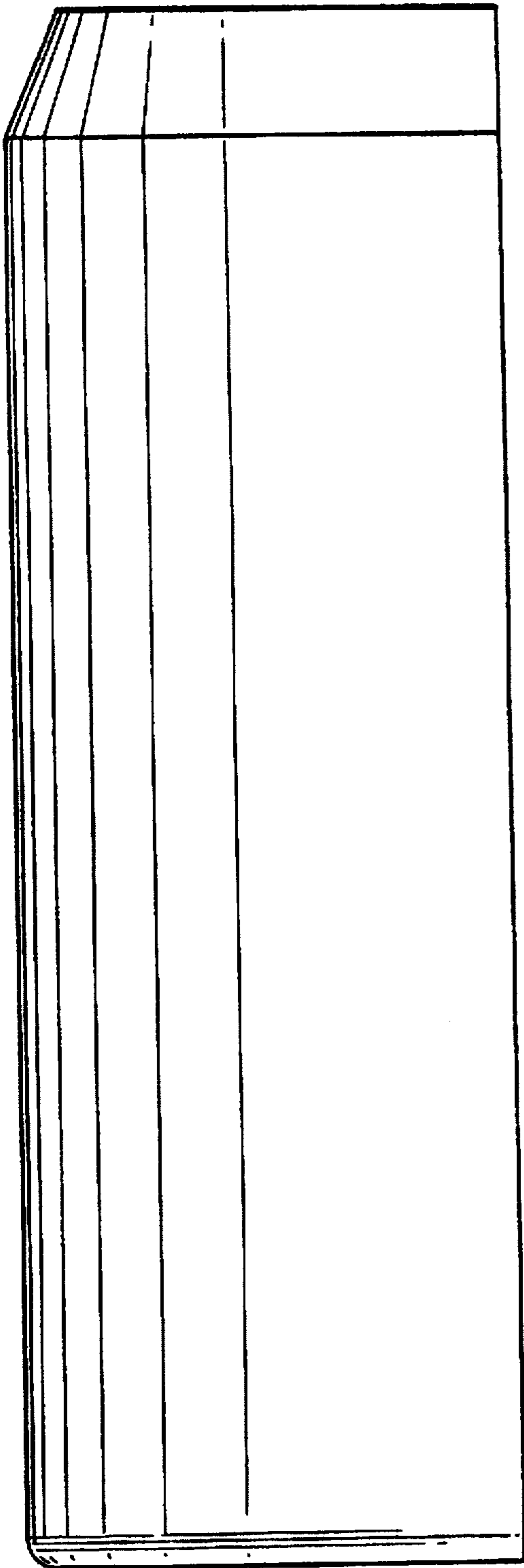

FIG. 2

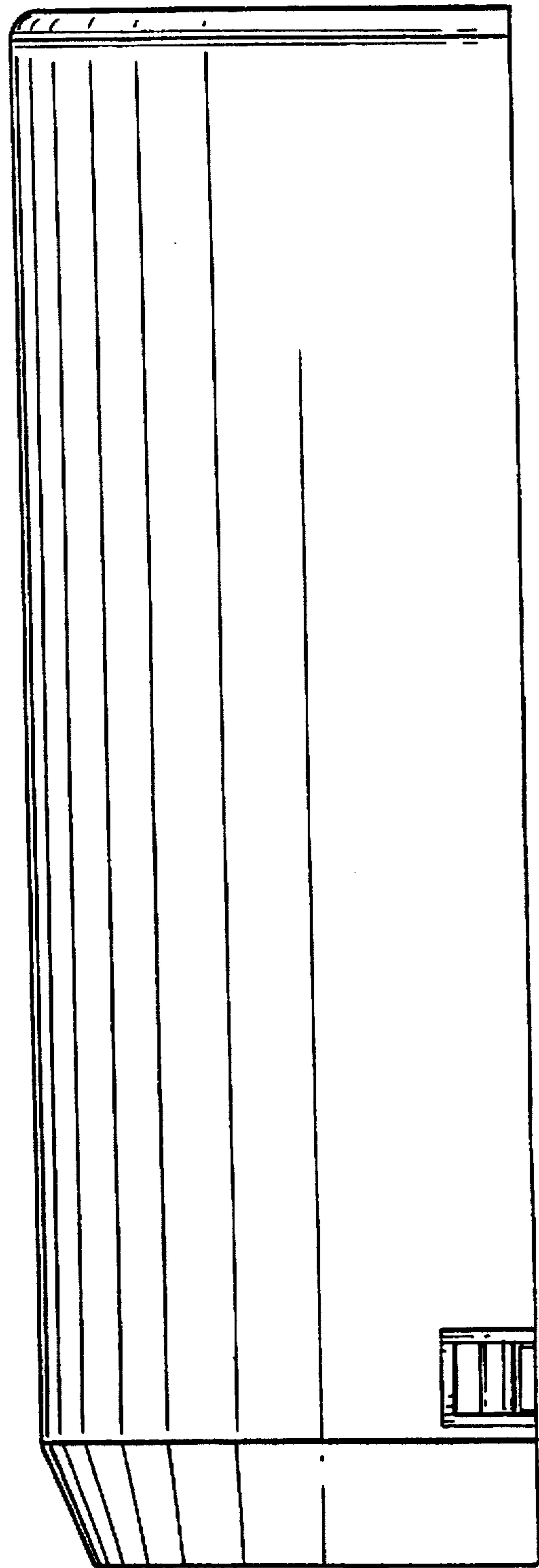

FIG. 3

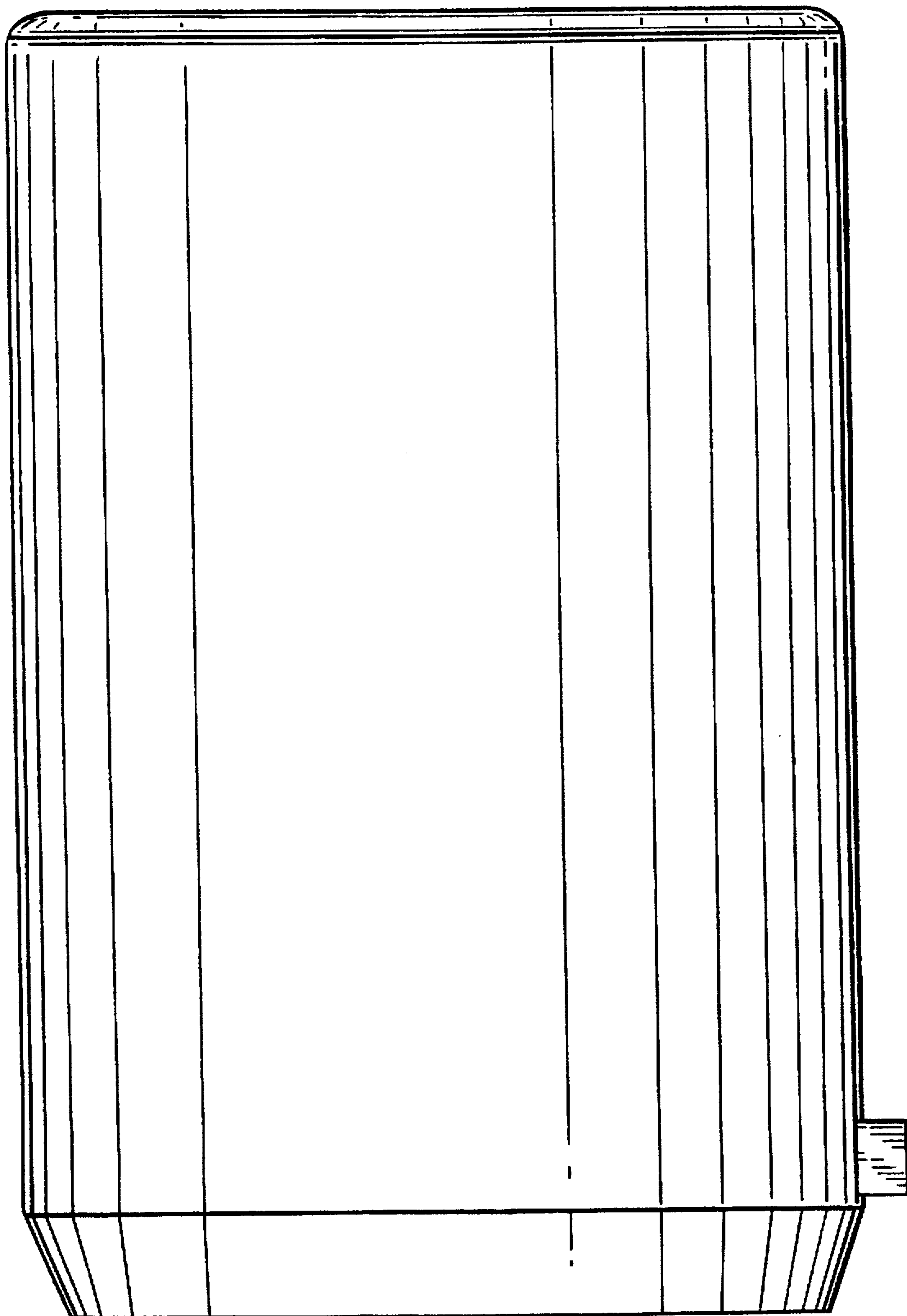

FIG. 4

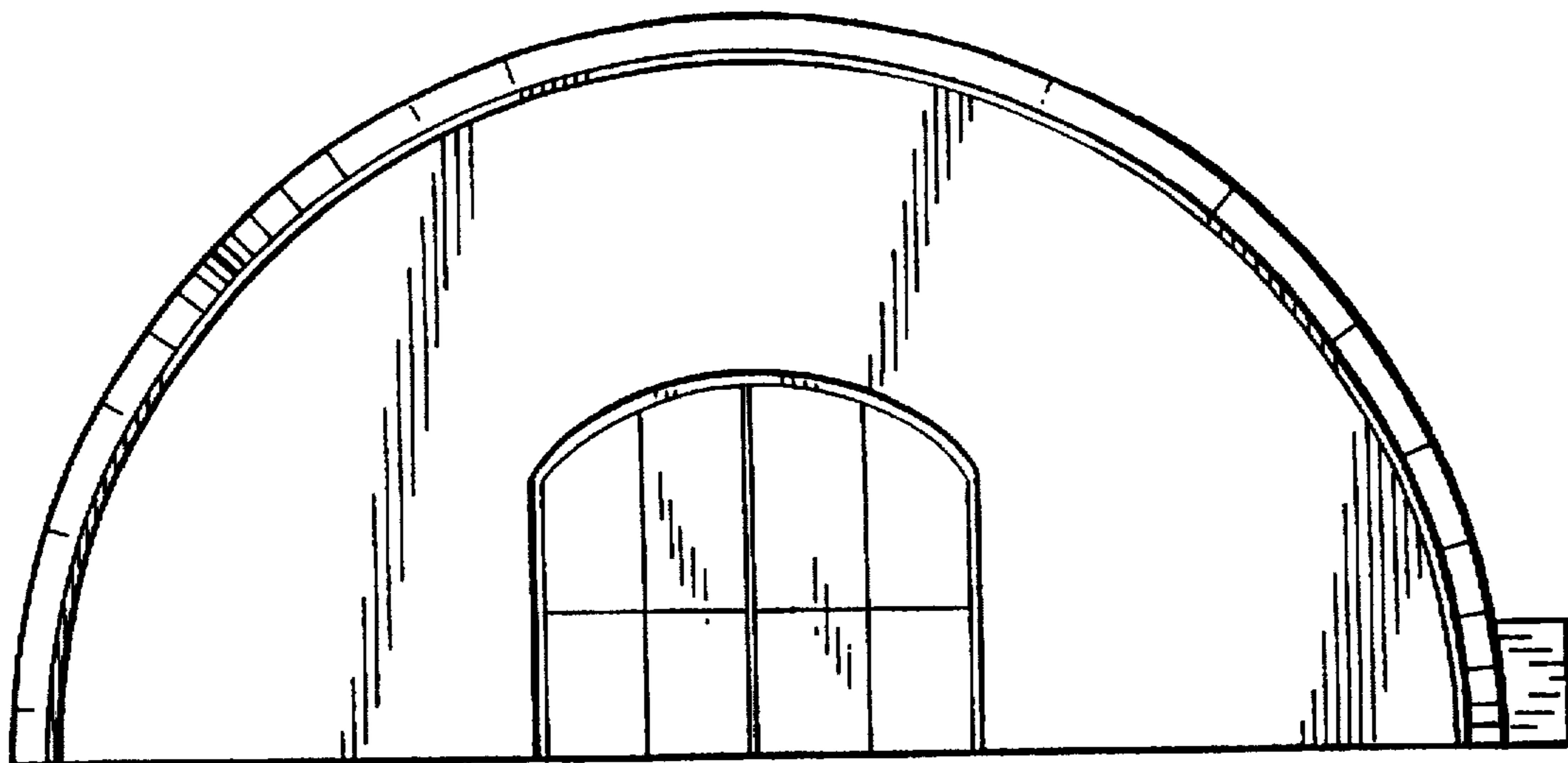

FIG. 5

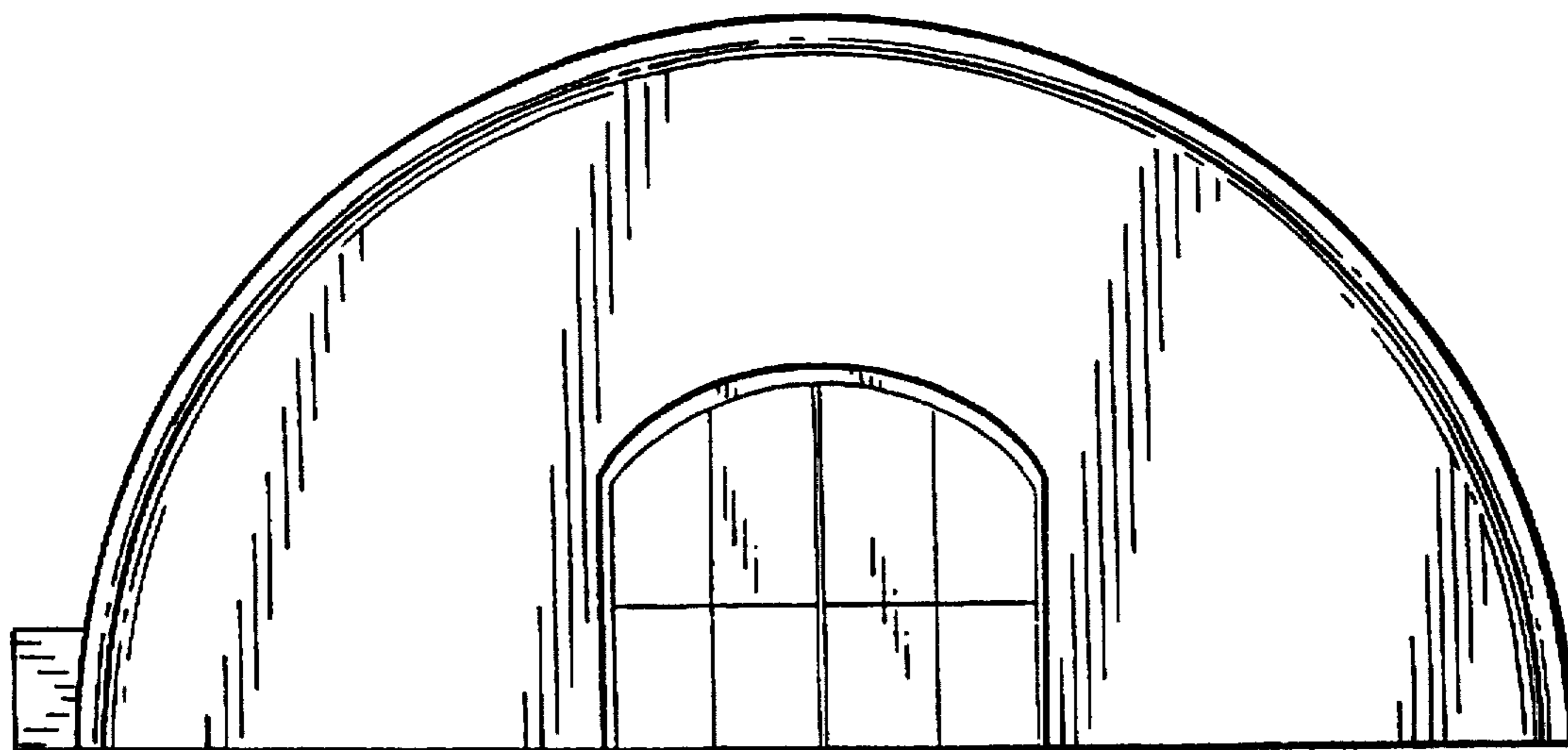

FIG. 6