



US00D397739S

United States Patent [19]

Liu

[11] Patent Number: **Des. 397,739**

[45] Date of Patent: ****Sep. 1, 1998**

[54] **POLICE CYCLE**

[76] Inventor: **Pao-Yu Liu**, 6F., 218, Tatung Rd., Sec. 3, Shichi Chen, Taipei Hsien, Taiwan

[**] Term: **14 Years**

[21] Appl. No.: **68,279**

[22] Filed: **Mar. 25, 1997**

[51] LOC (6) Cl. **21-01**

[52] U.S. Cl. **D21/80**

[58] Field of Search D21/71-81, 128, D21/129, 131, 132, 134, 136, 137, 140, 141; D12/112, 87, 91, 92, 110; 446/424, 425, 427, 433, 454, 456, 457, 462, 465, 470, 440; 280/87.01, 87.021, 1.13, 828, 47.11; 180/210

[56] **References Cited**

U.S. PATENT DOCUMENTS

- D. 244,101 4/1977 Goldberg D21/76
- D. 276,251 11/1984 Wakimura D21/134
- D. 279,913 7/1985 Matsushiro D21/80
- D. 289,272 4/1987 Phinney D12/112

- D. 300,619 4/1989 Phinney et al. D12/112
- D. 307,610 5/1990 Harrod D21/80
- D. 327,512 6/1992 Harrod D21/76
- 3,333,862 8/1967 Rockwell 280/87.021
- 3,798,832 3/1974 Terzian 446/440
- 4,484,649 11/1984 Kennedy et al. 446/457

Primary Examiner—Raphael Barkai

Attorney, Agent, or Firm—Pro-Techtor International Services

[57] **CLAIM**

The ornamental design for a police cycle substantially, as shown and described.

DESCRIPTION

FIG. 1 is a perspective view of the police cycle, showing my design;
 FIG. 2 is a front elevational view thereof;
 FIG. 3 is a left side elevational view thereof;
 FIG. 4 is a right side elevational view thereof;
 FIG. 5 is a top plan view thereof;
 FIG. 6 is a bottom plan view thereof; and,
 FIG. 7 is a rear elevational view thereof.

1 Claim, 4 Drawing Sheets

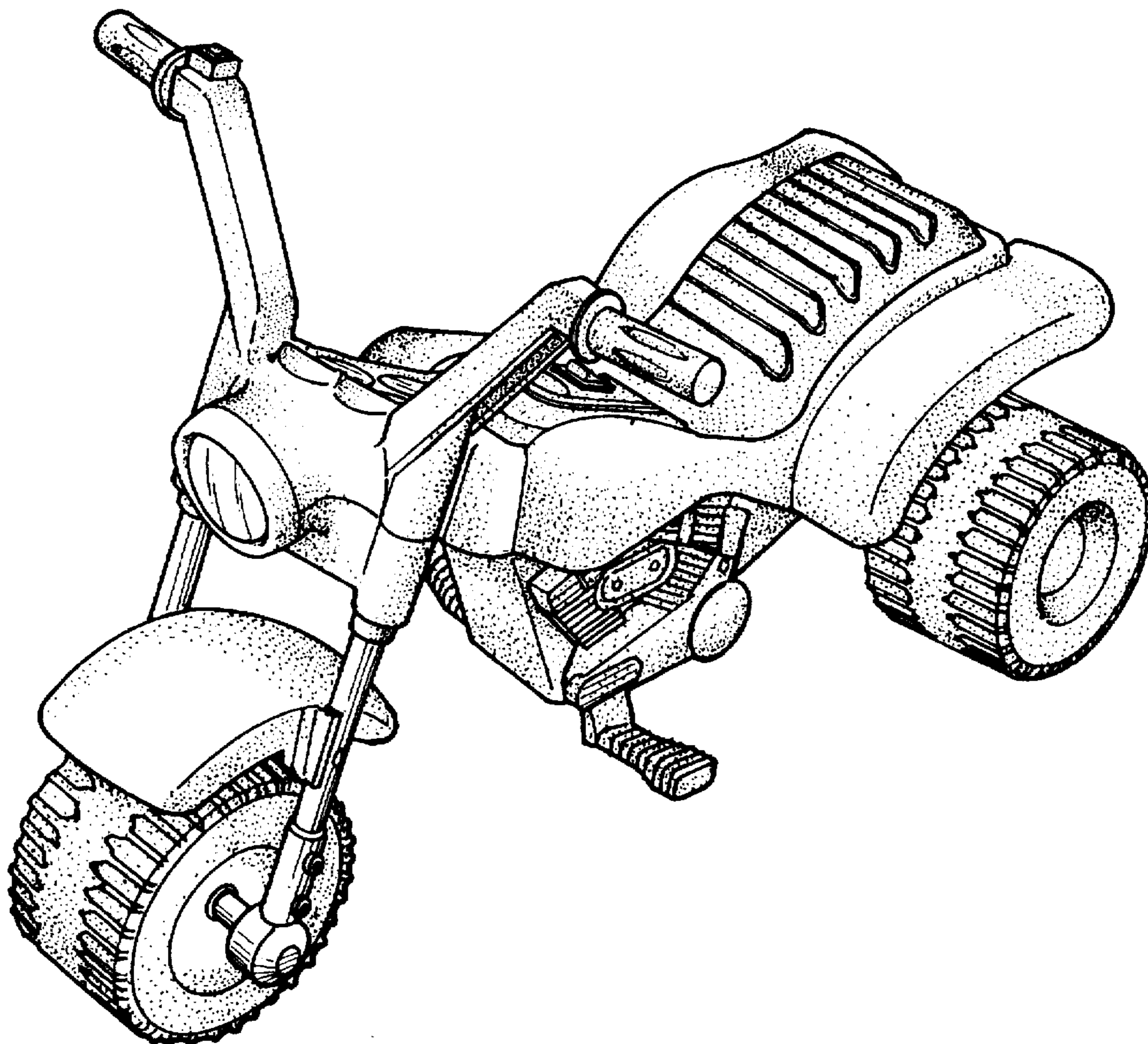

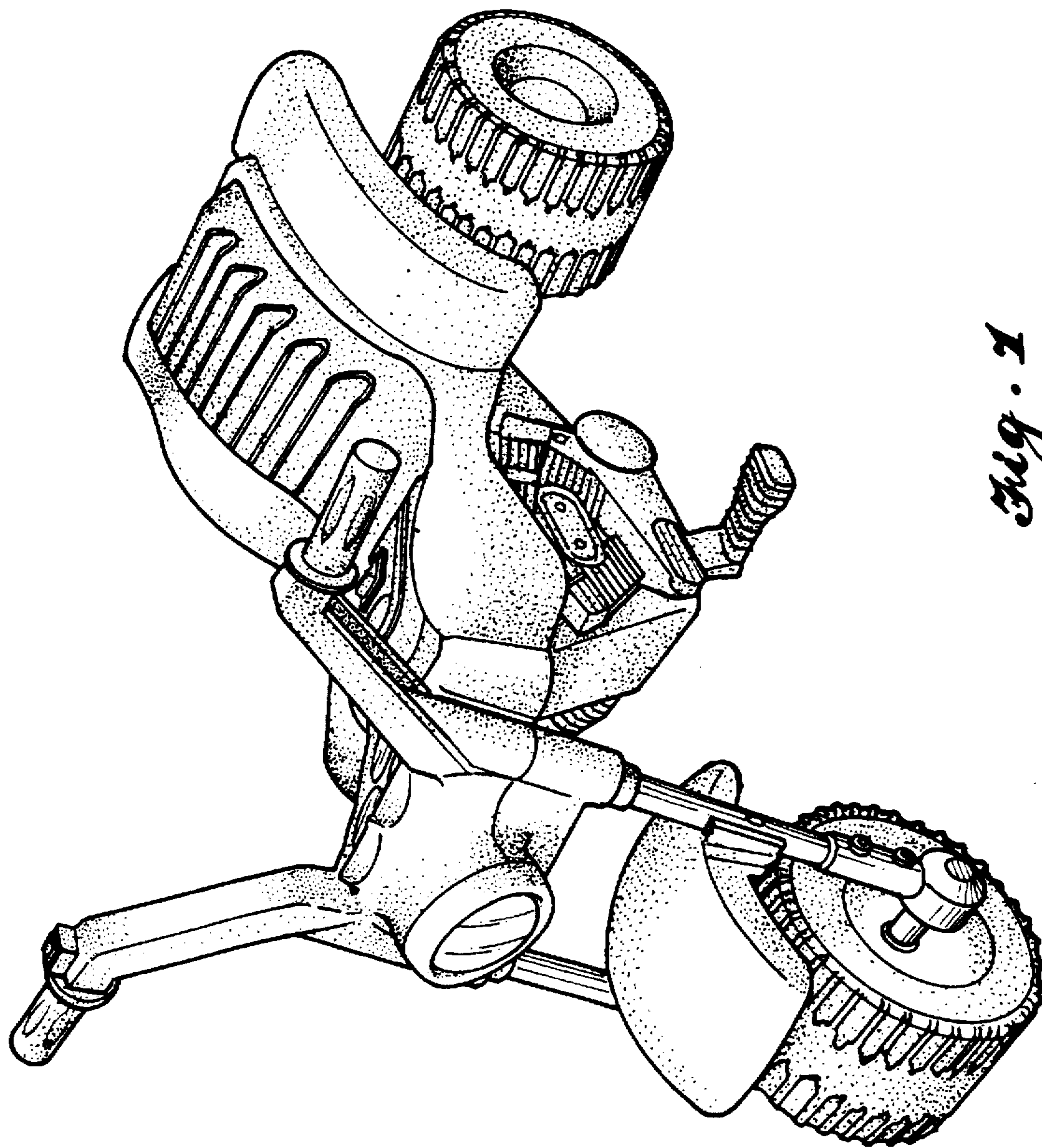

Fig. 1

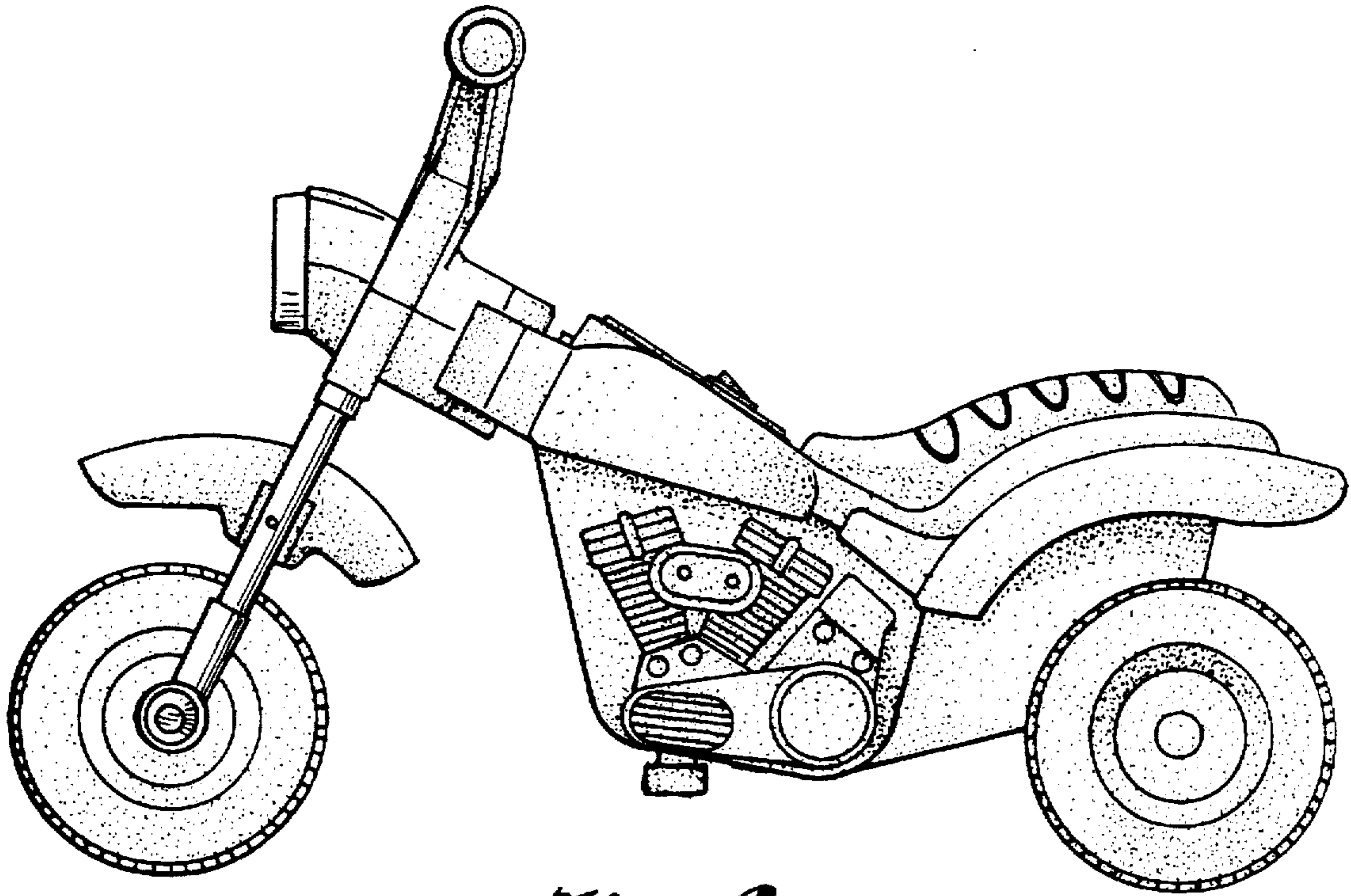

Fig. 2

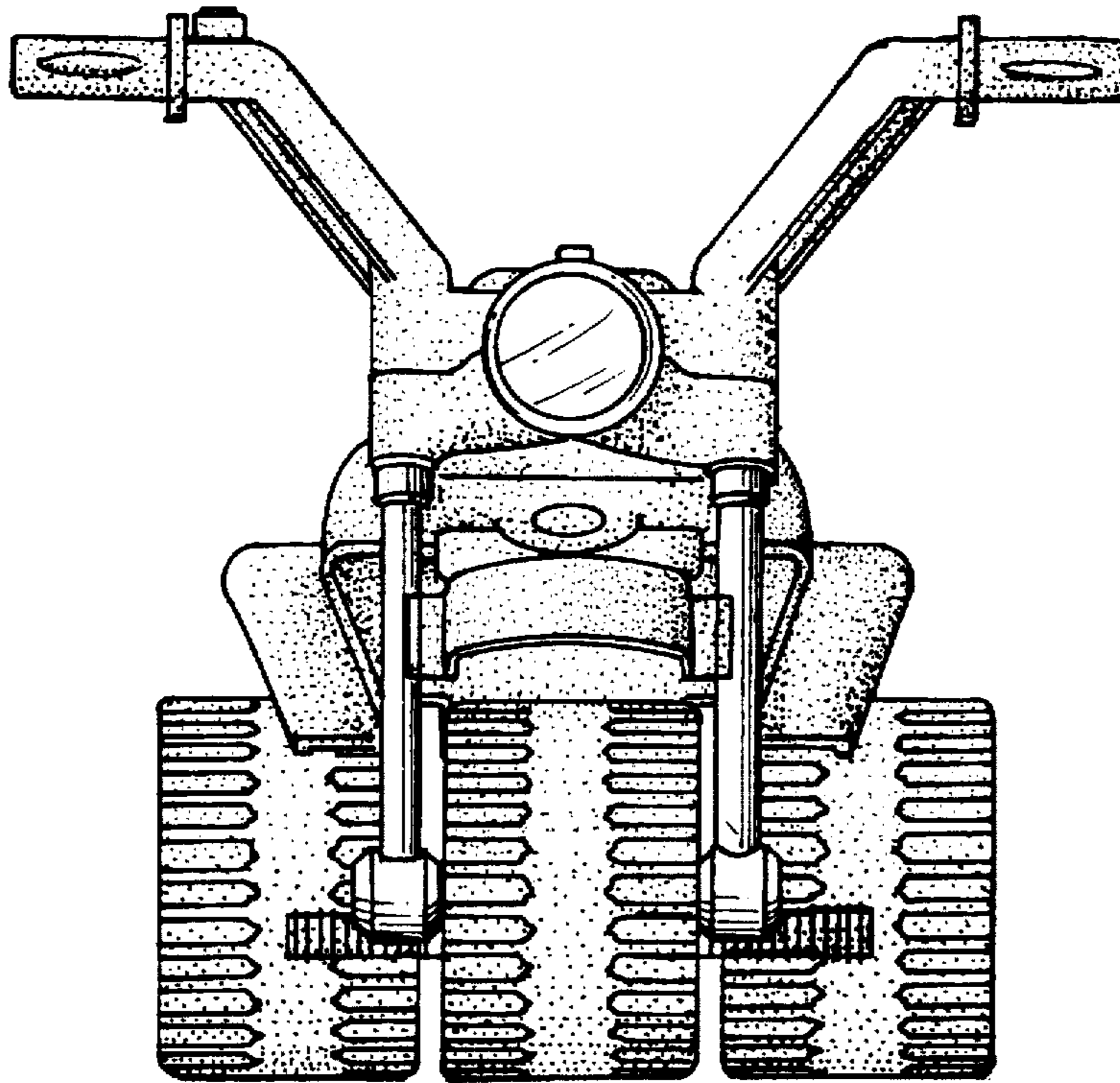

Fig. 3

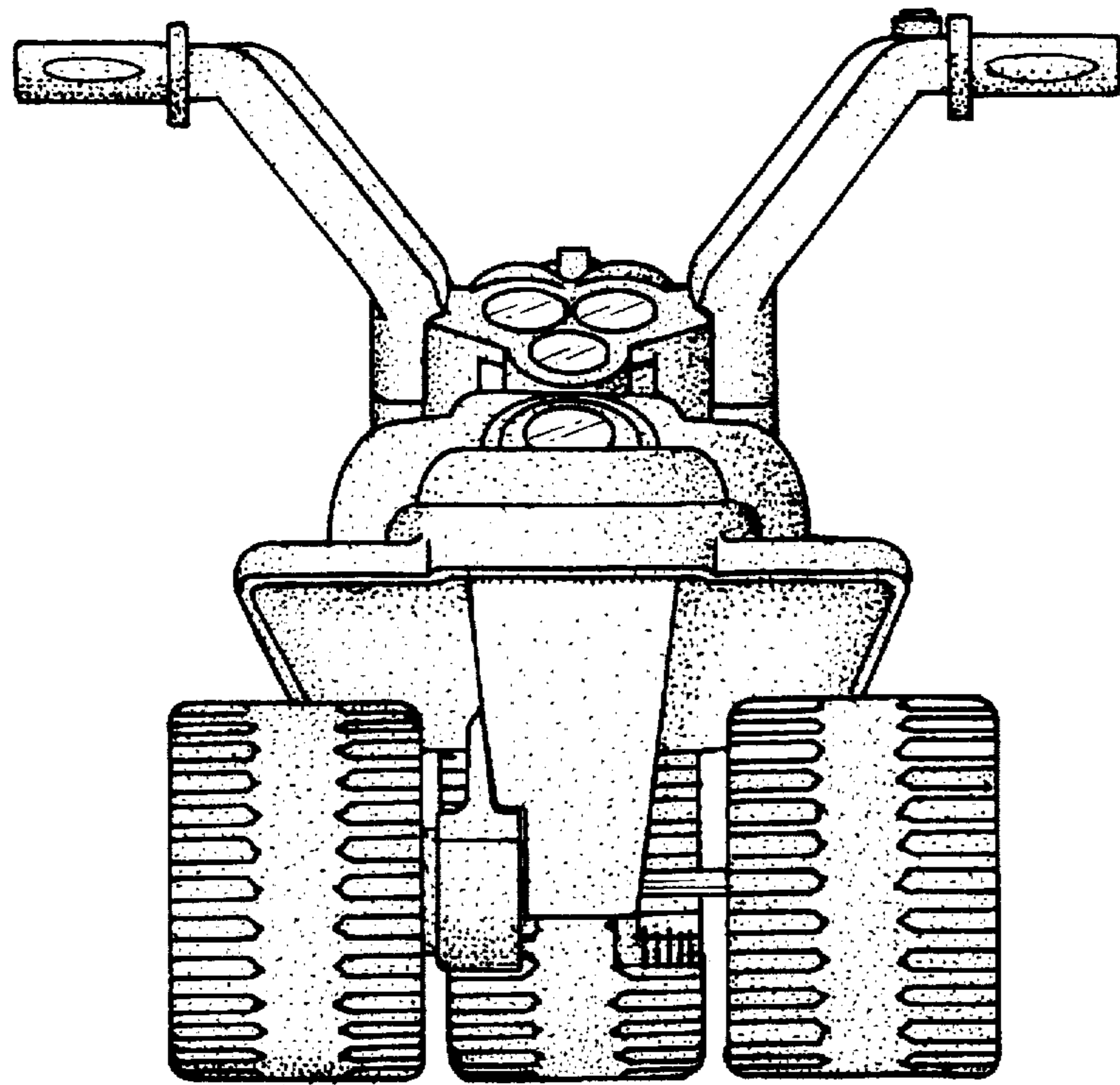

Fig. 4

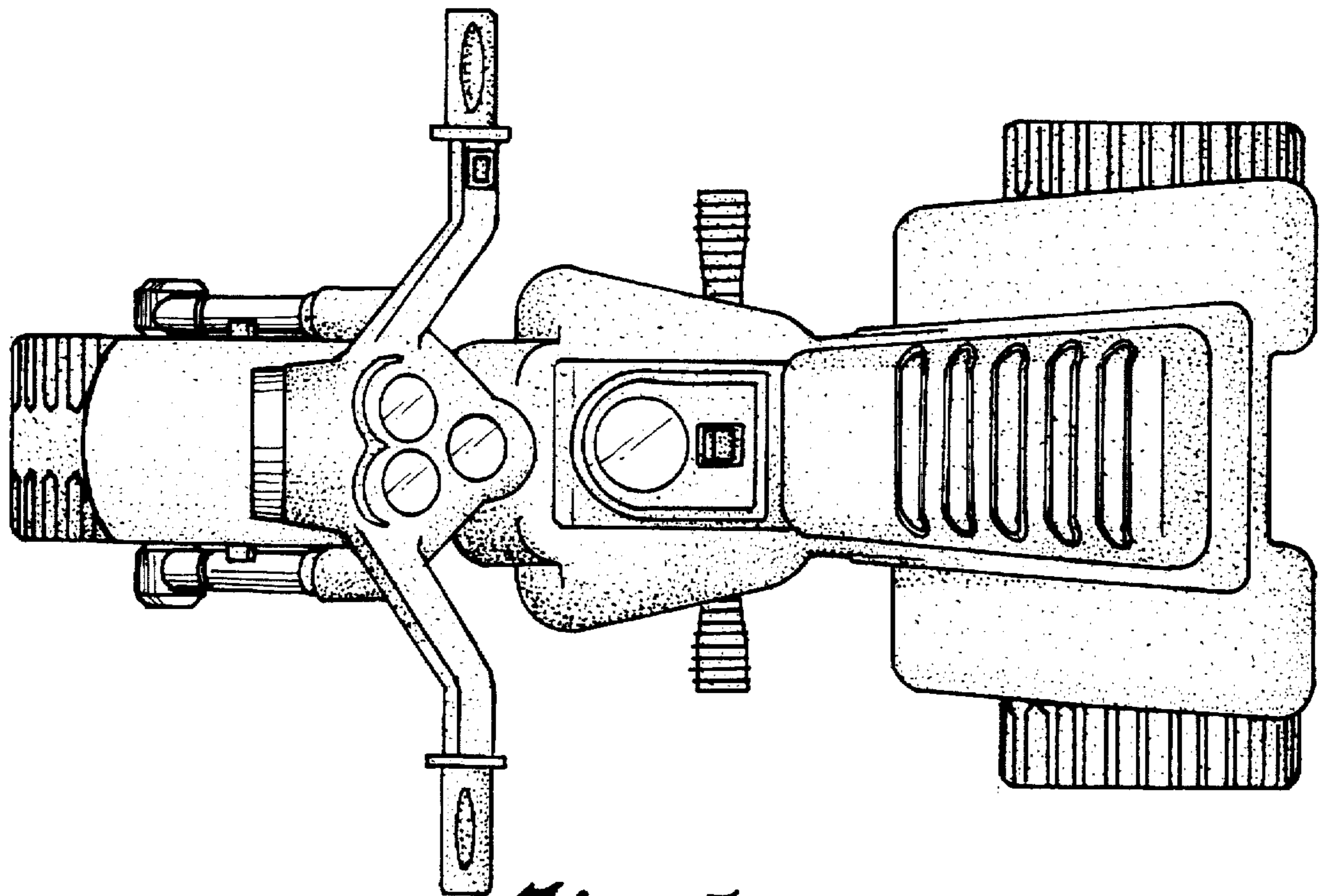

Fig. 5

