



US00D397669S

**United States Patent** [19]  
**Komick**

[11] **Patent Number: Des. 397,669**  
[45] **Date of Patent: \*\*Sep. 1, 1998**

[54] **TENT FOR PICK-UP TRUCK**  
[76] **Inventor: Dennis R. Komick, 126 44th St.,  
Manhattan Beach, Calif. 90266**  
[\*\*] **Term: 14 Years**  
[21] **Appl. No.: 61,431**  
[22] **Filed: Oct. 21, 1996**  
[51] **LOC (6) Cl. .... 12-16**  
[52] **U.S. Cl. .... D12/403**  
[58] **Field of Search .... D12/400, 403-404;  
296/164, 159; 135/88.01-88.09; D21/253**

D. 367,463 2/1996 Reiland ..... D12/403  
2,963,030 12/1960 Blanchard ..... 135/88.01  
4,310,194 1/1982 Biller ..... 296/164  
4,332,265 6/1982 Baker ..... 135/88.01  
4,807,924 2/1989 Kottke ..... 296/164  
5,299,849 4/1994 Cook et al. .... 296/164 X

*Primary Examiner*—James Gandy  
*Assistant Examiner*—Stacia Sinuik  
*Attorney, Agent, or Firm*—Cislo & Thomas LLP

[57] **CLAIM**

The ornamental design for a tent for pick-up truck, as described and shown.

**DESCRIPTION**

FIG. 1 is a perspective view of my tent for pick-up truck in association with the hard tonneau and bed of a truck;  
FIG. 2 is a back view thereof;  
FIG. 3 is a front view thereof;  
FIG. 4 is a right side elevational view thereof;  
FIG. 5 is a left side elevational view thereof;  
FIG. 6 is a top view thereof; and,  
FIG. 7 is a bottom view thereof.  
The broken line showing of the pick-up truck in FIG. 1 is for illustrative purposes only and forms no part of the claimed design and the broken lines shown on the tent in FIGS. 1-6 represent stitching.

[56] **References Cited**  
**U.S. PATENT DOCUMENTS**  
Re. 29,264 6/1977 Woodward ..... 296/164  
D. 230,261 2/1974 Woodward ..... D12/403  
D. 231,443 4/1974 Wayman ..... D12/403  
D. 247,711 4/1978 Pittman ..... D12/403  
D. 266,531 10/1982 Murphy ..... D21/253  
D. 291,074 7/1987 Ravana ..... D12/403  
D. 297,424 8/1988 Norris, III ..... D12/403  
D. 299,817 2/1989 Wolcott et al. .... D12/403  
D. 318,446 7/1991 Magyar et al. .... D12/403  
D. 333,646 3/1993 Levy ..... D12/403  
D. 337,979 8/1993 Napieraj ..... D12/403  
D. 340,689 10/1993 Wolcott et al. .... D12/403  
D. 352,690 11/1994 Schorr ..... D12/404

**1 Claim, 2 Drawing Sheets**

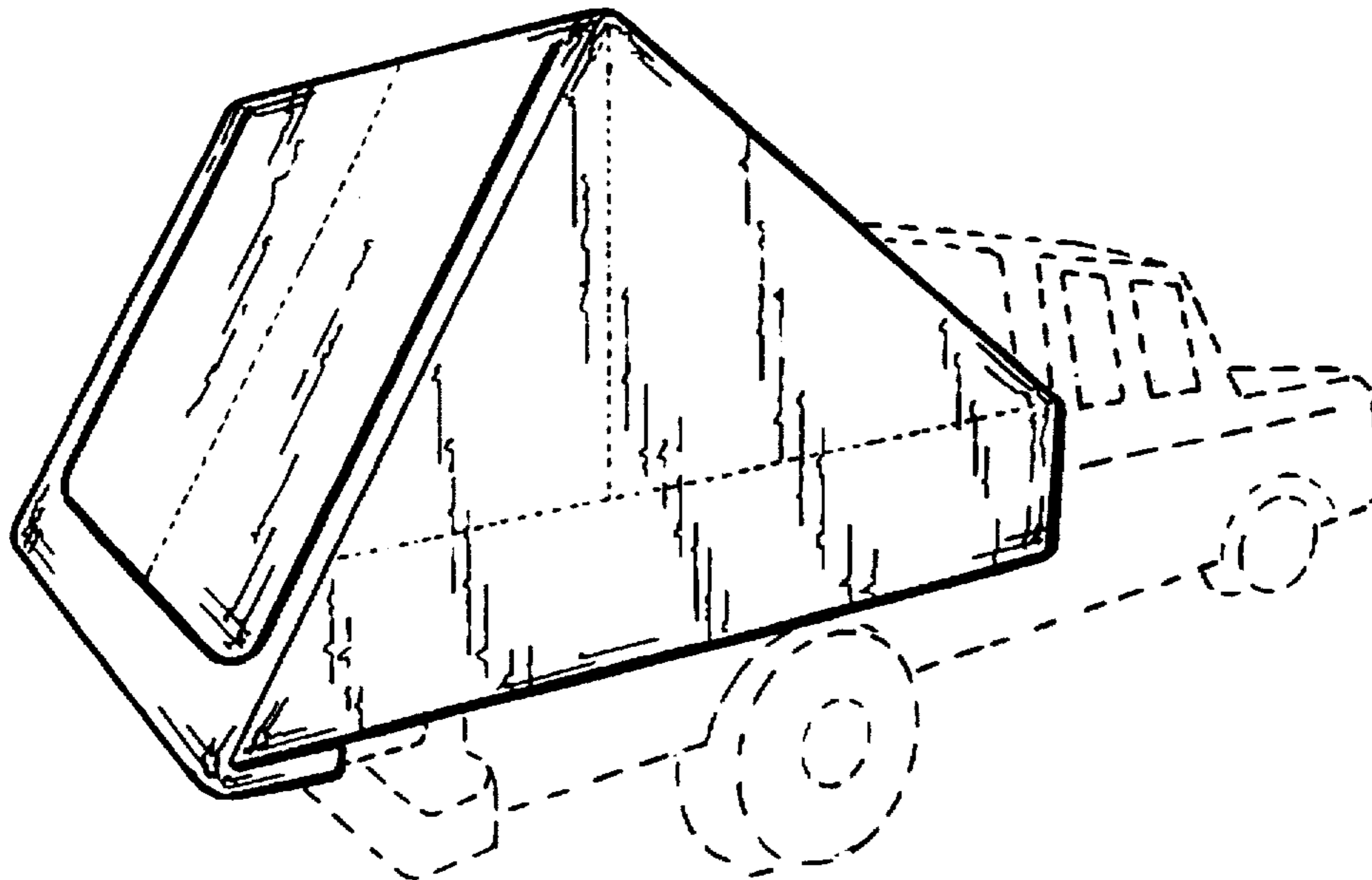

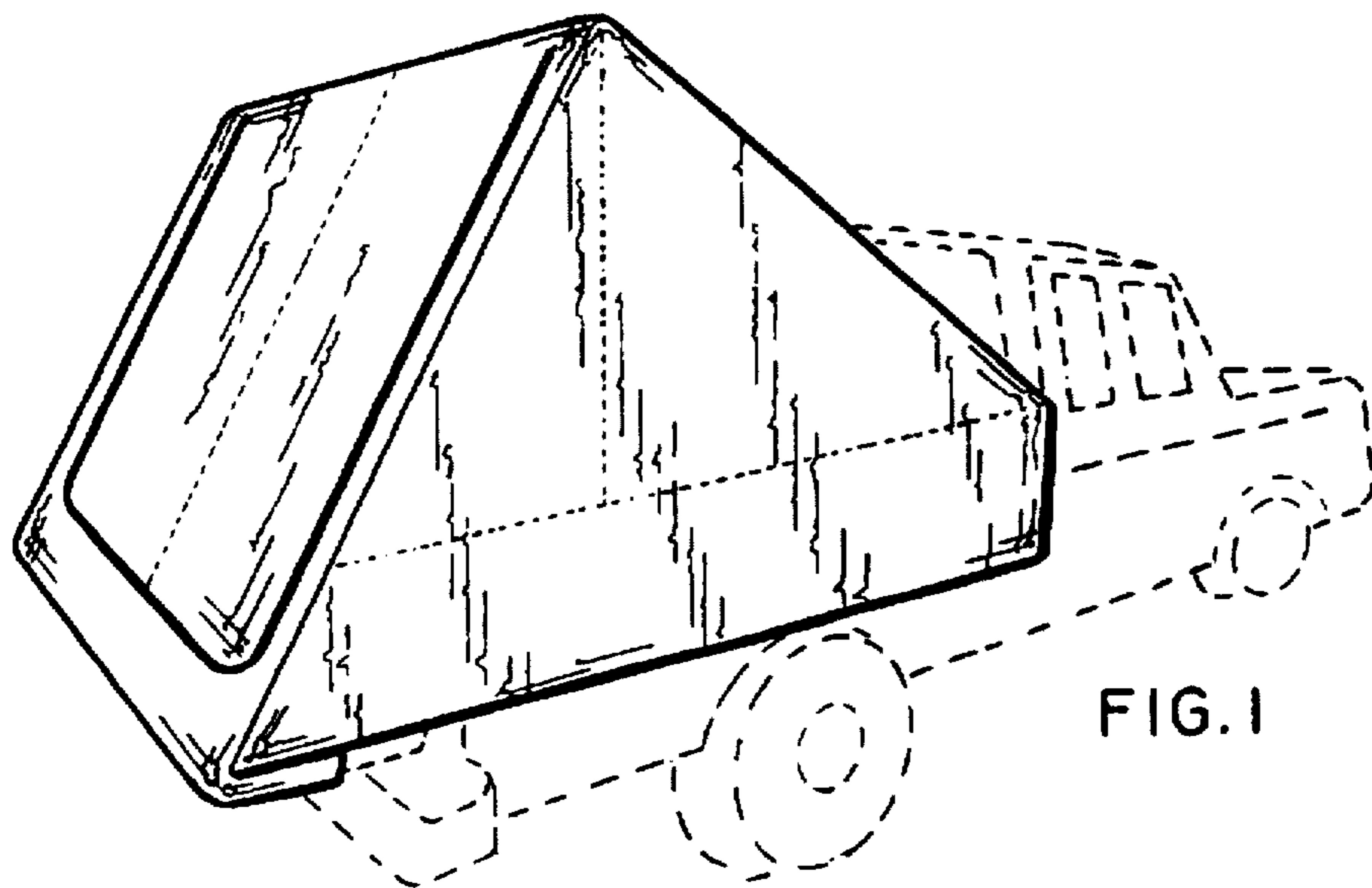

FIG. 1

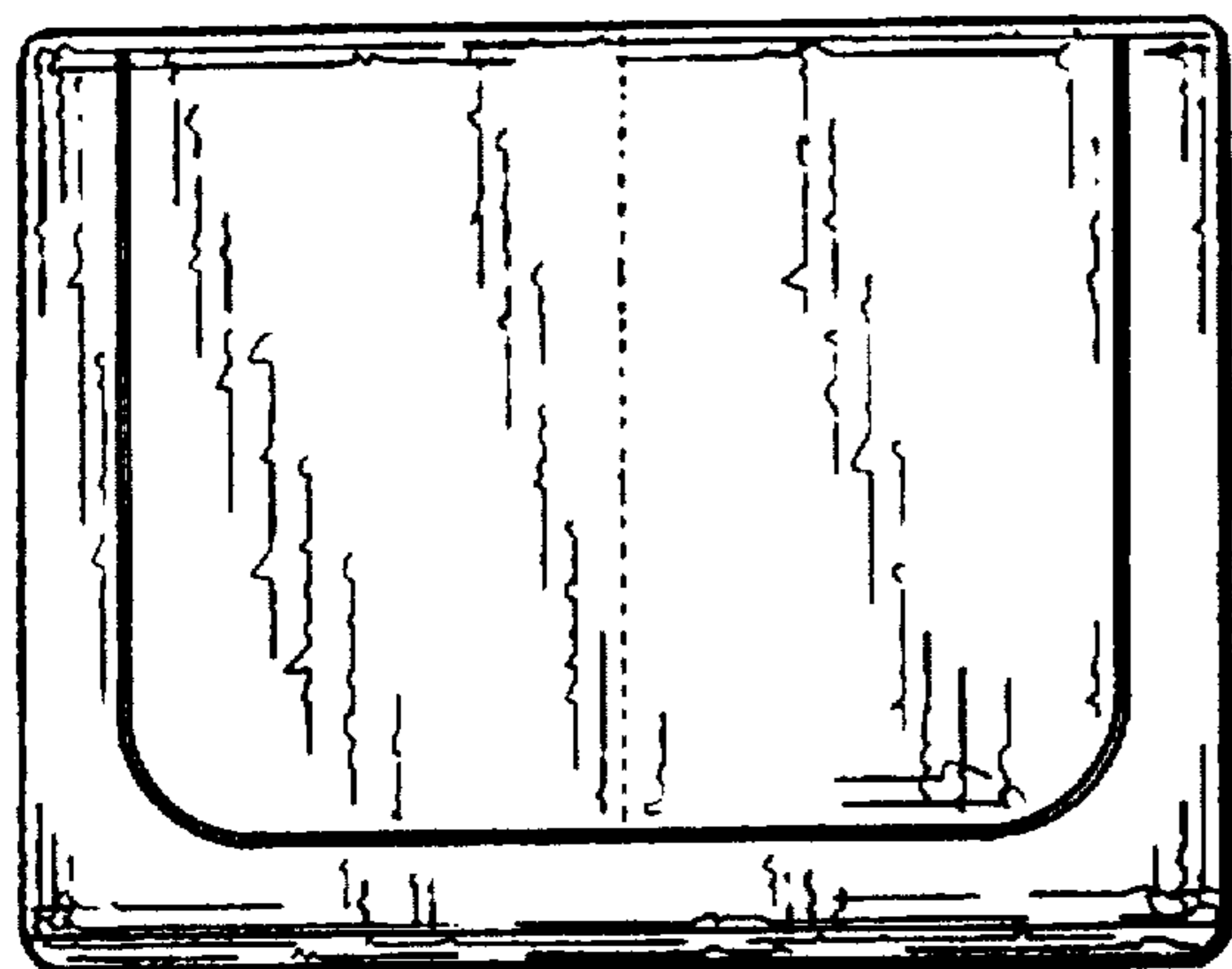

FIG. 2

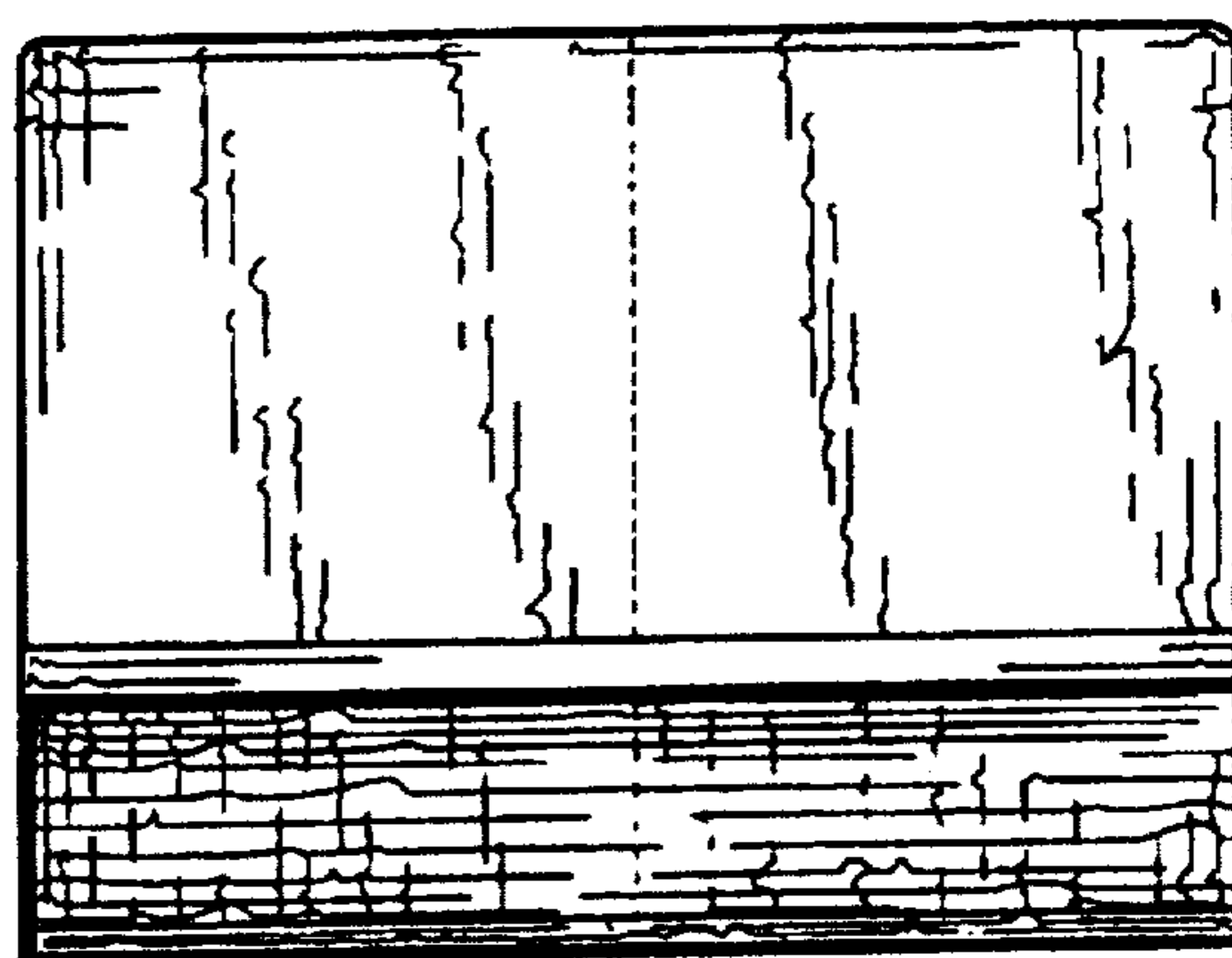

FIG. 3

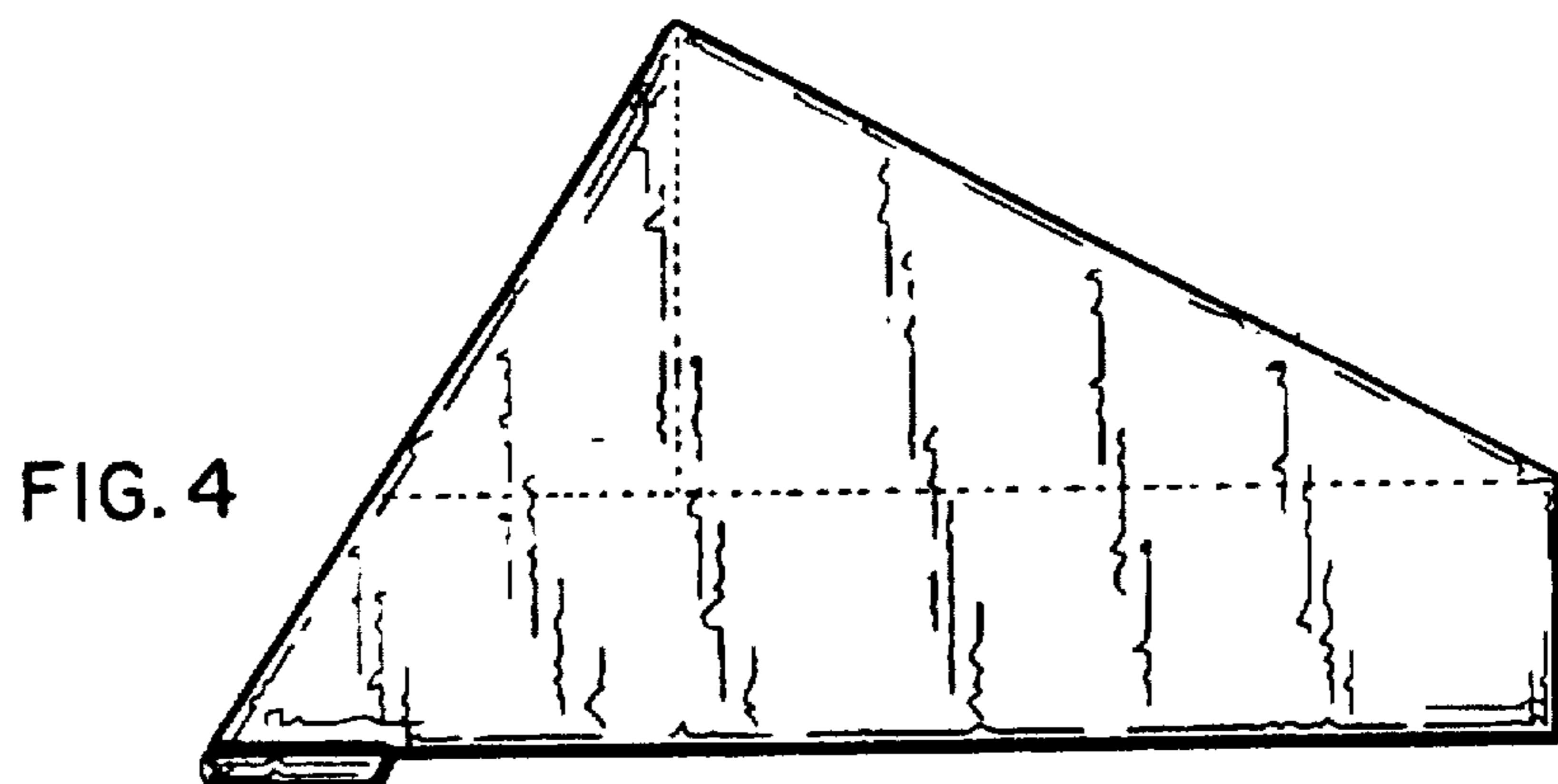

FIG. 4

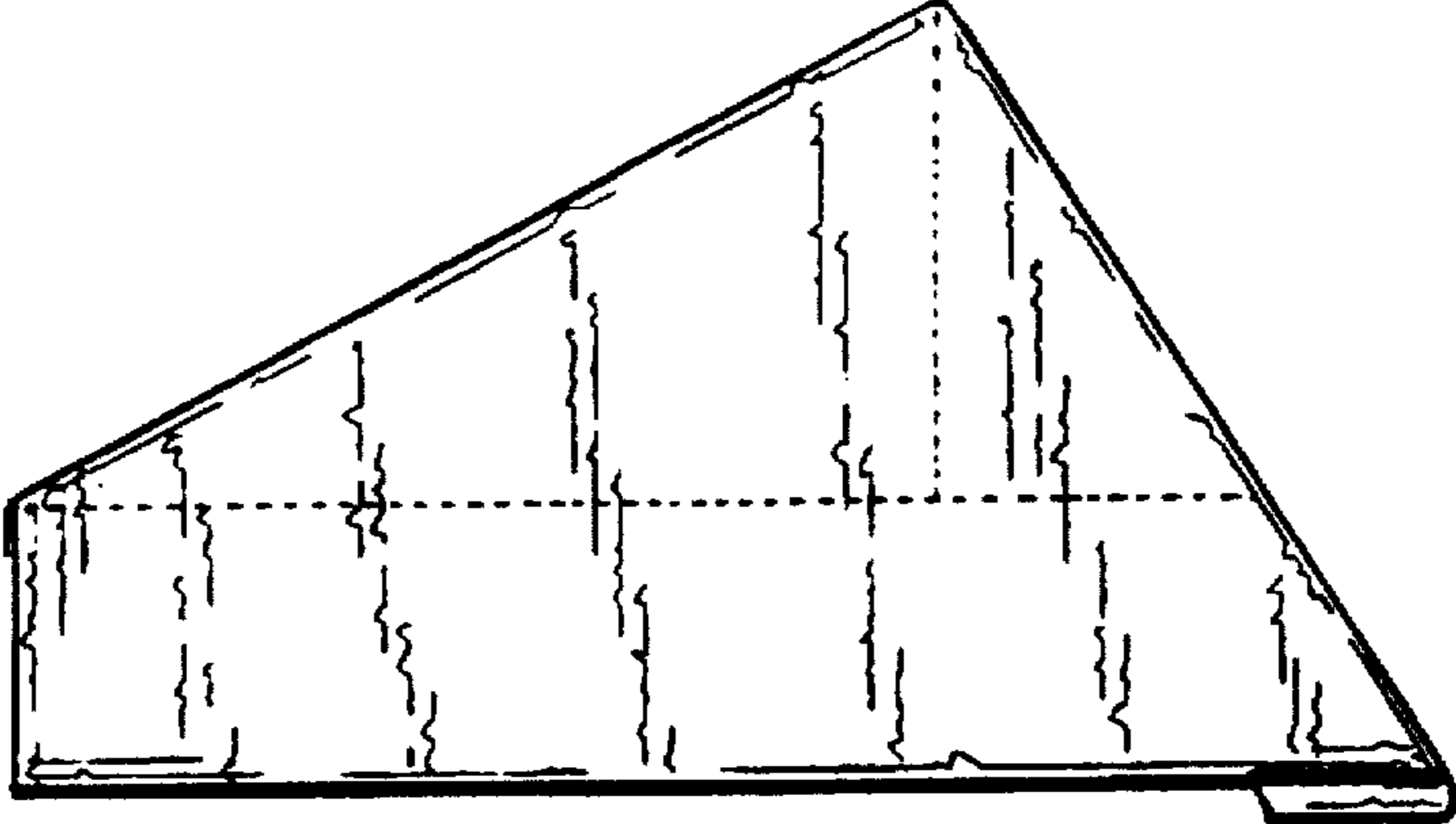

FIG. 5

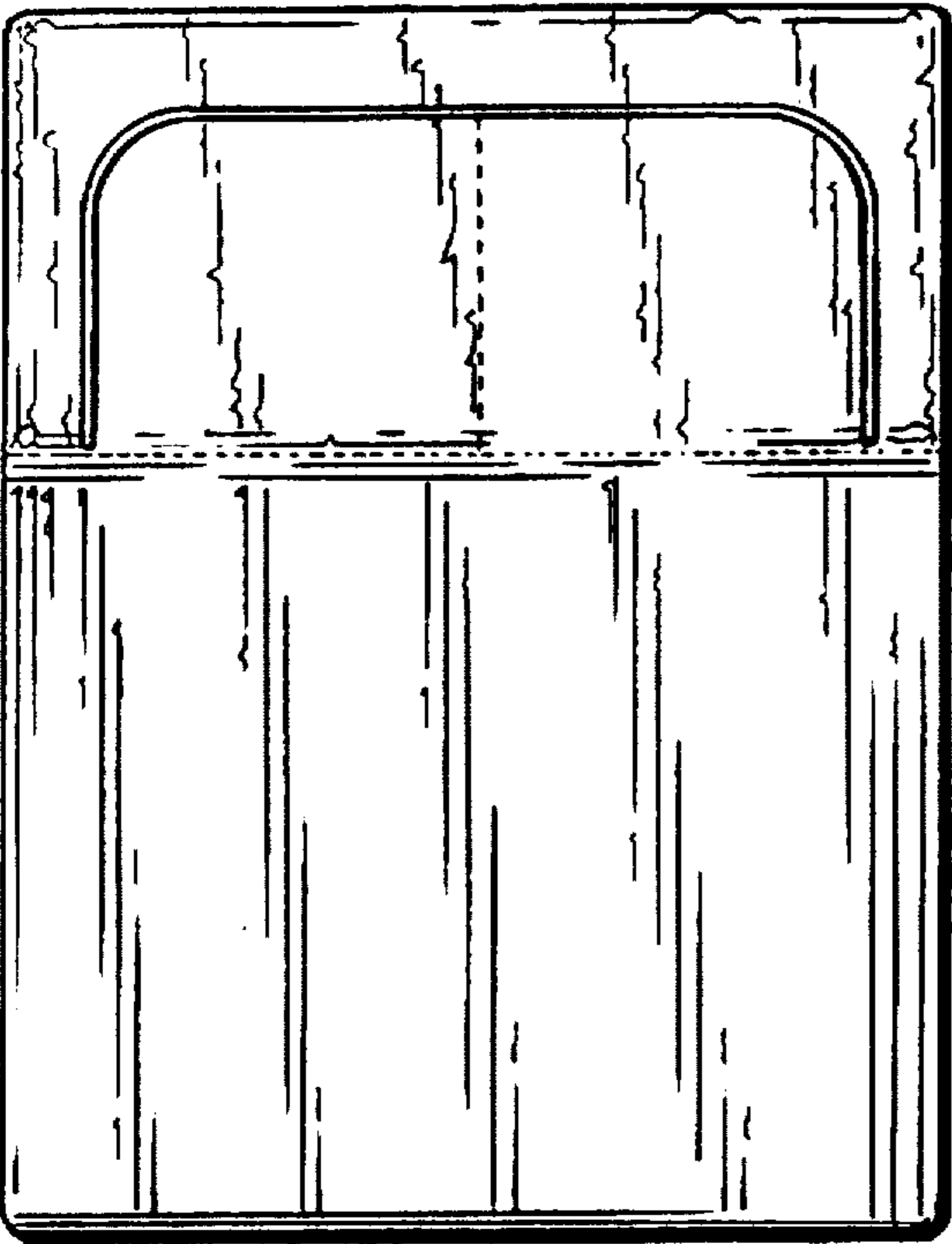

FIG. 6

FIG. 7

