



US00D397662S

United States Patent [19]
LeJuerrne

[11] **Patent Number:** **Des. 397,662**
[45] **Date of Patent:** ****Sep. 1, 1998**

[54] **WHEEL**

[75] **Inventor:** **Richard J. LeJuerrne**, Wellington, Kans.

[73] **Assignee:** **Halibrand Engineering**, Wellington, Kans.

[**] **Term:** **14 Years**

[21] **Appl. No.:** **45,440**

[22] **Filed:** **Oct. 19, 1995**

[51] **LOC (6) Cl.** **12-16**

[52] **U.S. Cl.** **D12/209**

[58] **Field of Search** **D12/204-211;**
301/64.1, 65, 37.1

[56] **References Cited**

U.S. PATENT DOCUMENTS

D. 223,534	5/1972	Reid	D12/209
D. 225,842	1/1973	Clement	D12/209
D. 238,063	12/1975	Clement	D12/209
D. 241,830	10/1976	Patch	D12/211
D. 272,431	1/1984	Hedlund	D12/211
D. 292,569	11/1987	Cafaro et al.	D12/209
D. 361,546	8/1995	Weld	D12/209

Primary Examiner—James Gandy
Assistant Examiner—Stacia Sinuik
Attorney, Agent, or Firm—Townsend and Townsend and Crew

[57] **CLAIM**

The ornamental design for a wheel, as shown and described.

DESCRIPTION

FIG. 1 is a front elevational view or the street side elevational view of the wheel;

FIG. 2 is a side elevational view of one side of the wheel;

FIG. 3 is a rear elevational view or brake drum side elevational view of the wheel;

FIG. 4 is a side elevational view of the wheel, opposite to the side elevational view in FIG. 2;

FIG. 5 is a reduced perspective view of the wheel from a front or street side perspective;

FIG. 6 is an end elevational view of the wheel;

FIG. 7 is another reduced perspective view of the wheel from a rear or brake drum side perspective;

FIG. 8 is an end elevational view of the wheel opposite to the end elevational view in FIG. 6;

FIG. 9 is a vertical sectional view taken in direction of the arrow and along the plane of line 9—9 in FIG. 1;

FIG. 10 is an enlarged vertical sectional view taken in direction of the arrows and along the plane of line 10—10 in FIG. 1;

FIG. 11 is an enlarged vertical sectional view taken in the direction of the arrows and along the plane of line 11—11 in FIG. 3.

1 Claim, 8 Drawing Sheets

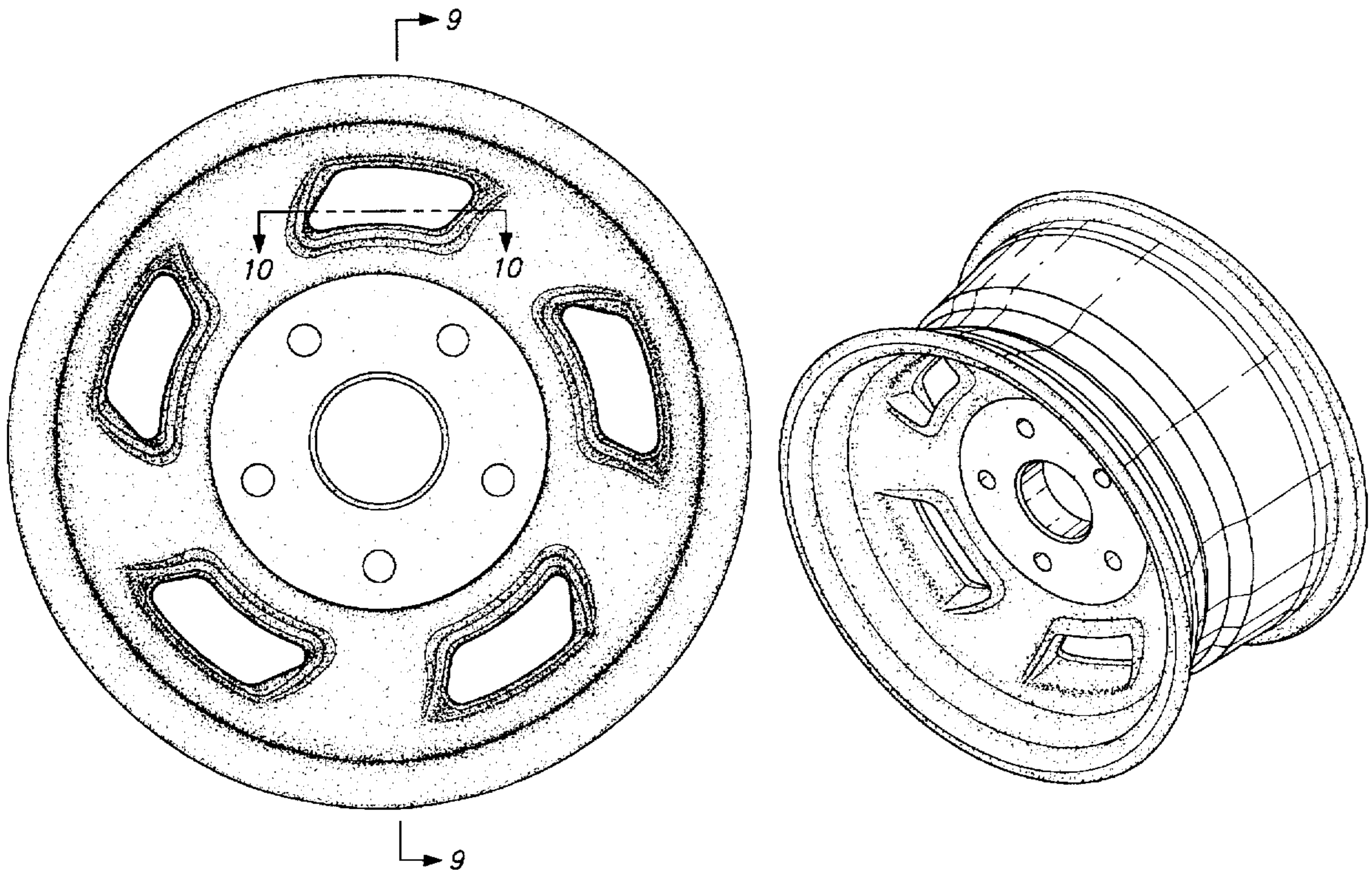

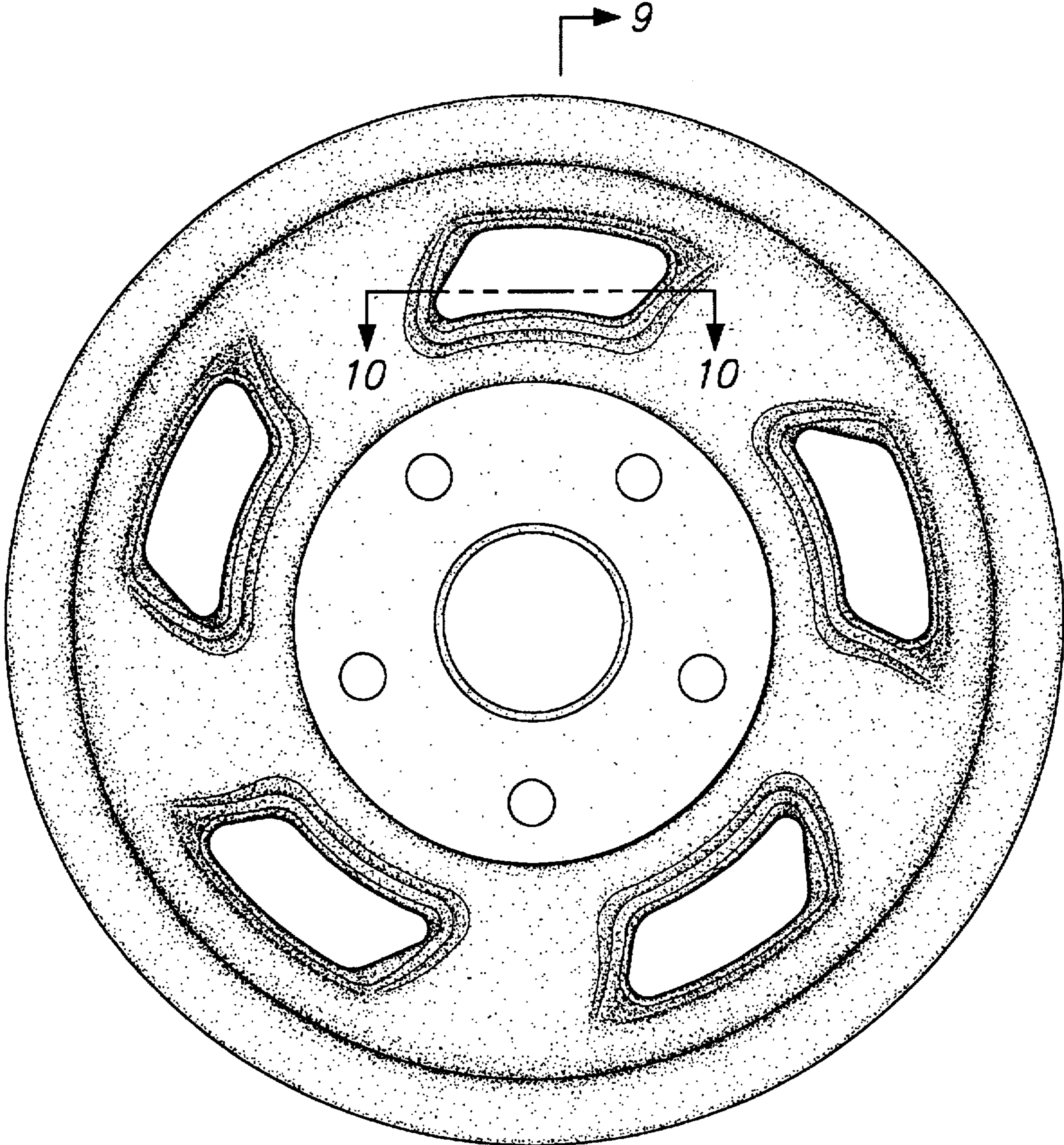

FIG. 1

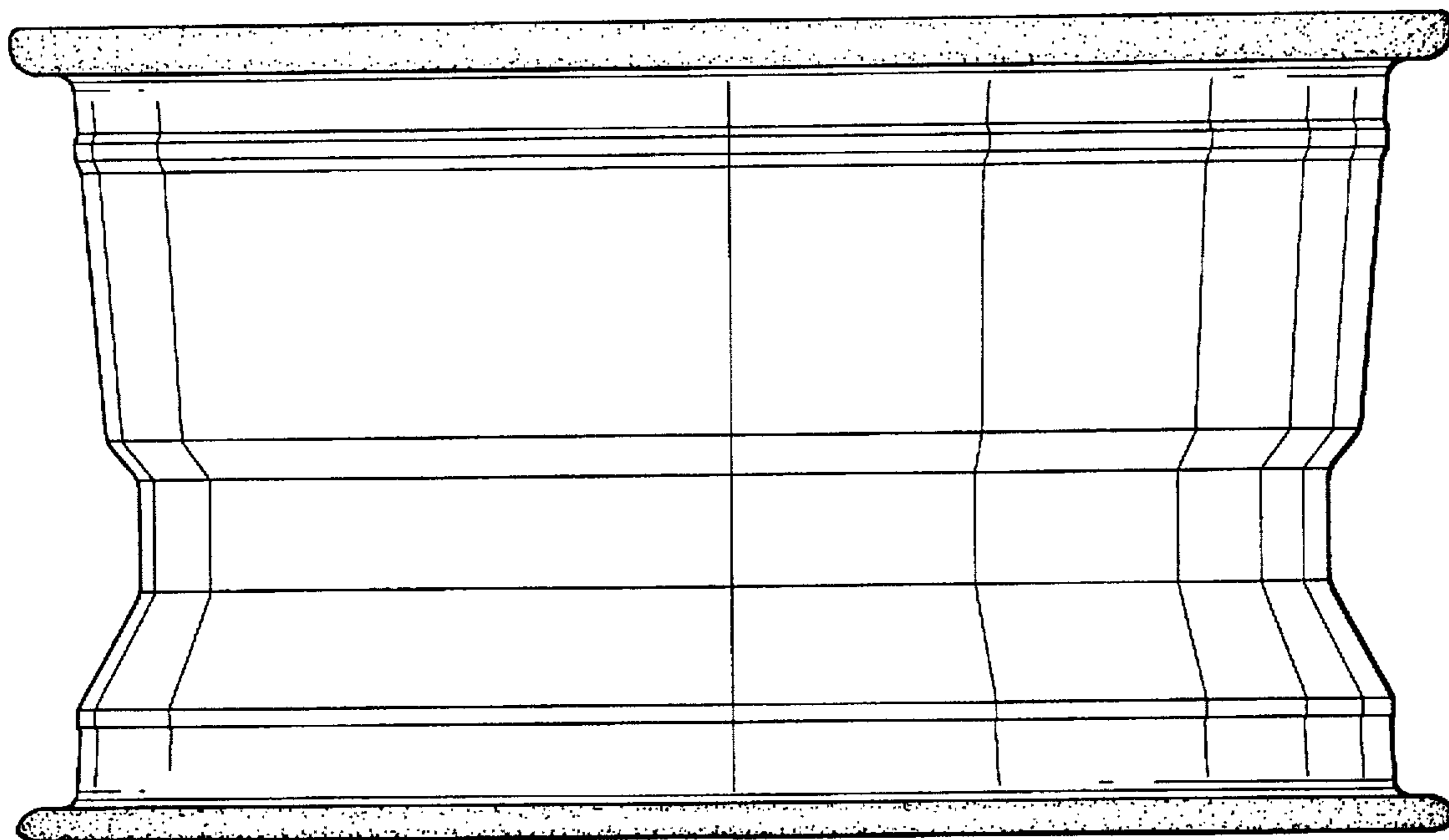

FIG. 2

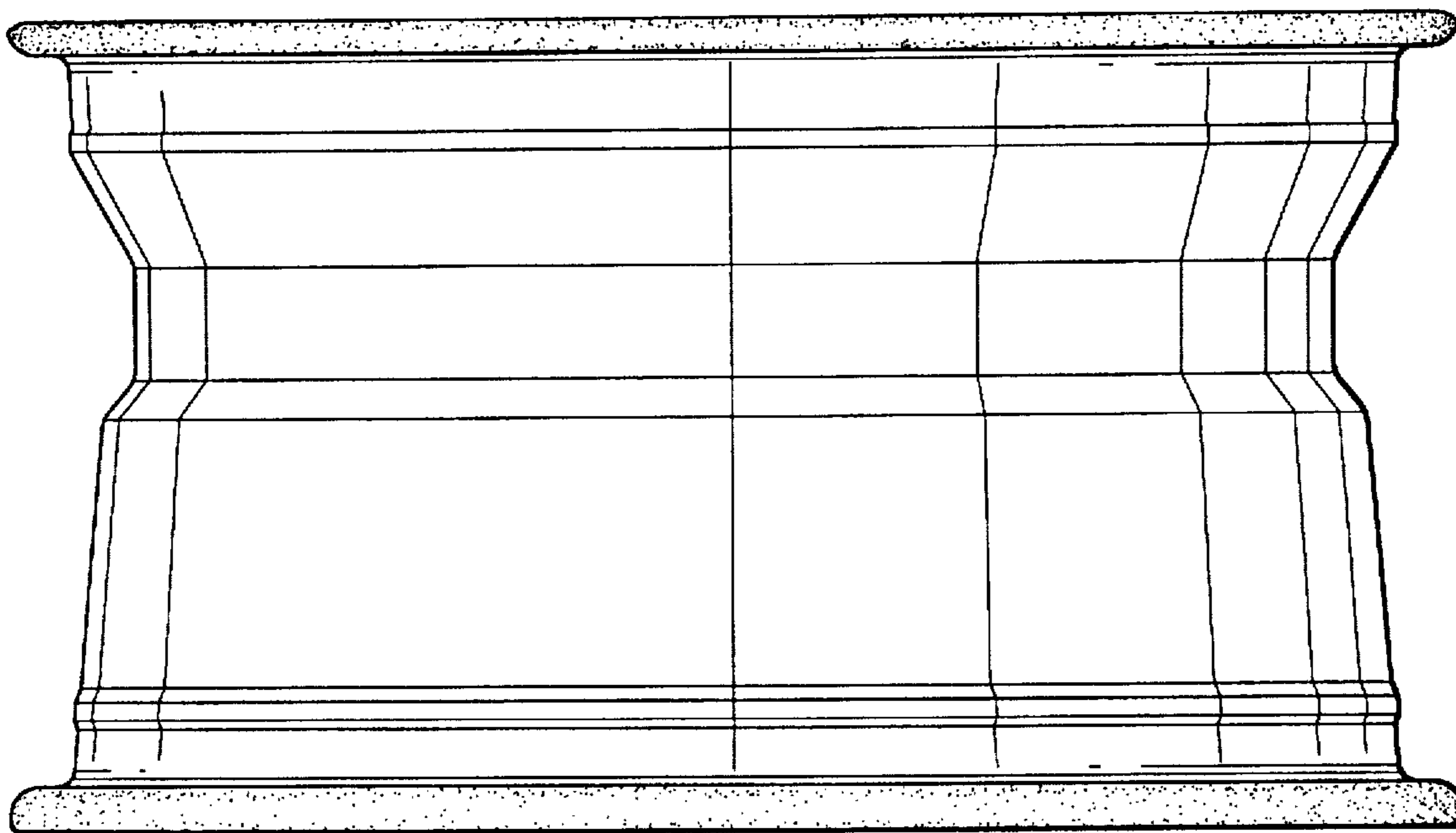

FIG. 4

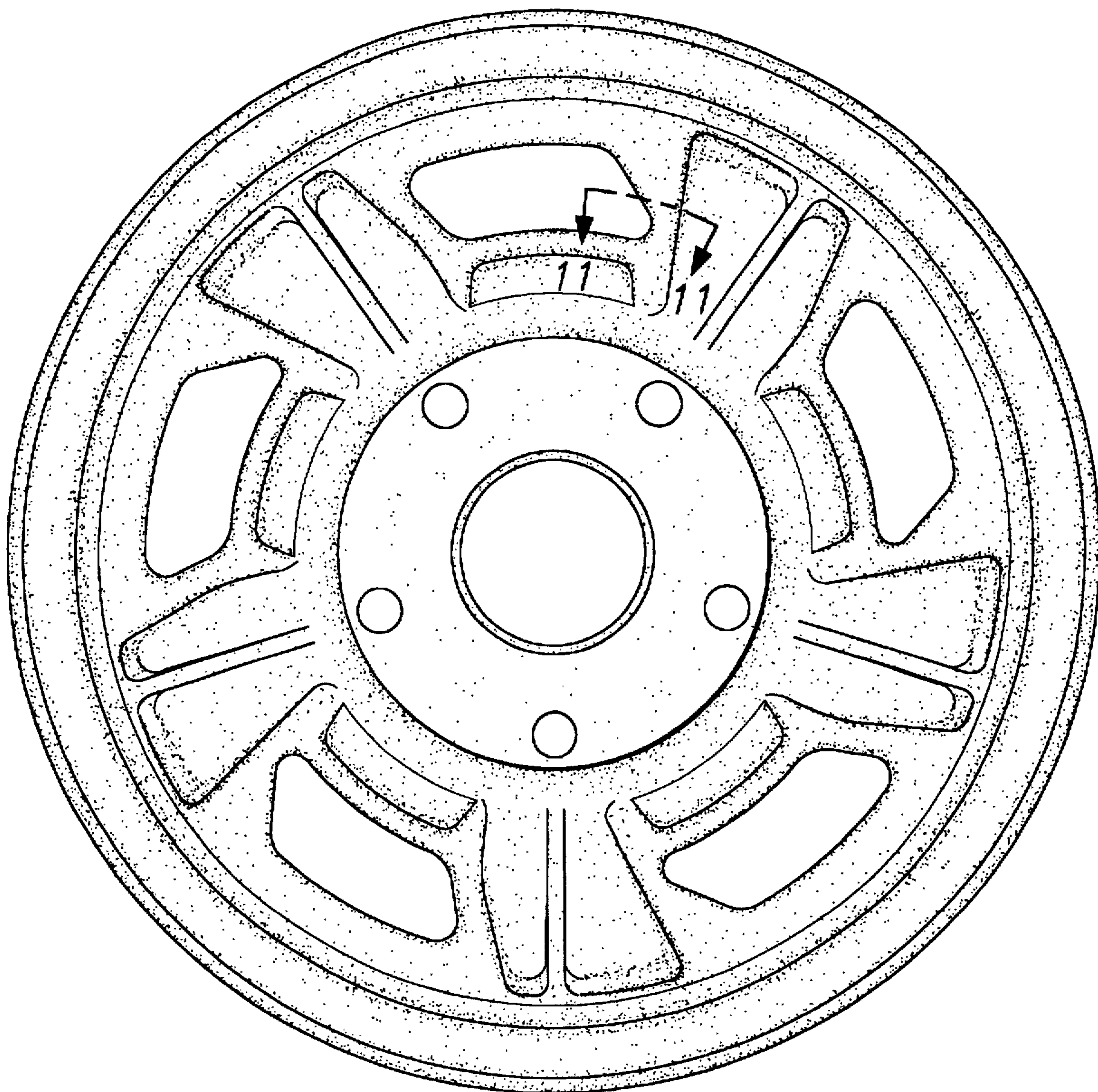

FIG. 3

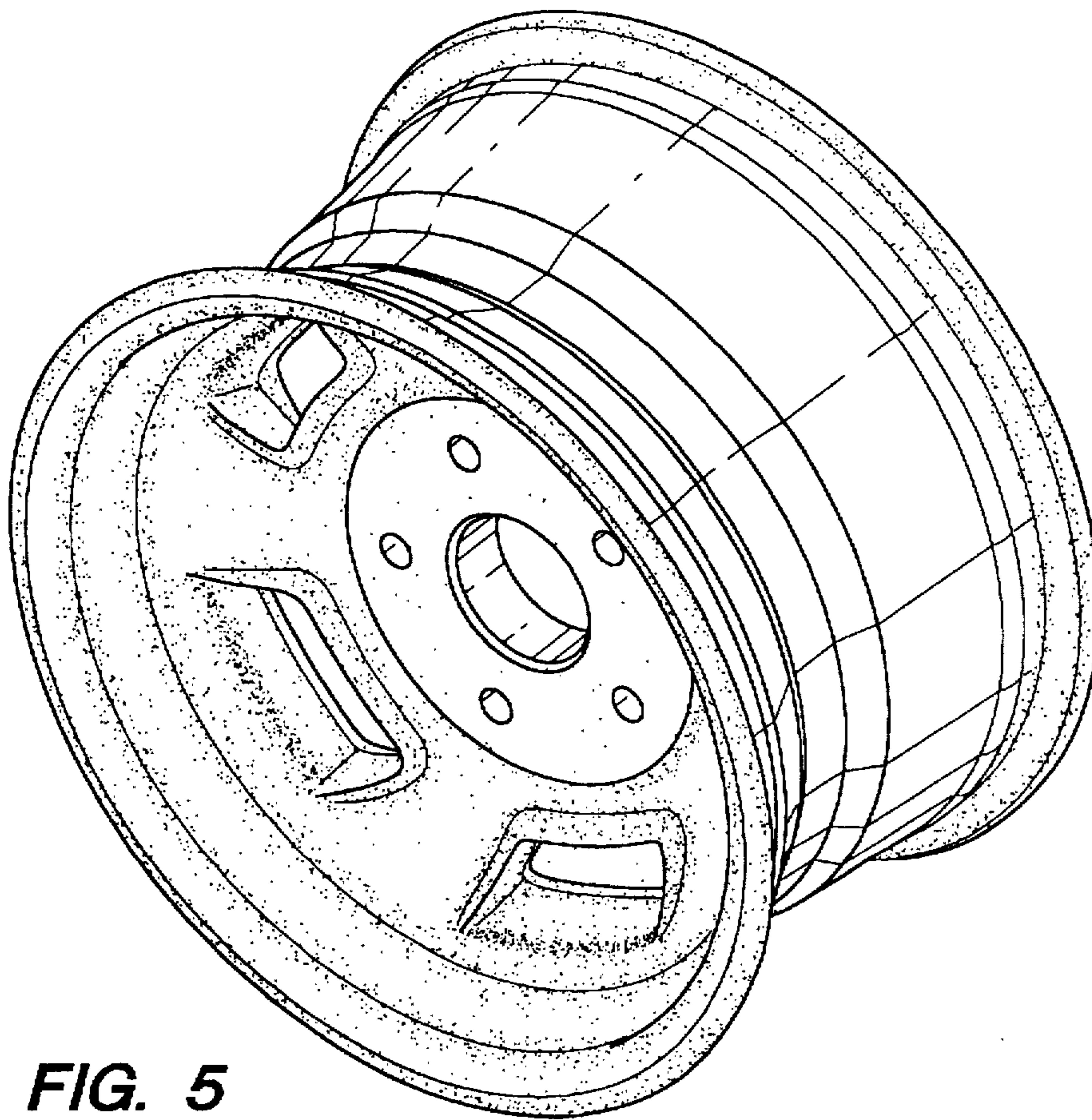

FIG. 5

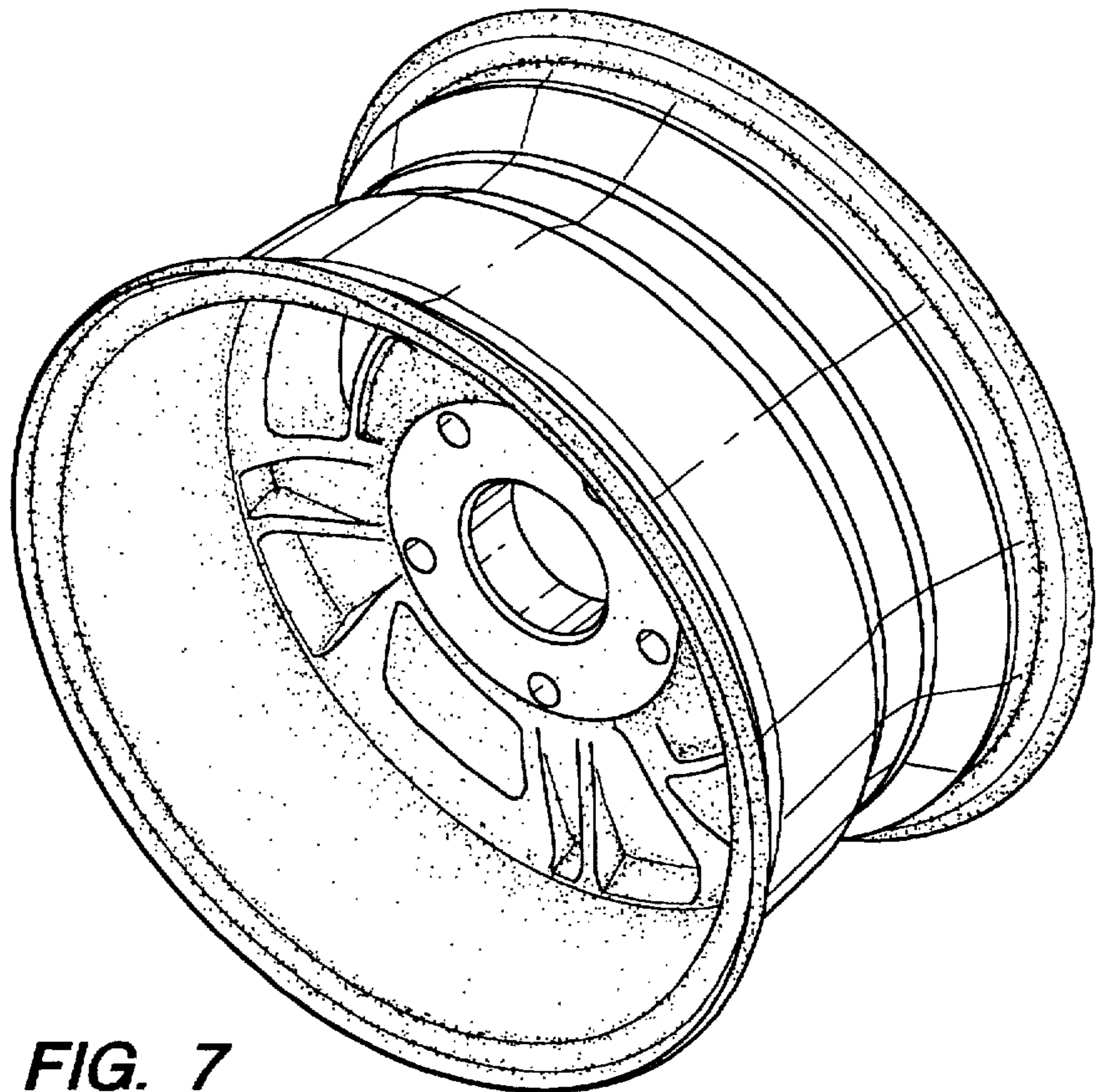

FIG. 7

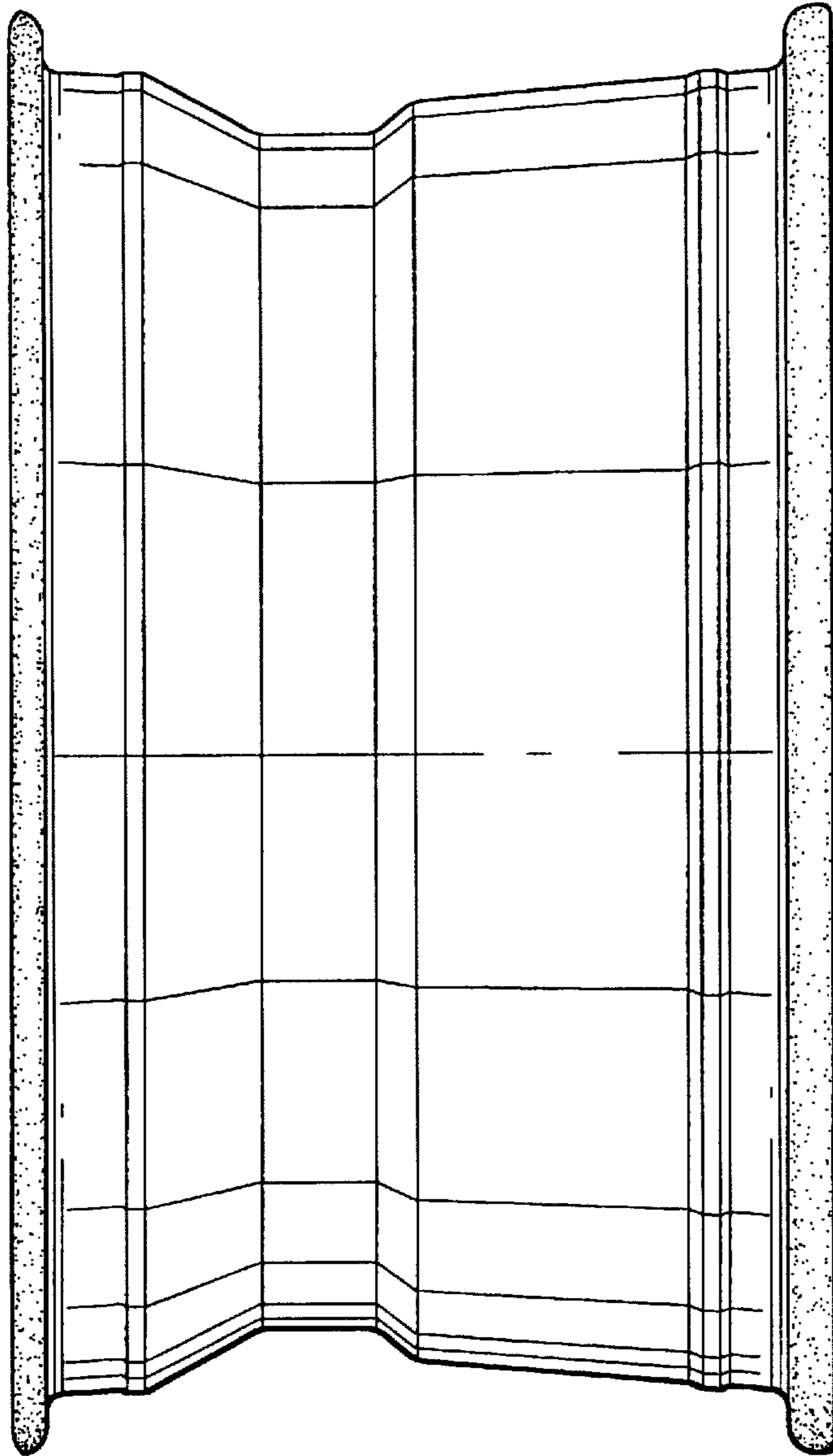

FIG. 6

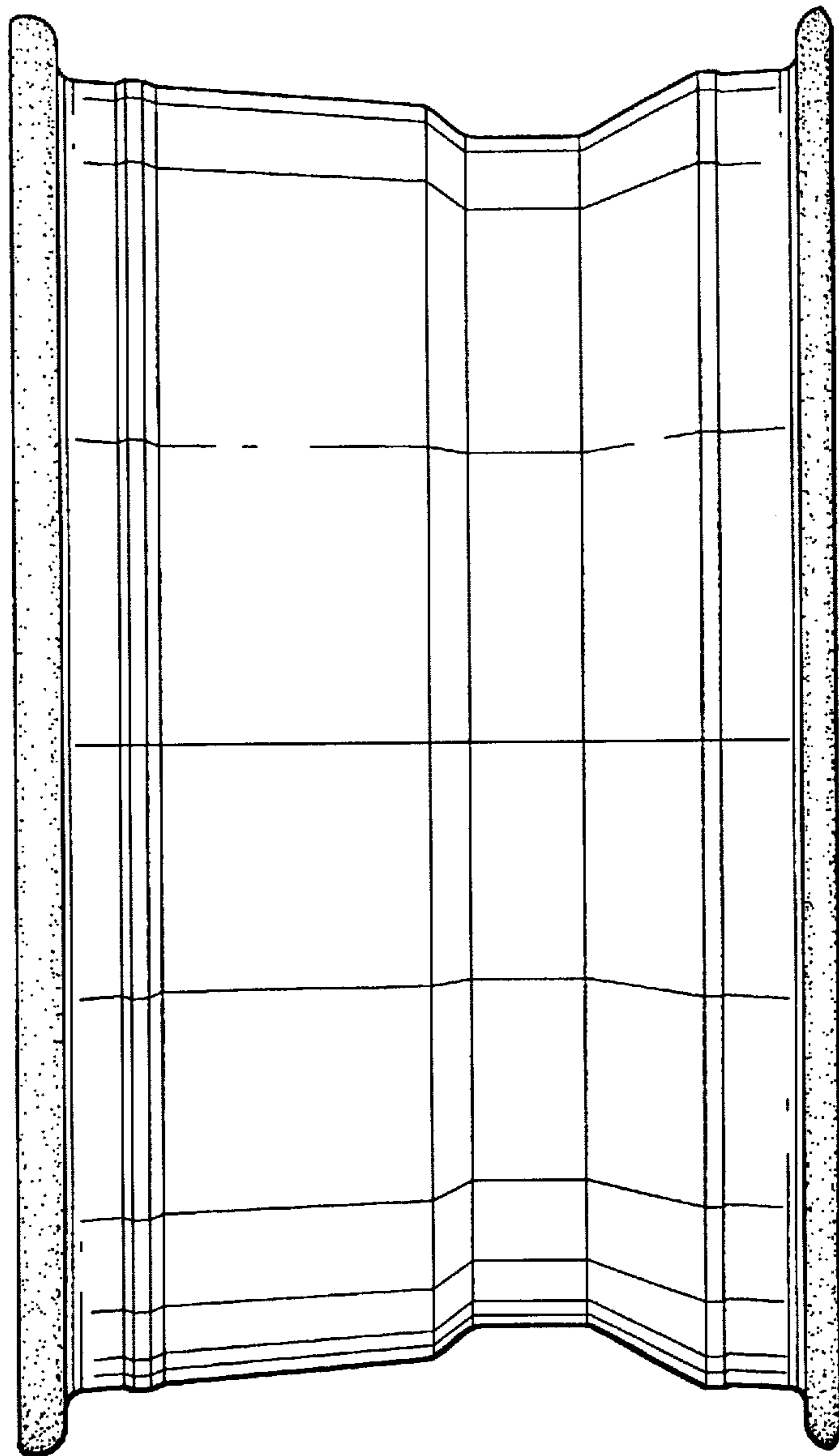

FIG. 8

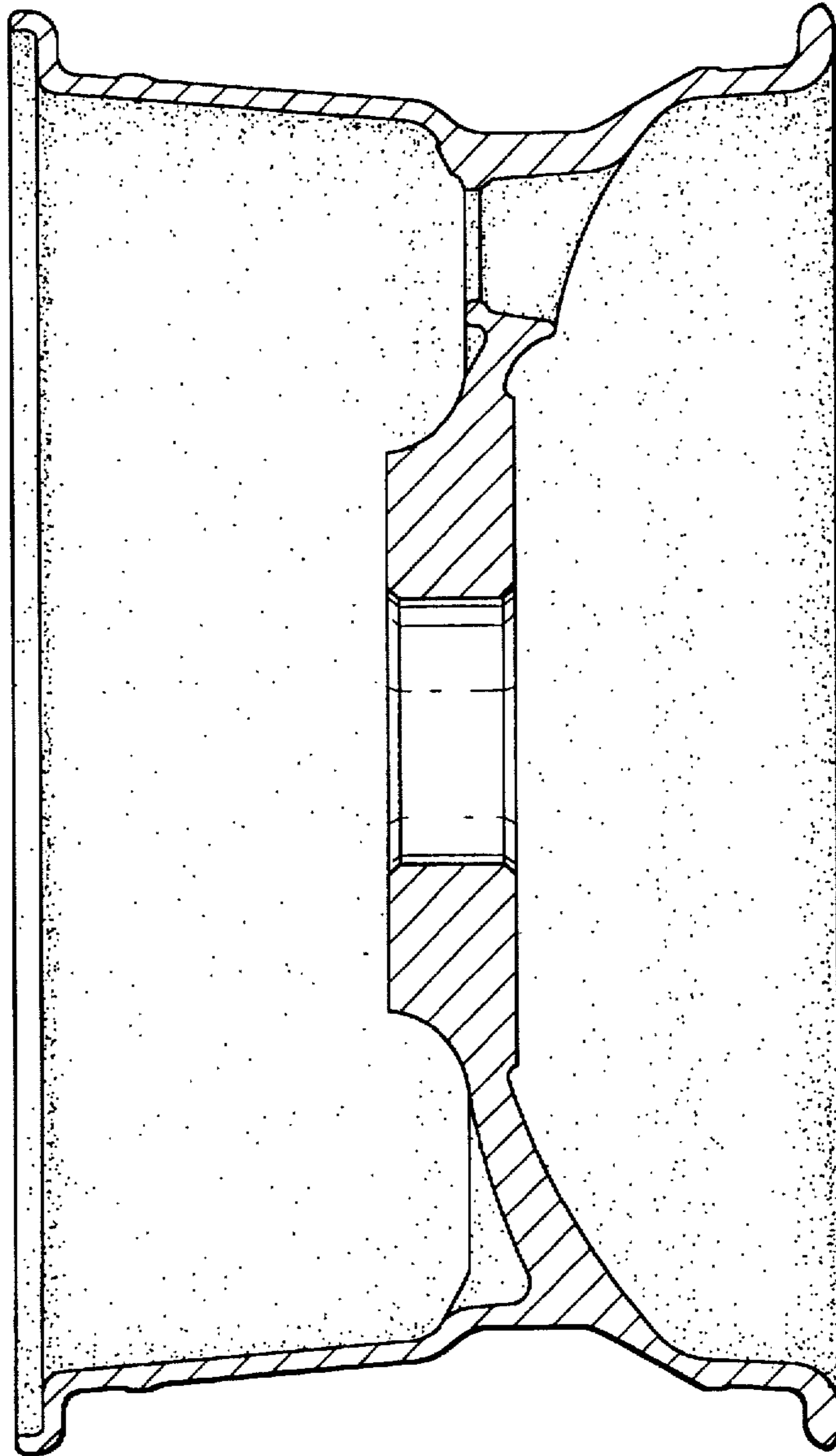

FIG. 9

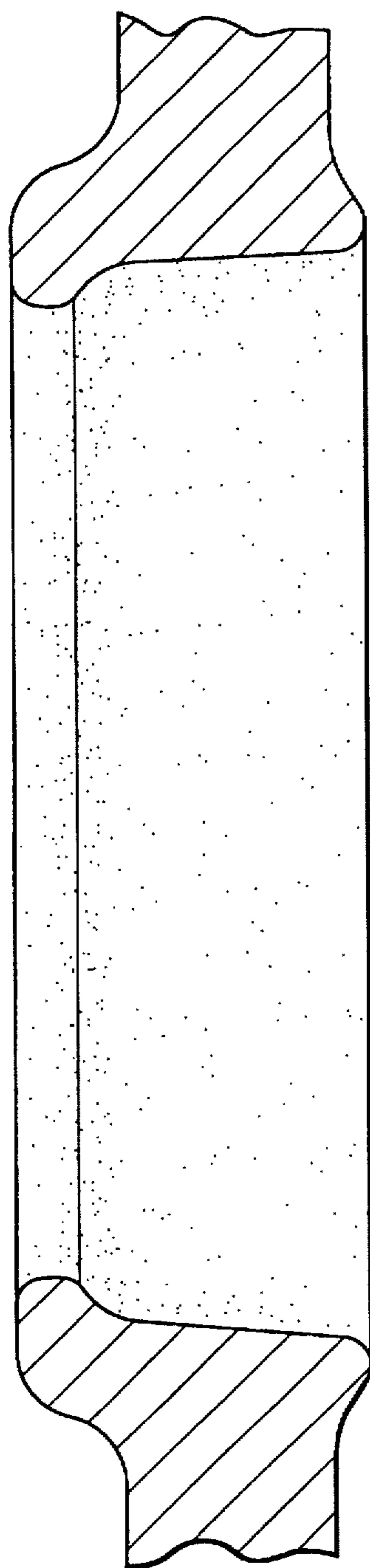

FIG. 10

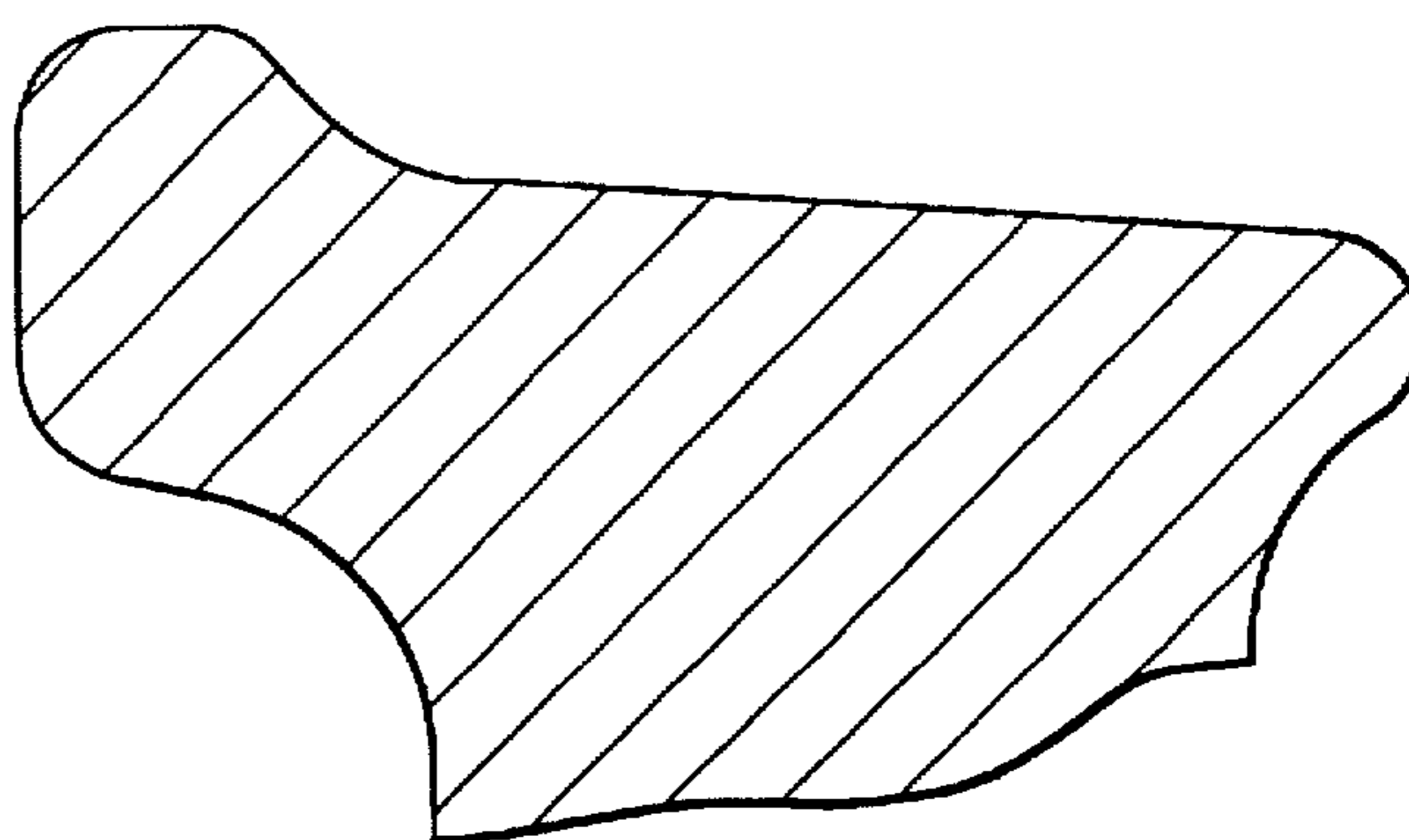

FIG. 11