



US00D397320S

United States Patent [19]
Hoagland, IV

[11] **Patent Number: Des. 397,320**
[45] **Date of Patent: **Aug. 25, 1998**

[54] **GAS CAP**

[76] **Inventor: Calvin C. Hoagland, IV, 6 Widewater Rd., Hilton Head Island, S.C. 29926-2021**

[**] **Term: 14 Years**

[21] **Appl. No.: 79,712**

[22] **Filed: Nov. 21, 1997**

Related U.S. Application Data

[62] **Division of Ser. No. 58,301, Jul. 11, 1996, Pat. No. Des. 390,507.**

[51] **LOC (6) Cl. 12-16**

[52] **U.S. Cl. D12/197**

[58] **Field of Search D12/197; D9/453; 220/86.1, 86.2, 209, 254, 334**

[56] **References Cited**

U.S. PATENT DOCUMENTS

- D. 51,851 11/1918 Bloom D9/439
- D. 58,630 8/1921 Ruckman D12/197
- D. 104,786 7/1937 Lumiere D12/83
- D. 149,122 10/1948 Goodwin D12/194
- D. 178,648 9/1956 Collura D12/189
- D. 190,025 4/1961 Stortz D12/189
- D. 192,852 5/1962 Walker D12/189
- D. 246,038 10/1977 Moller D12/194
- D. 250,467 12/1978 O'Banion D12/197
- D. 266,167 9/1982 Lindbrandt D15/5

- D. 266,833 11/1982 Wharton D12/83
- D. 273,373 4/1984 Levine et al. D12/83
- D. 332,838 1/1993 Lu D6/28
- D. 340,513 10/1993 Stahel, II et al. D12/114
- D. 348,645 7/1994 Hitchcock et al. D12/197
- D. 353,357 12/1994 Weinberg et al. D12/197
- D. 354,460 1/1995 Davidson et al. D12/126
- D. 363,259 10/1995 Davidson et al. D12/126
- D. 390,507 2/1998 Hoagland D12/126
- 618,634 1/1899 Young et al. 296/21
- 3,021,757 9/1962 Ellis, Jr. 359/508
- 4,946,060 8/1990 Sherwood et al. 226/86.2
- 5,071,018 12/1991 Moore 220/86.2

OTHER PUBLICATIONS

Drug Specialties Catalog, 1995, p. 160. the two wheel thunder aluminum performance are cleaners.

Primary Examiner—Melody N. Brown

Attorney, Agent, or Firm—Jacobson, Price, Holman & Stern, PLLC

[57] **CLAIM**

The ornamental design for a gas cap, as shown and described.

DESCRIPTION

FIG. 1 is a perspective view showing my new design for a gas cap;
FIG. 2 is a side elevational view thereof;
FIG. 3 is a top plan view thereof; and,
FIG. 4 is a bottom view thereof.

1 Claim, 1 Drawing Sheet

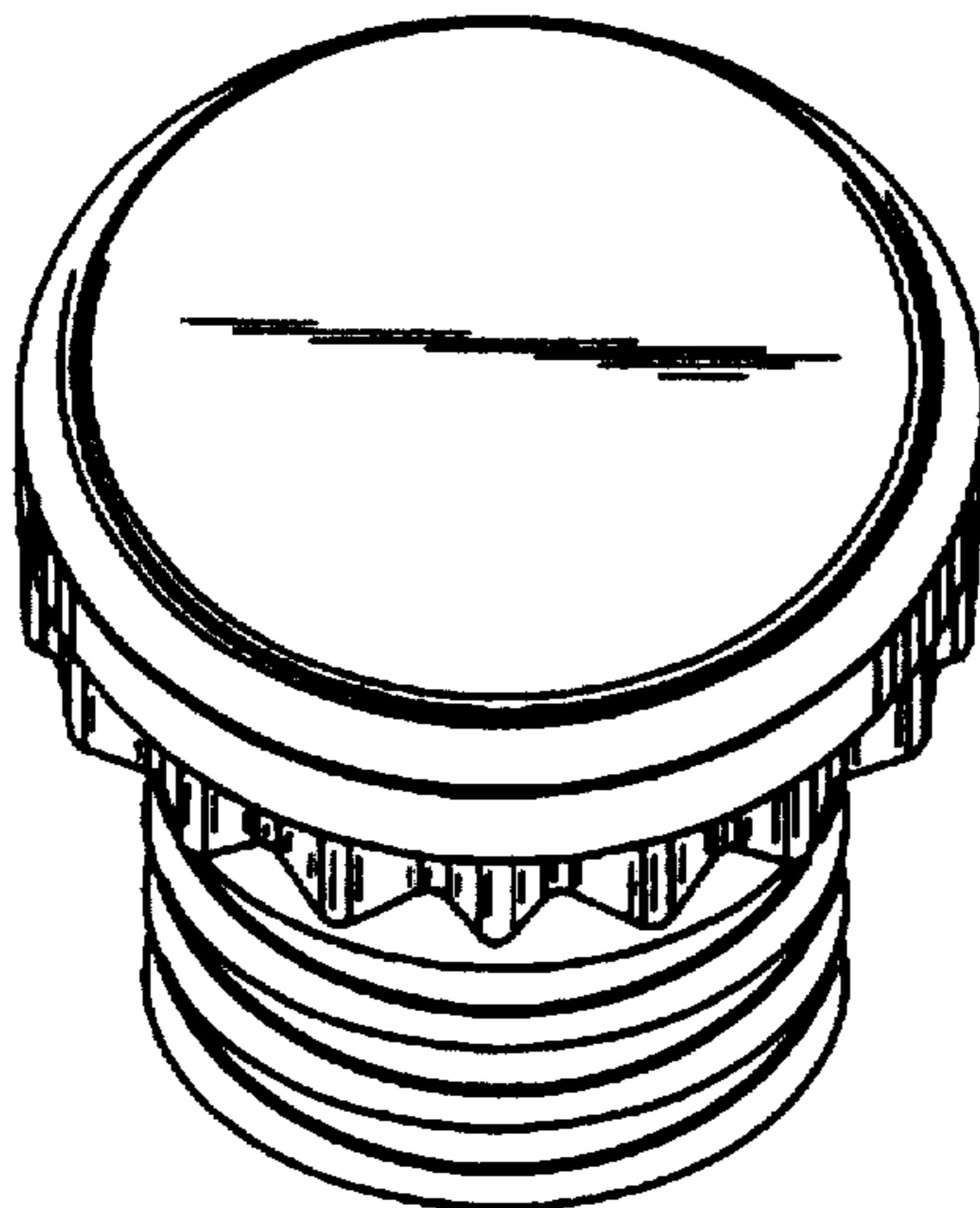

FIG. 1

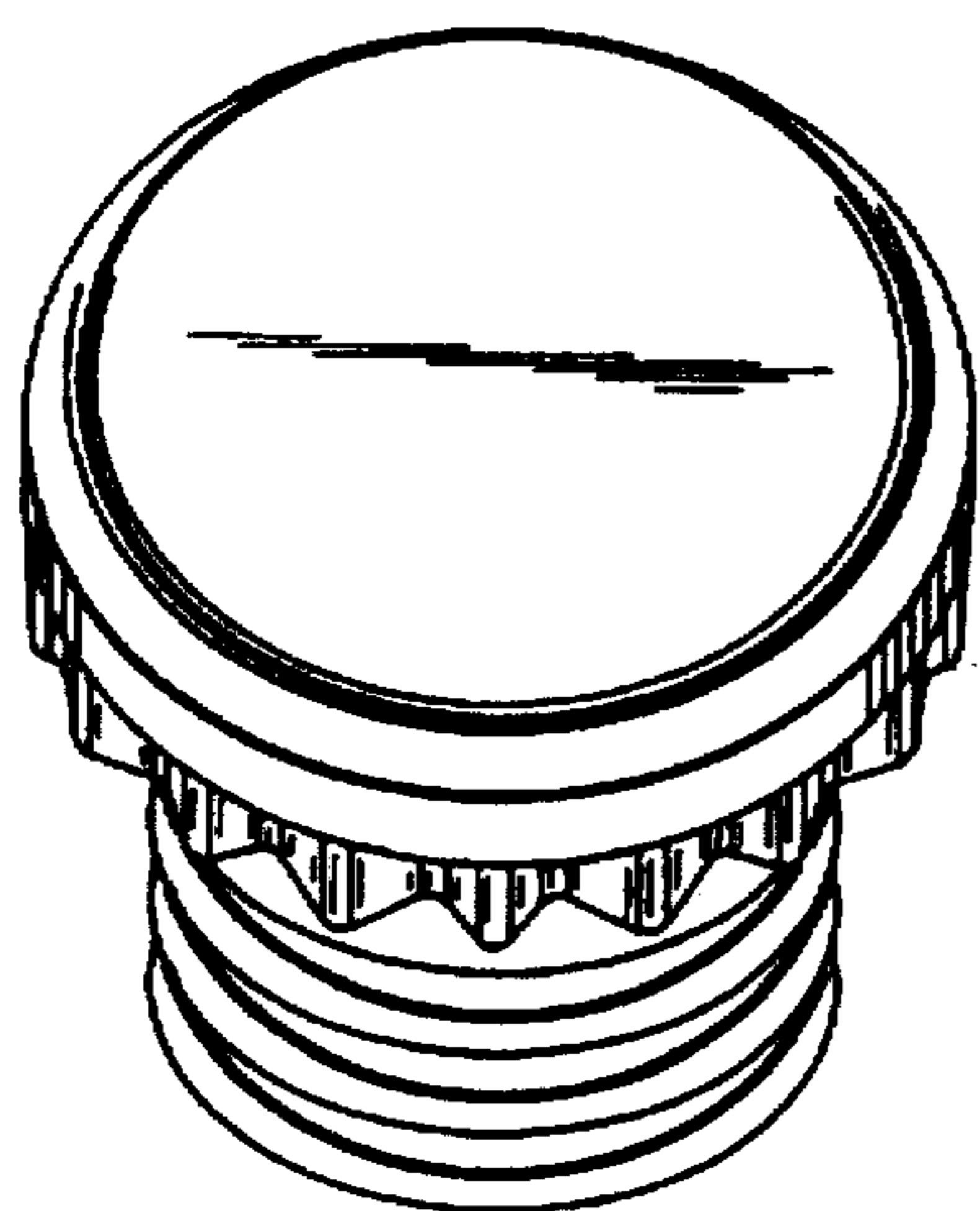

FIG. 2

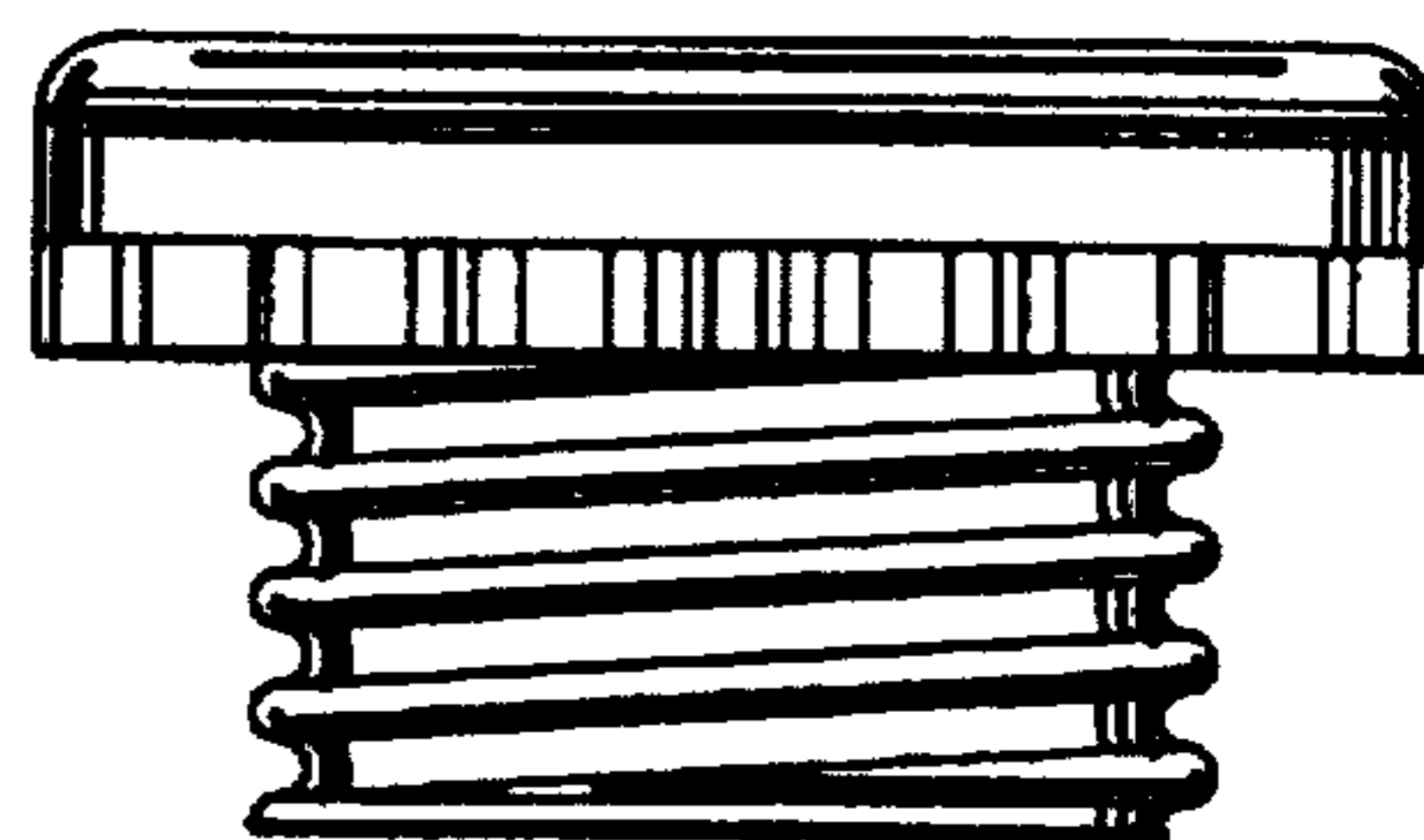

FIG. 3

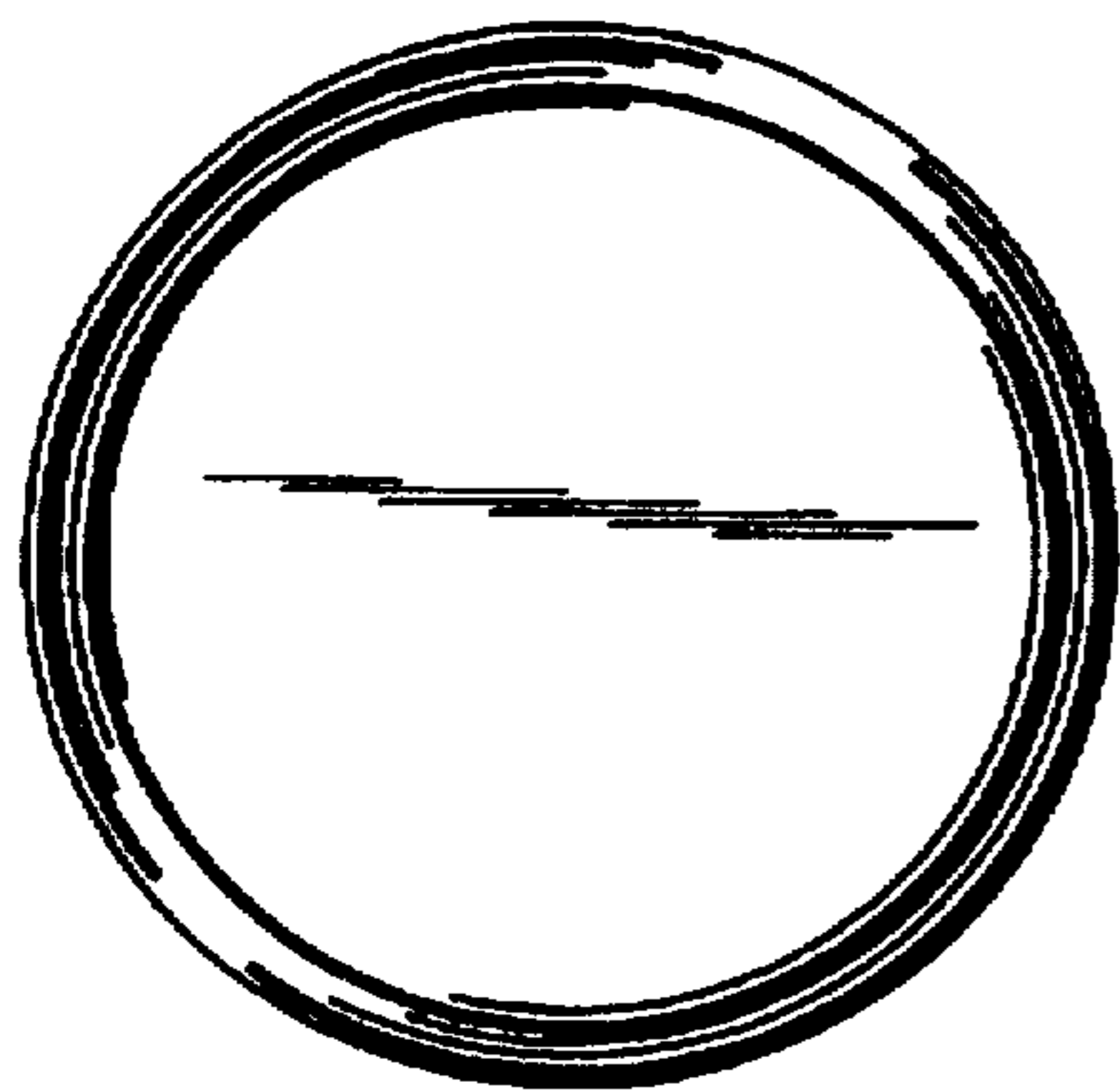

FIG. 4

