



US00D397189S

United States Patent [19]

[11] Patent Number: **Des. 397,189**

Pierret et al.

[45] Date of Patent: ****Aug. 18, 1998**

[54] **LUGGAGE CARRIER FOR BICYCLE**

[76] Inventors: **Johan Maria Alfons Pierret; Karel Lydia Willem Pierret**, both of Breughelstraat 48, B-2018 Antwerpen, Belgium

[**] Term: **14 Years**

[21] Appl. No.: **71,152**

[22] Filed: **May 22, 1997**

[30] **Foreign Application Priority Data**

Nov. 27, 1996 [BE] Belgium 06005-01

[51] LOC (6) Cl. **12-16**

[52] U.S. Cl. **D12/408**

[58] Field of Search D12/407; 224/412-416, 224/422, 424, 425, 427

[56] **References Cited**

U.S. PATENT DOCUMENTS

D. 185,323 5/1959 Schrevkgost D12/407

D. 203,960	3/1966	Stone	D12/407
D. 222,984	2/1972	Heltzer et al.	D12/407
D. 255,561	6/1980	Pold et al.	D12/407
D. 311,510	10/1990	Royce	D12/407
D. 332,540	1/1993	Peterson	D12/407
4,948,020	8/1990	Smith	224/416

Primary Examiner—Melody M. Brown
Attorney, Agent, or Firm—Bacon & Thomas

[57] **CLAIM**

The ornamental design for a luggage carrier for bicycle, as shown and described.

DESCRIPTION

FIG. 1 is an upper right side perspective of the luggage carrier for bicycle showing our new design; FIG. 2 is a right side elevational view thereof; FIG. 3 is a left side elevational view thereof; FIG. 4 is a front view thereof; FIG. 5 is a bottom plan view thereof; and, FIG. 6 is a top plan view thereof.

1 Claim, 5 Drawing Sheets

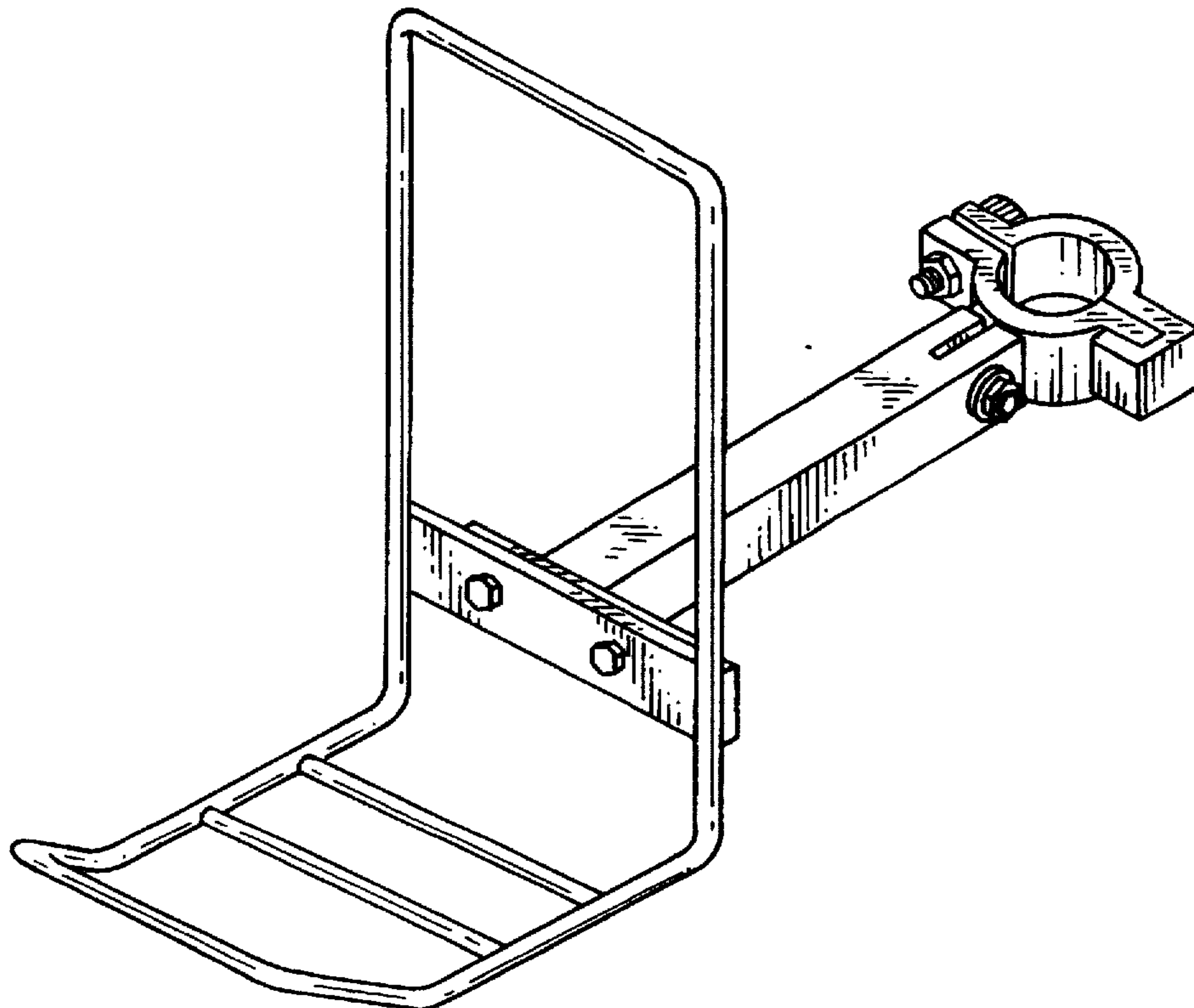

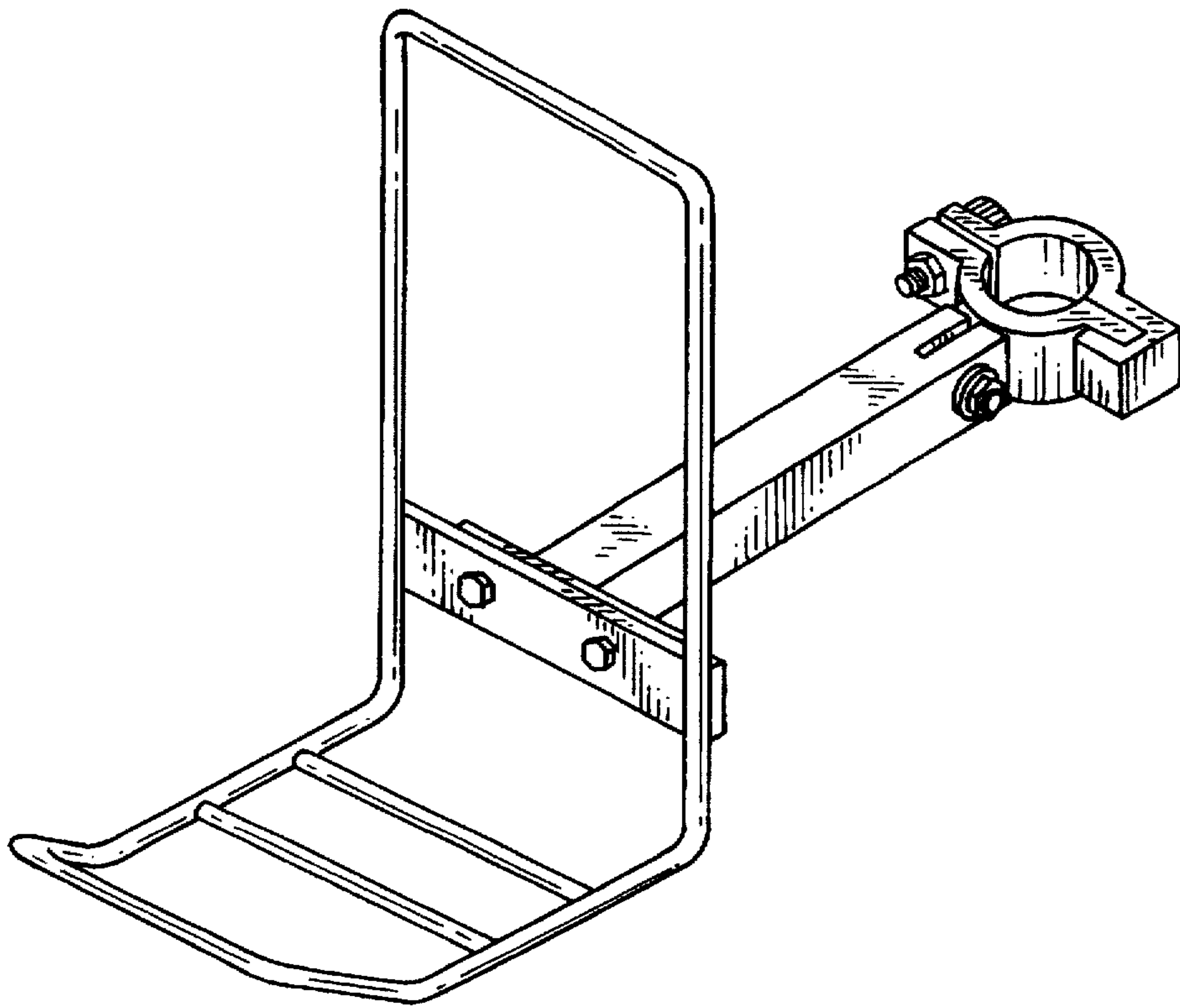
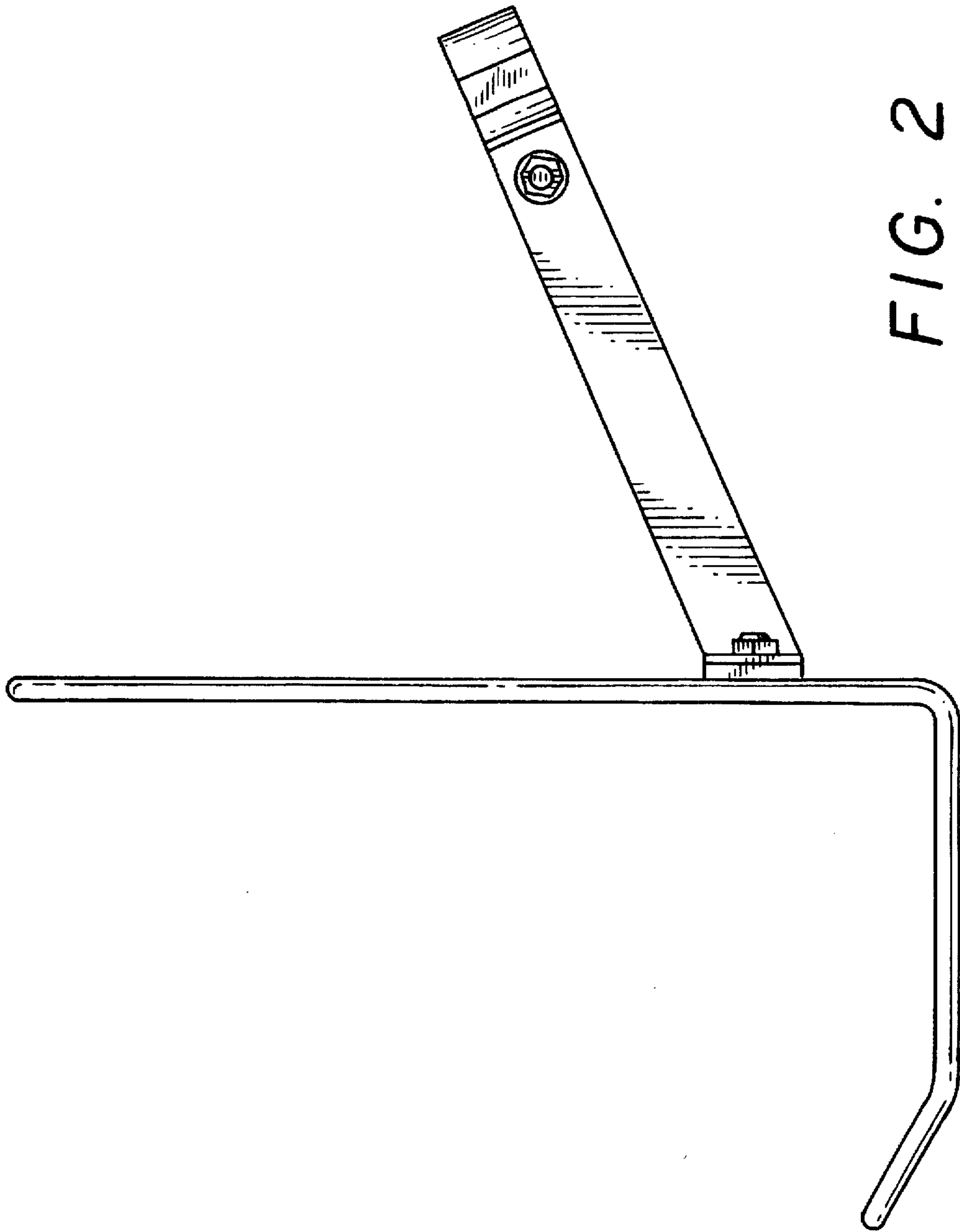

FIG. 1



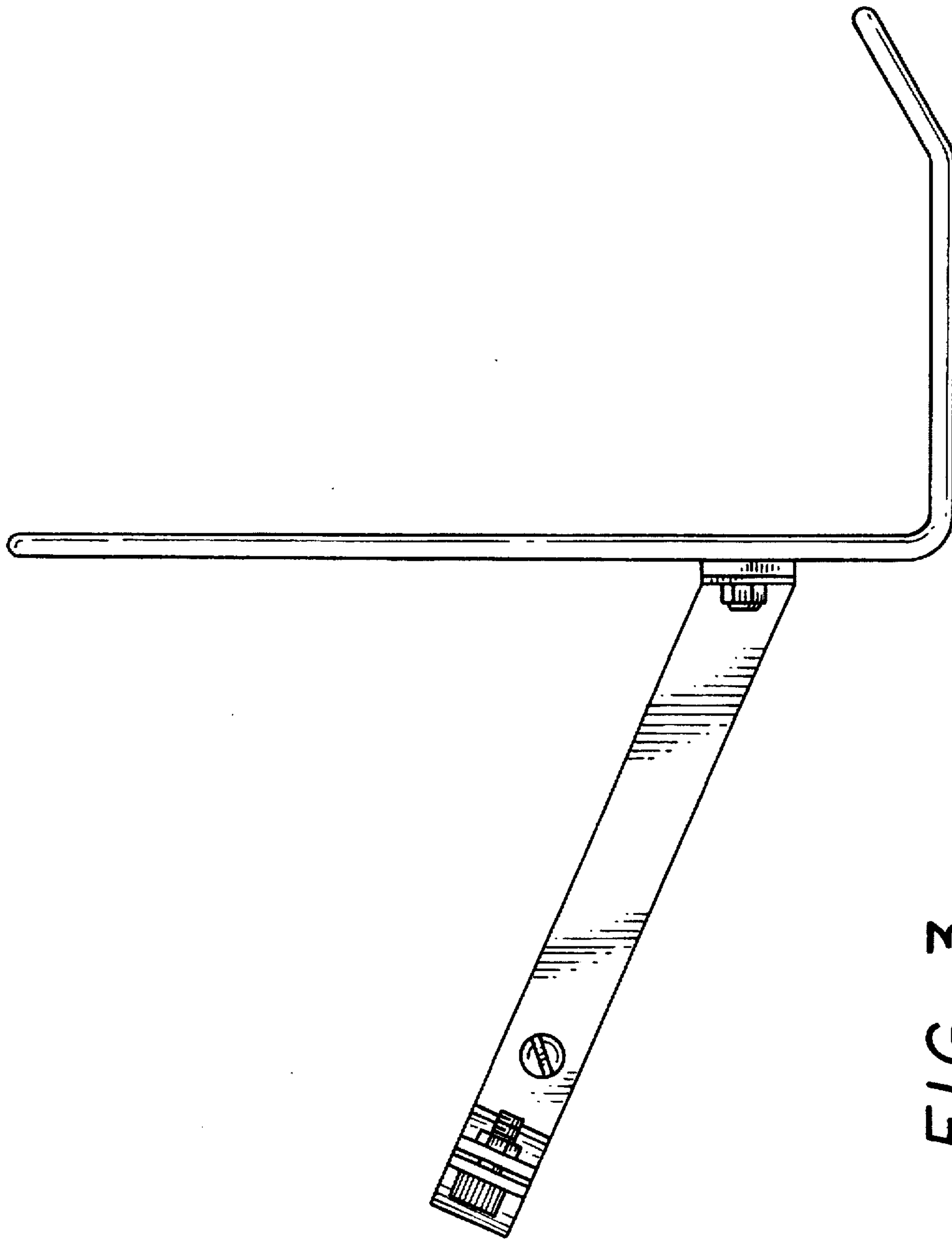

FIG. 3

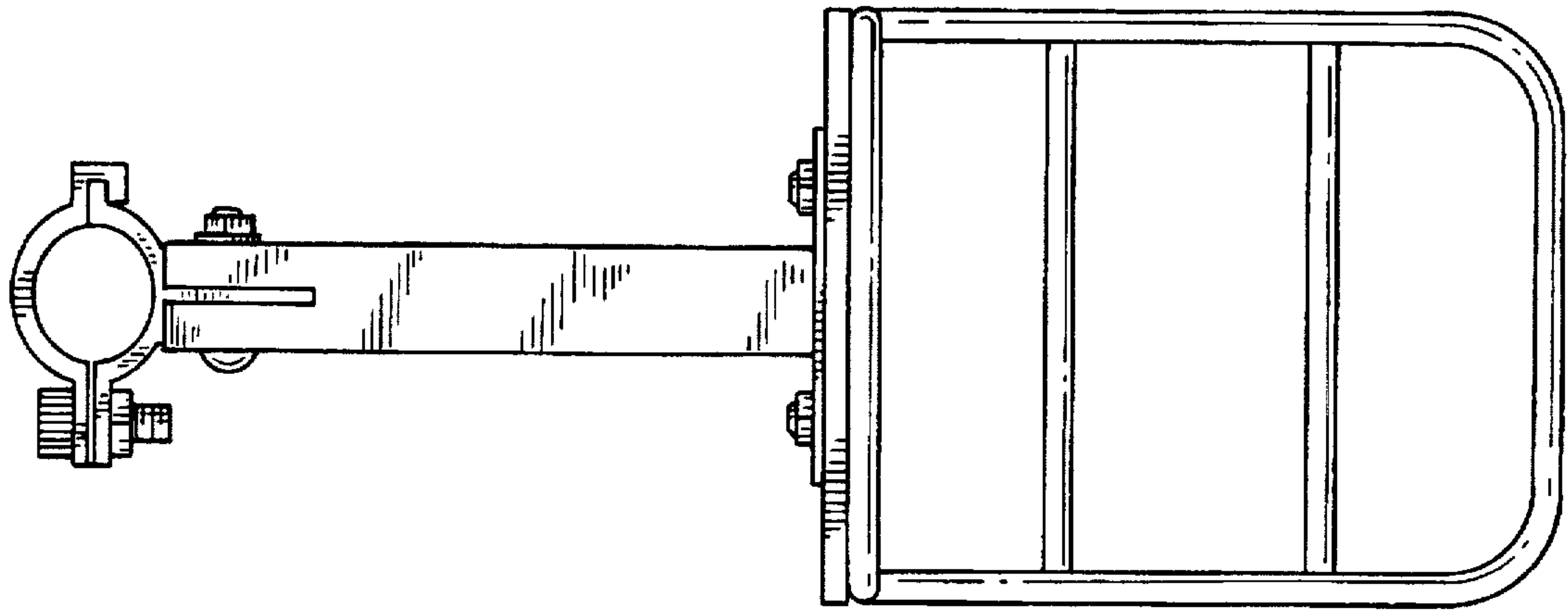

FIG. 5

FIG. 4

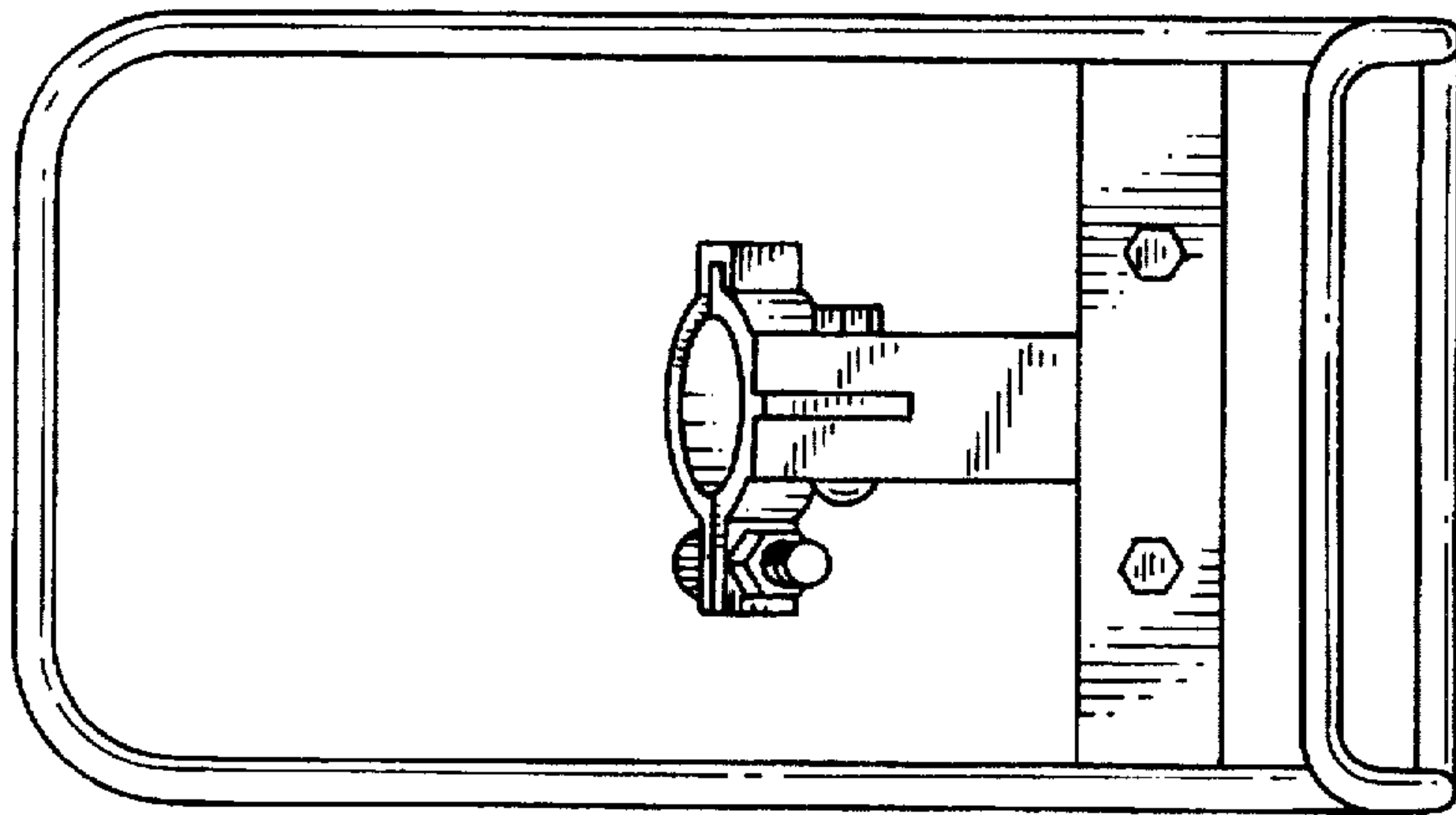

FIG. 6

