

US00D396864S

United States Patent [19]
Genz

[11] **Patent Number: Des. 396,864**
[45] **Date of Patent: **Aug. 11, 1998**

[54] **HYDRAULIC LIFT/ARMATURE ASSEMBLY FOR POWER LOG SPLITTER**

[76] **Inventor: Bruce W. Genz, 835 Avalon Rd., Janesville, Wis. 53546**

[**] **Term: 14 Years**

[21] **Appl. No.: 70,606**

[22] **Filed: May 12, 1997**

[51] **LOC (6) Cl. 15-09**

[52] **U.S. Cl. D15/127**

[58] **Field of Search** D15/127; 83/477.2, 83/574, 701, 928, 471.3, 471.2, 486.1, 468.1; 144/287, 286.5, 195.4; 269/1; 172/47; 37/231, 235, 125, 75, 272, 439; 180/53.1

[56] **References Cited**

U.S. PATENT DOCUMENTS

5,337,810	8/1994	McCormack	144/366 X
5,547,001	8/1996	Cumming et al.	144/195 A
5,575,319	11/1996	Chick	144/195.4

Primary Examiner—Antoine Duval Davis

[57] **CLAIM**

The ornamental design for a hydraulic lift/armature assembly for power log splitter, as shown and described.

DESCRIPTION

FIG. 1 is a front elevational view of a hydraulic lift/armature assembly for power log splitter showing my new design; FIG. 2 is a top elevational plan view thereof; FIG. 3 is a bottom elevational view thereof; FIG. 4 is a front elevational plan view of FIG. 1 showing the lift/armature in a condition of use thereof; FIG. 5 is left side elevational plan view thereof; FIG. 6 is a right side elevational plan view thereof; FIG. 7 is a front elevational view thereof showing the lift/armature in placement on the side rest thereof; FIG. 8 is a top elevational plan view in FIG. 7 showing the lift/armature in placement on the side rest thereof; FIG. 9 is a modified front elevational plan view of FIG. 1, as a hydraulic lift/armature assembly for power log splitter showing my new design; FIG. 10 is a top side elevational plan view thereof; FIG. 11 is a bottom side elevational plan view thereof; FIG. 12 is a front elevational plan view of the hydraulic lift/armature as in FIG. 9 in a condition of use thereof; FIG. 13 is a left side elevational plan view thereof; and, FIG. 14 is a right side elevational plan view thereof.

The broken line of the "power log splitter and wheel" in FIGS. 1, 4, 7, 9 and 12 is for illustrative purposes only and forms no part of the claimed design; and, The rear side of FIGS. 1, 4, 7, 9 and 12 are mirror images of their respective figure drawings thereof.

1 Claim, 5 Drawing Sheets

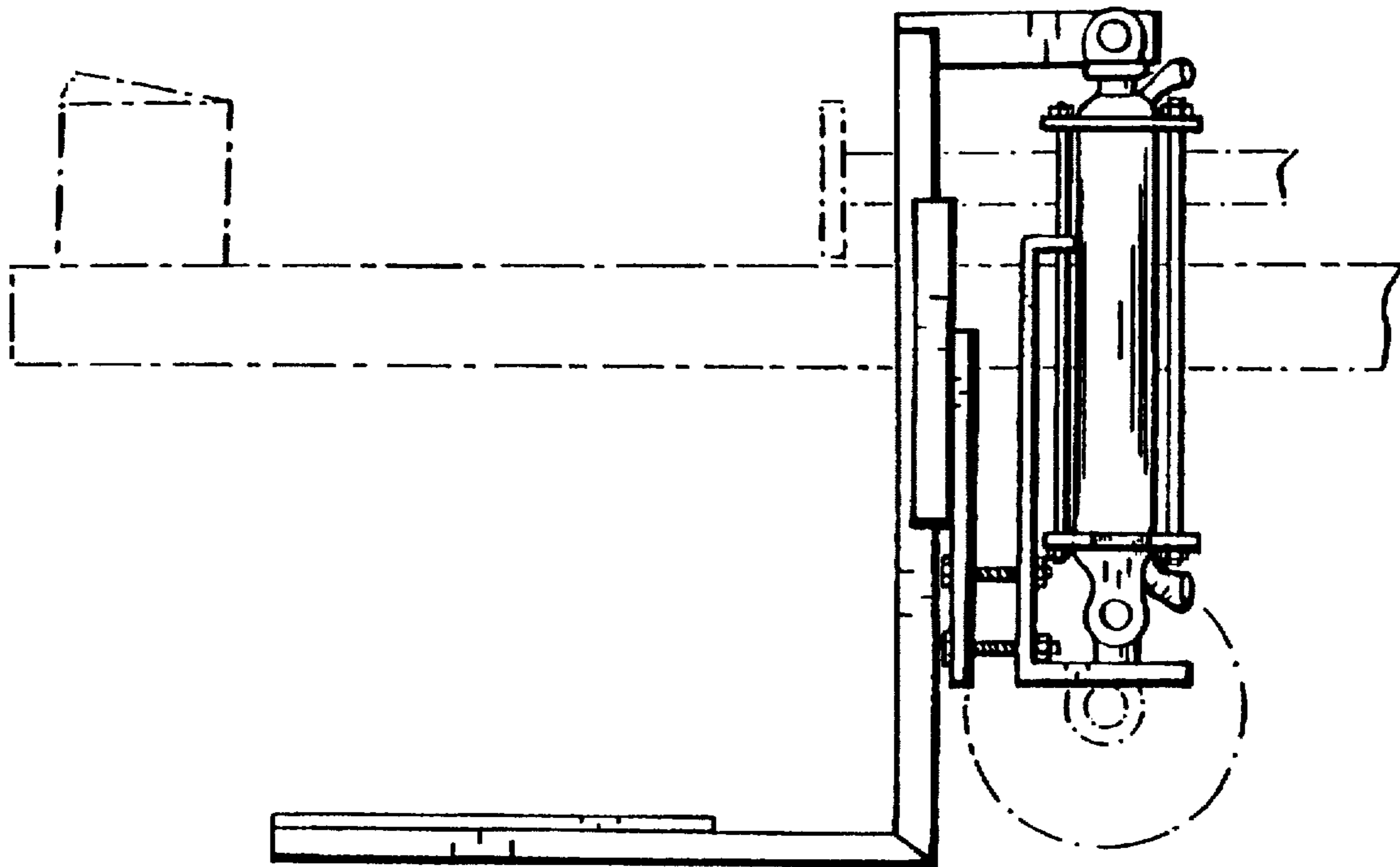

FIG. 1

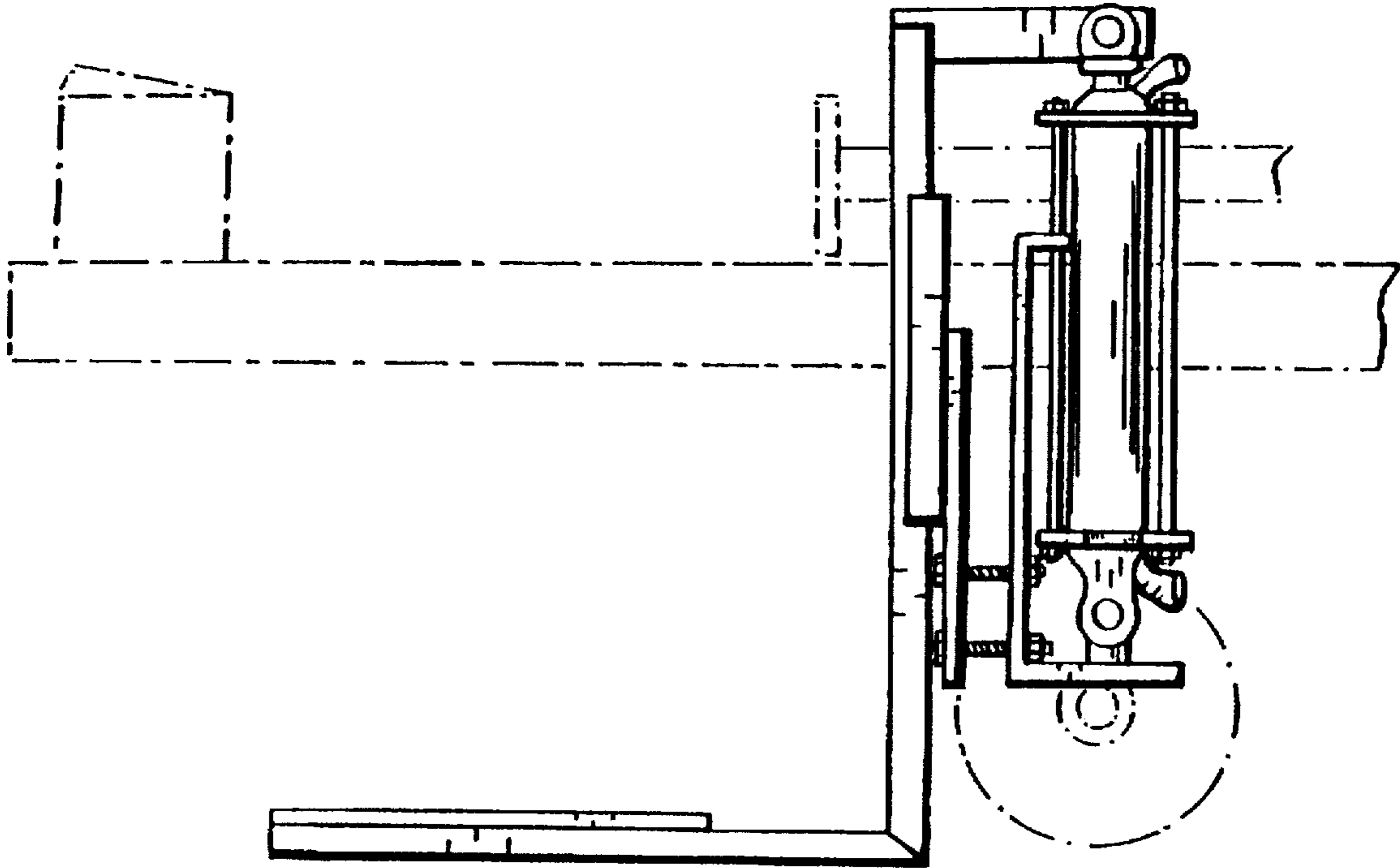

FIG. 2

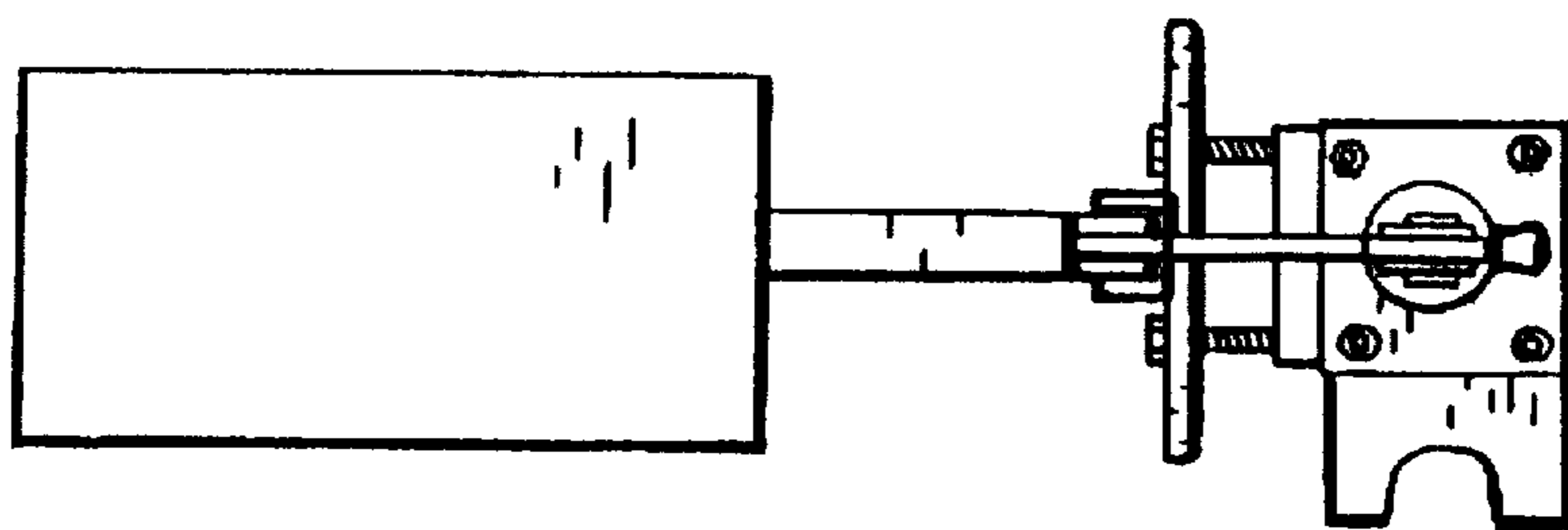

FIG. 3

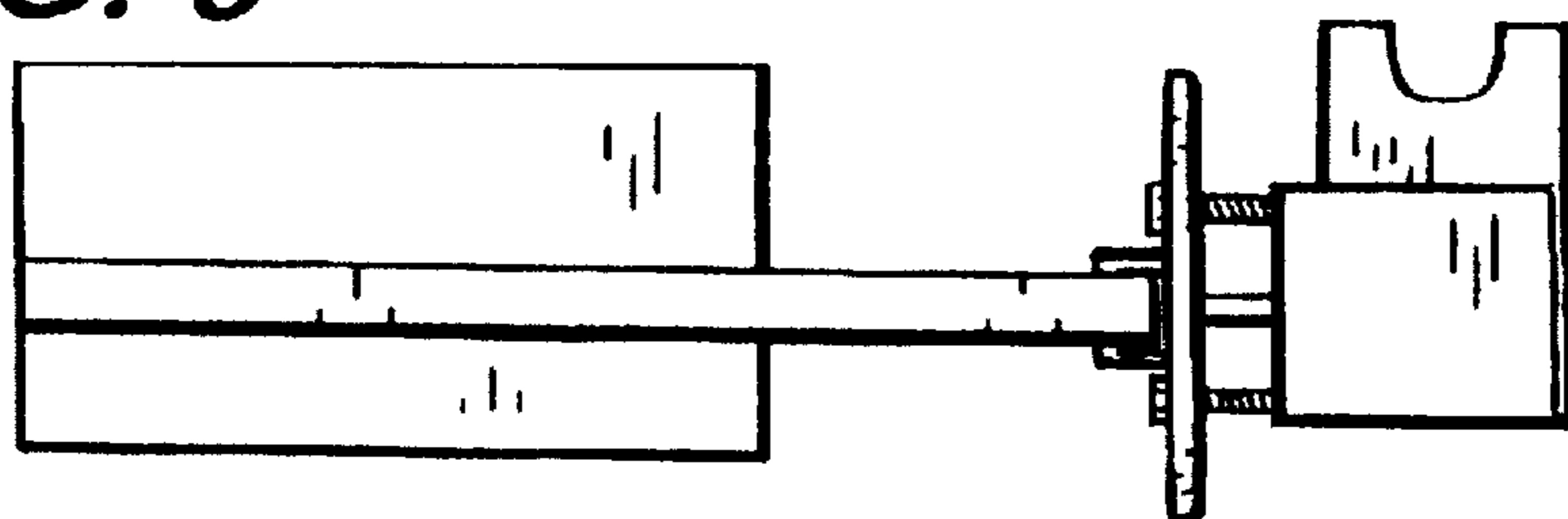

FIG. 4

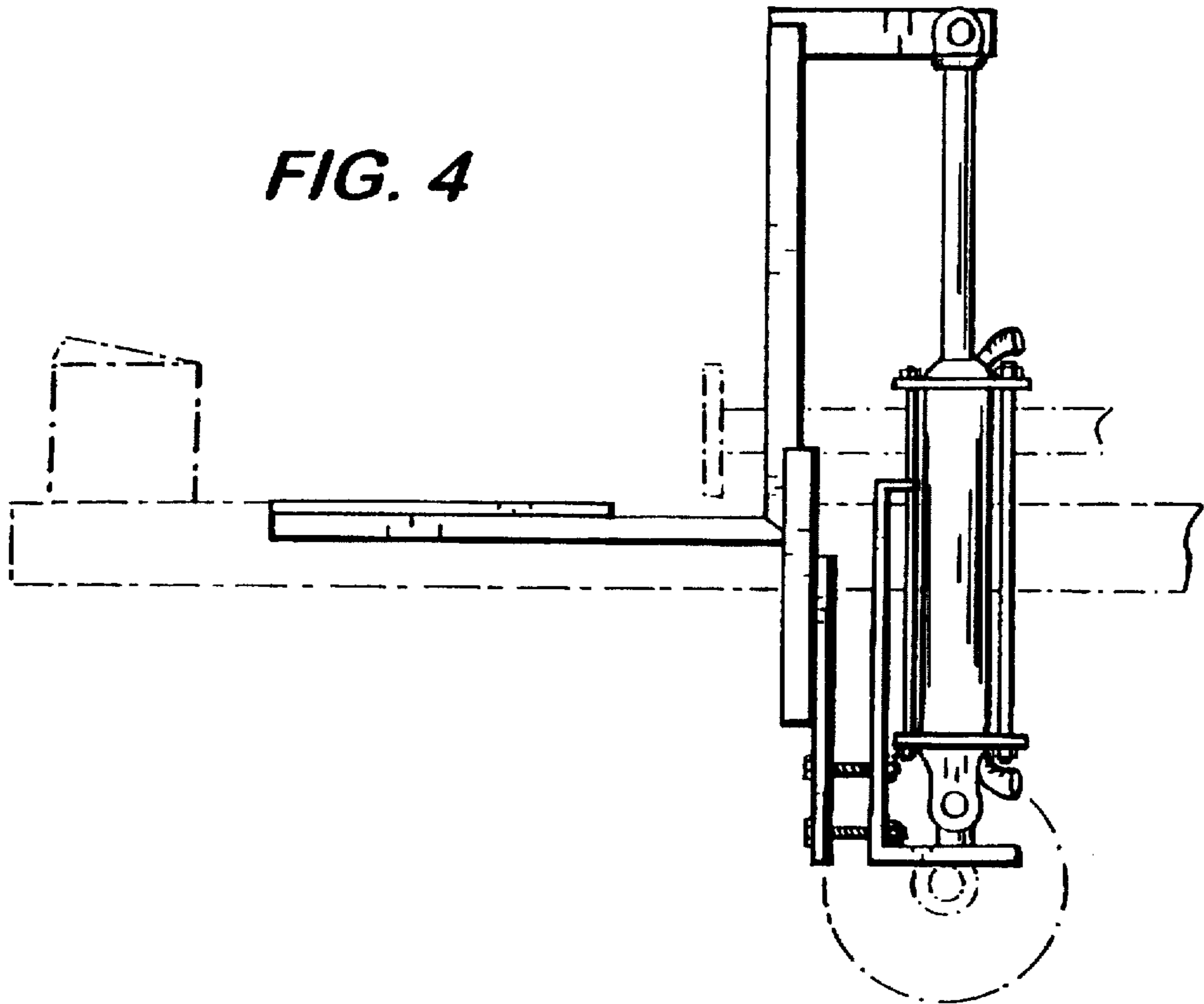

FIG. 5

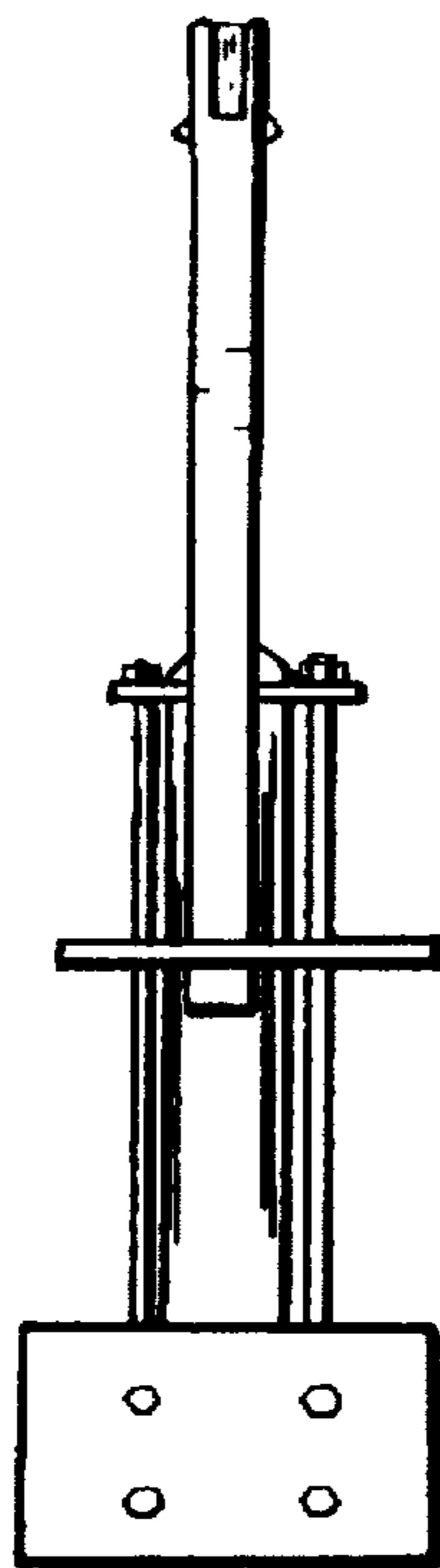

FIG. 6

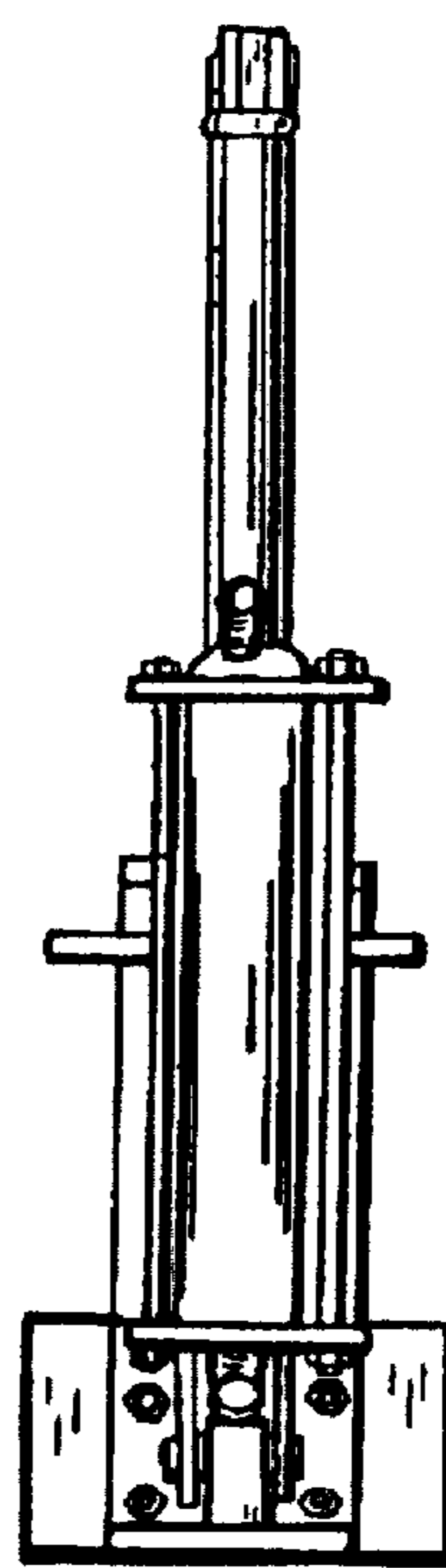

FIG. 7

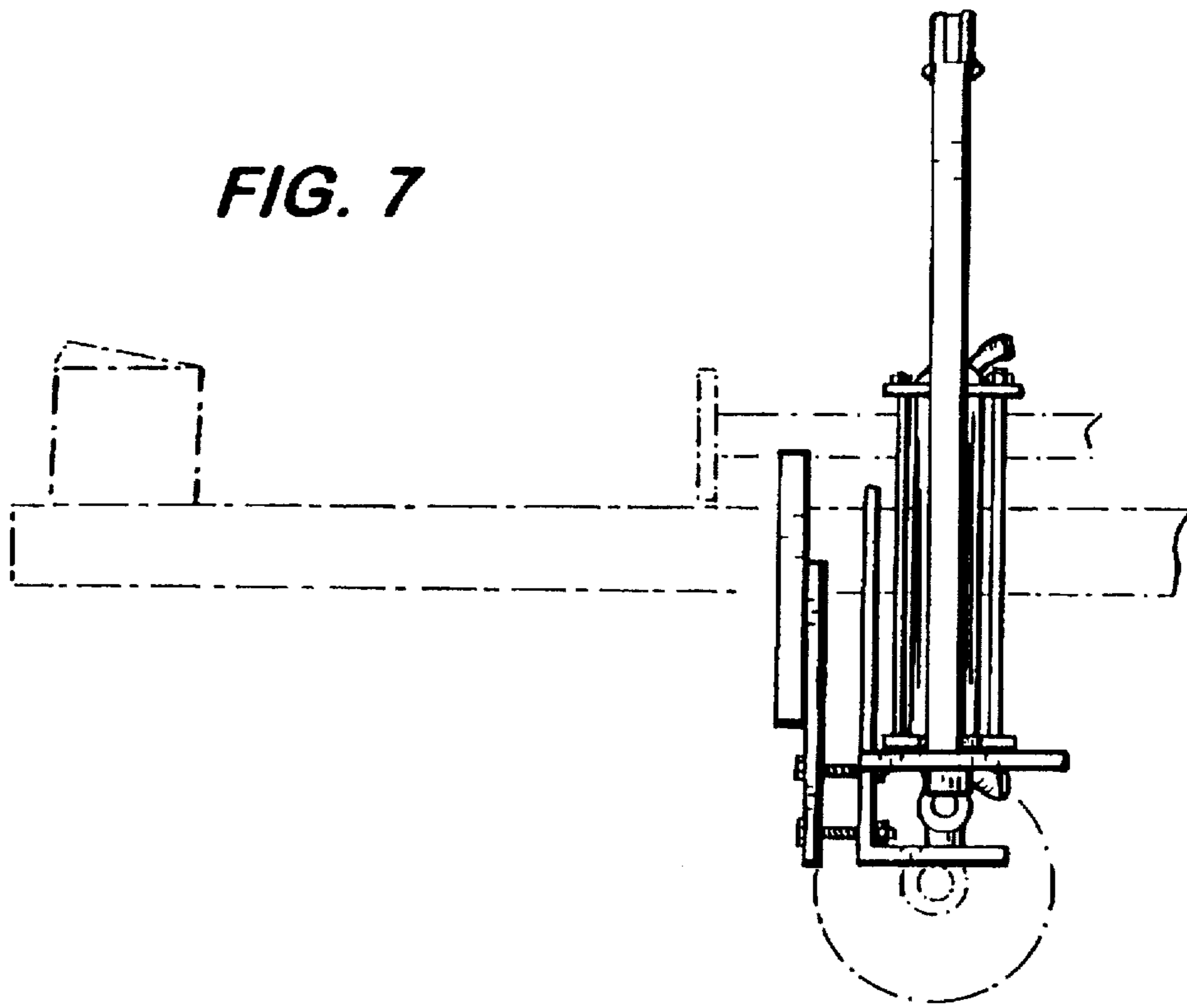

FIG. 8

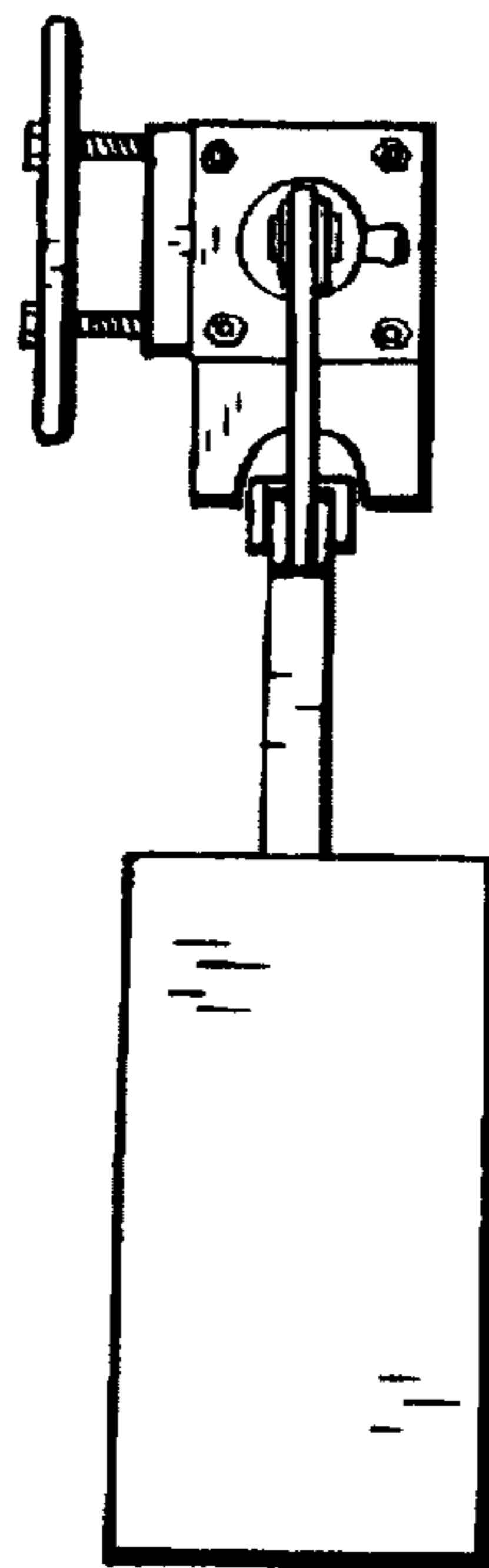

FIG. 9

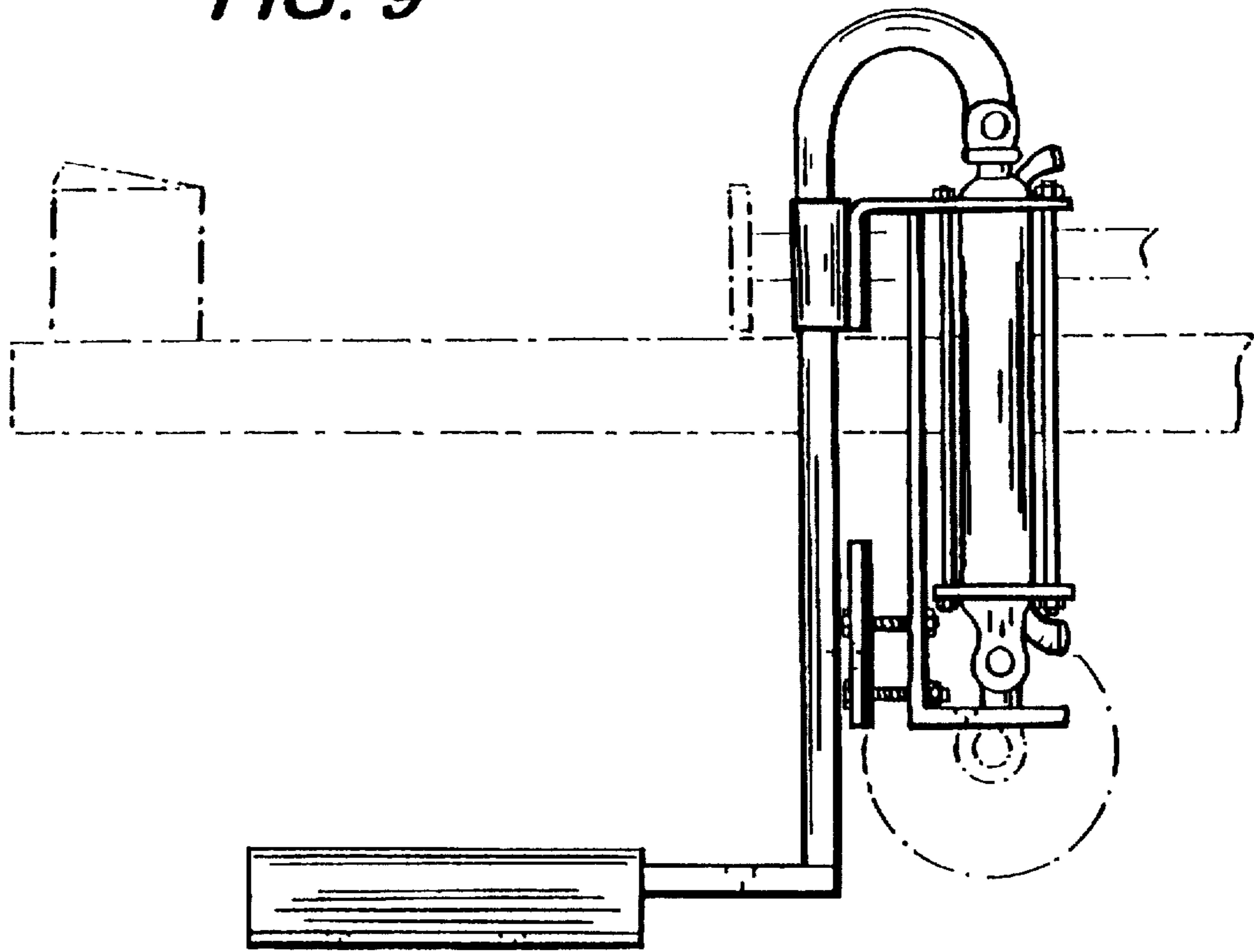

FIG. 10

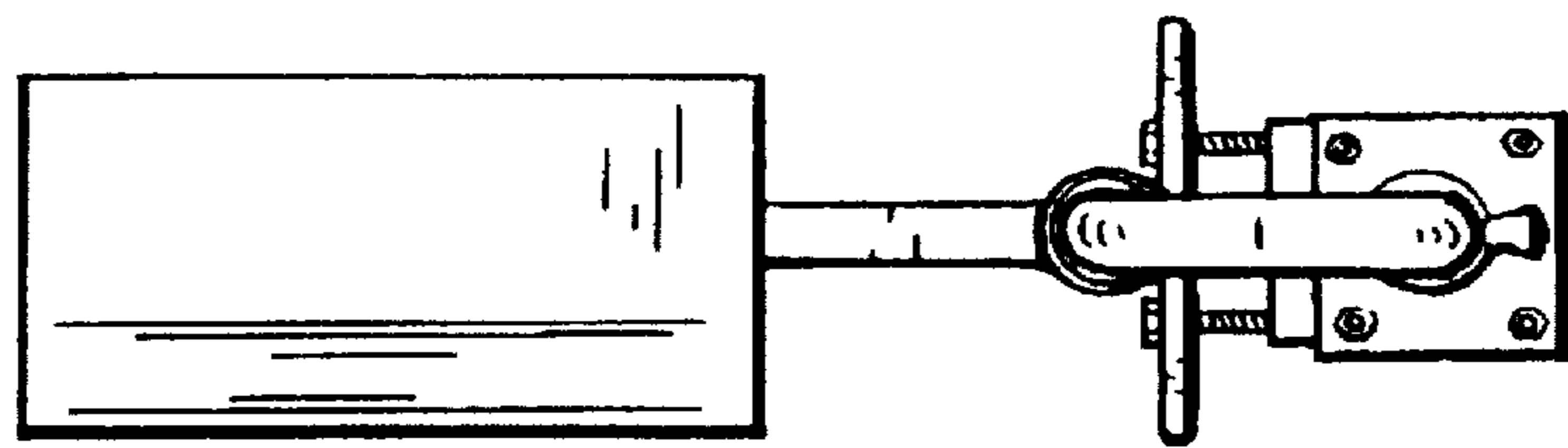

FIG. 11

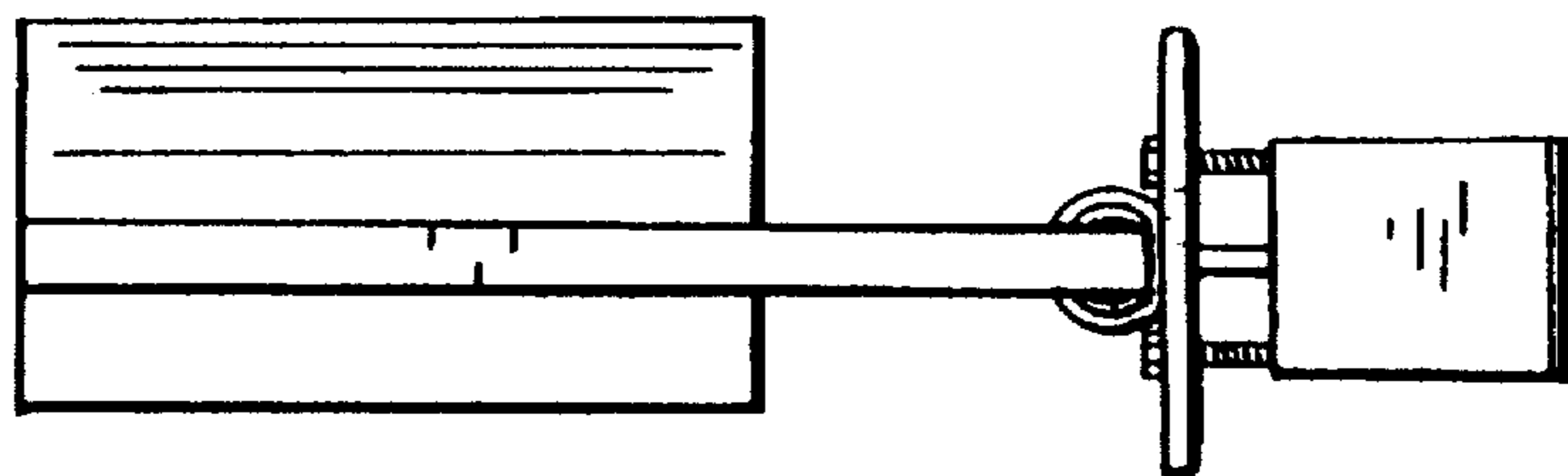

FIG. 12

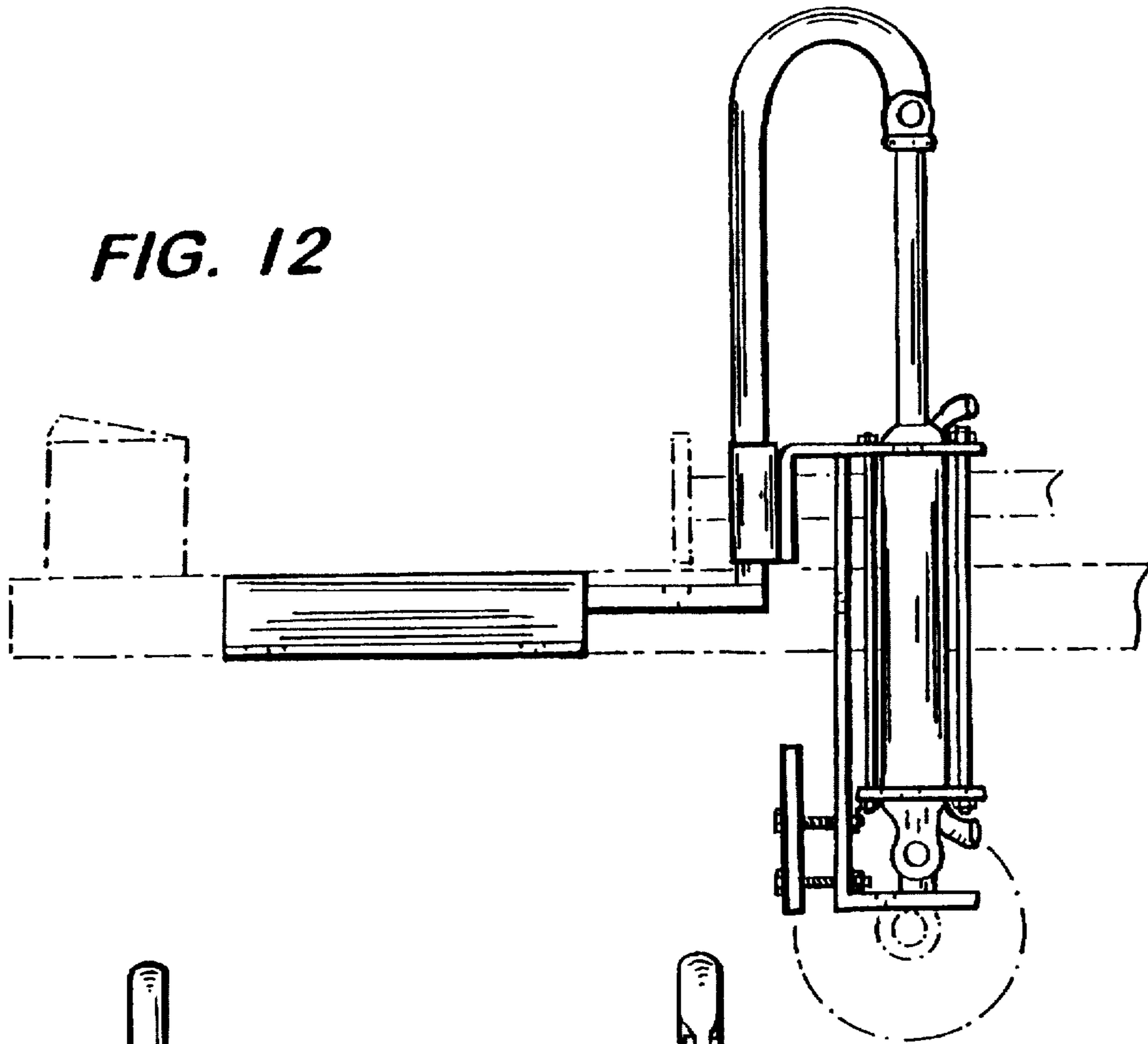

FIG. 13

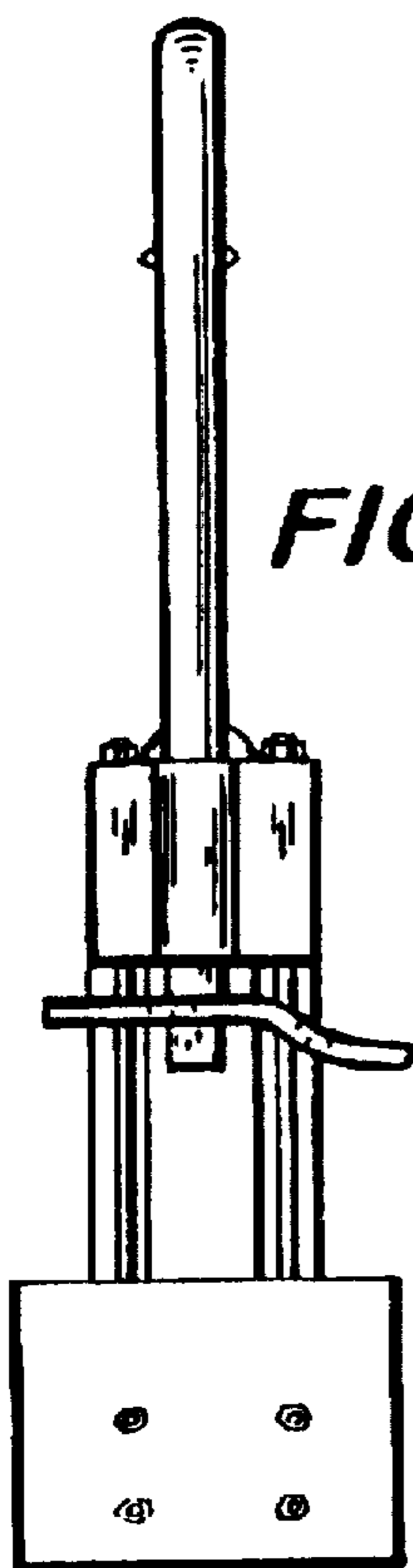

FIG. 14

