



US00D396842S

**United States Patent** [19]  
**Jones**

[11] **Patent Number: Des. 396,842**

[45] **Date of Patent: \*\*Aug. 11, 1998**

[54] **AIRCRAFT**

[76] **Inventor: Steven Lonnie Jones, 989 Victoria #A-5, Costa Mesa, Calif. 92627**

[\*\*] **Term: 14 Years**

[21] **Appl. No.: 51,066**

[22] **Filed: Mar. 22, 1996**

**Related U.S. Application Data**

[63] **Continuation-in-part of Ser. No. 26,376, Sep. 14, 1994, Pat. No. Des. 371,536.**

[51] **LOC (6) Cl. .... 21-07**

[52] **U.S. Cl. .... D12/333; D12/344**

[58] **Field of Search .... D12/129-145; 244/13, 215, 220, 35 R, 36, 56, 55, 199; D21/87**

[56] **References Cited**

**U.S. PATENT DOCUMENTS**

D. 117,419 10/1939 Munk et al. .... D12/333  
D. 371,536 7/1996 Jones ..... D12/333

2,406,506 8/1946 Northrop ..... 244/13  
2,406,588 8/1946 Cornelius ..... 244/13  
4,739,957 4/1988 Vess et al. .... 244/199

*Primary Examiner*—Kay H. Chin

[57] **CLAIM**

The ornamental design for a aircraft, as shown and described.

**DESCRIPTION**

FIG. 1 is a front elevational view of an aircraft showing my new design;  
FIG. 2 is a front elevational view thereof in parked condition;  
FIG. 3 is a side elevational view of FIG. 1, the opposite side view being a mirror image of that shown;  
FIG. 4 is a side elevational view of FIG. 2;  
FIG. 5 is a top plan view thereof;  
FIG. 6 is a bottom plan view thereof;  
FIG. 7 is a side elevational view thereof in climb-out condition;  
FIG. 8 is a top perspective view thereof; and  
FIG. 9 is a bottom perspective view thereof.

**1 Claim, 6 Drawing Sheets**

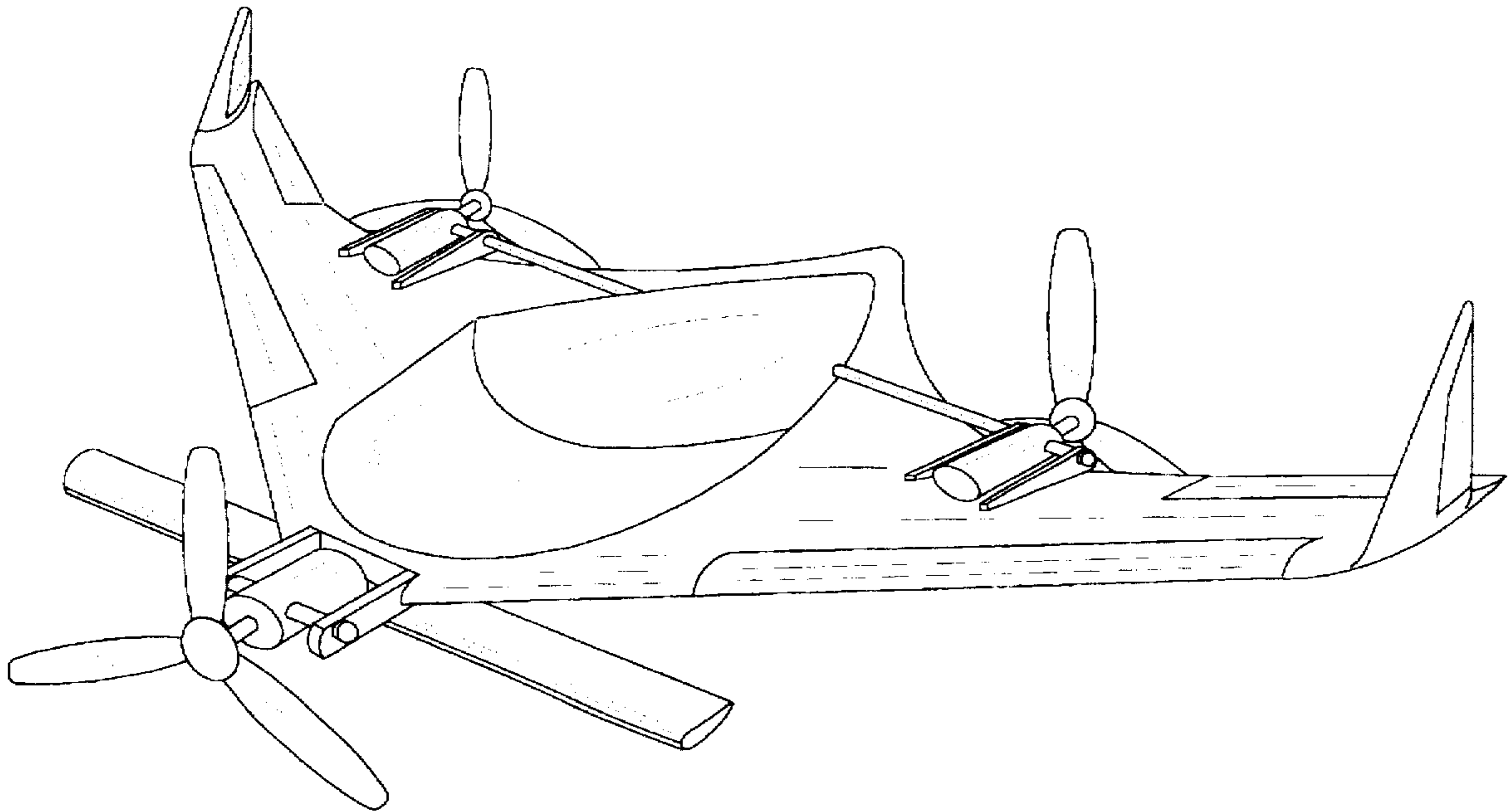

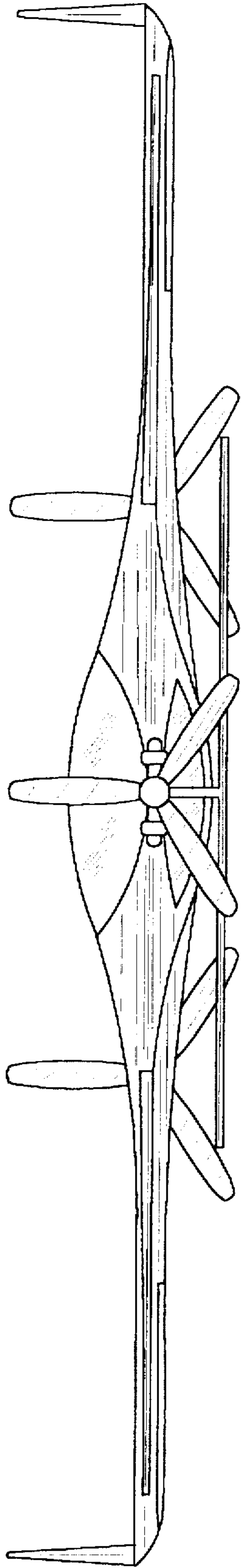

Fig. 1

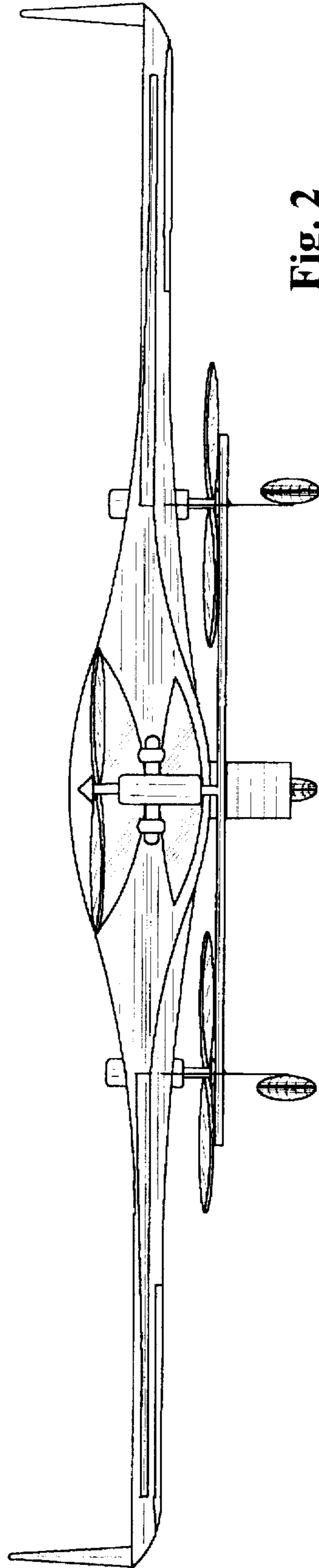

Fig. 2

Fig. 3

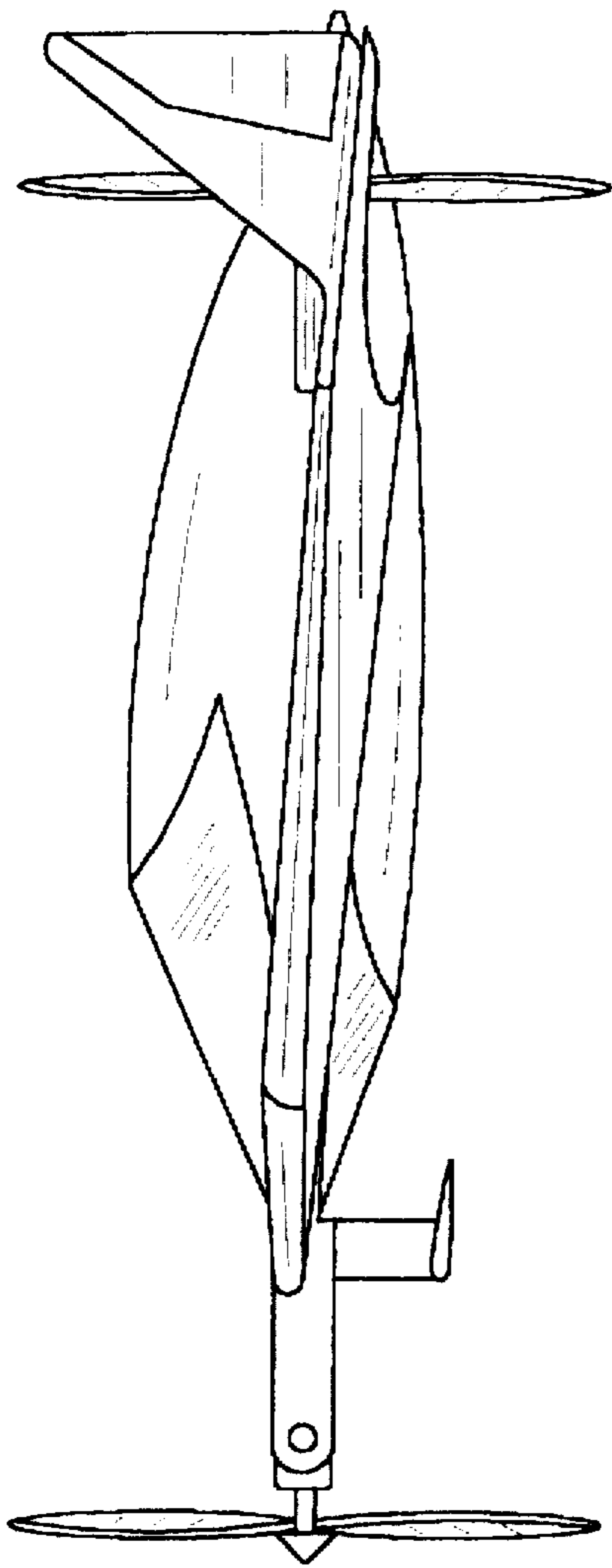
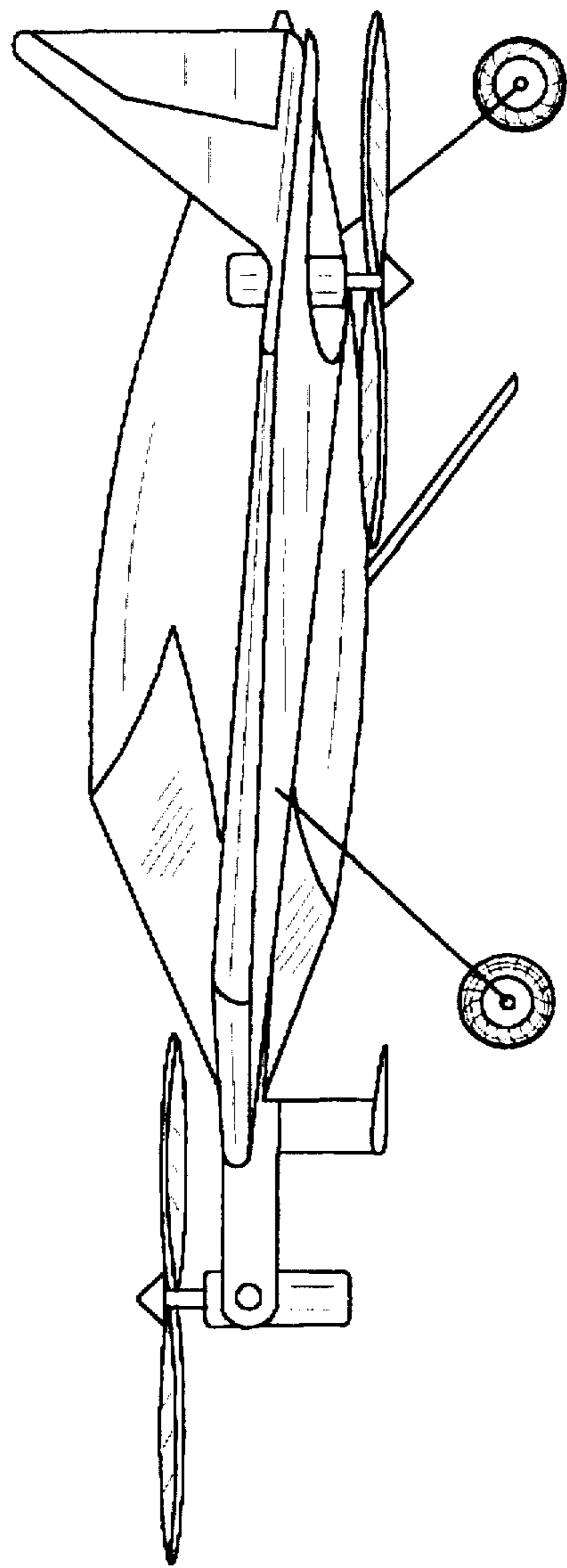

Fig. 4



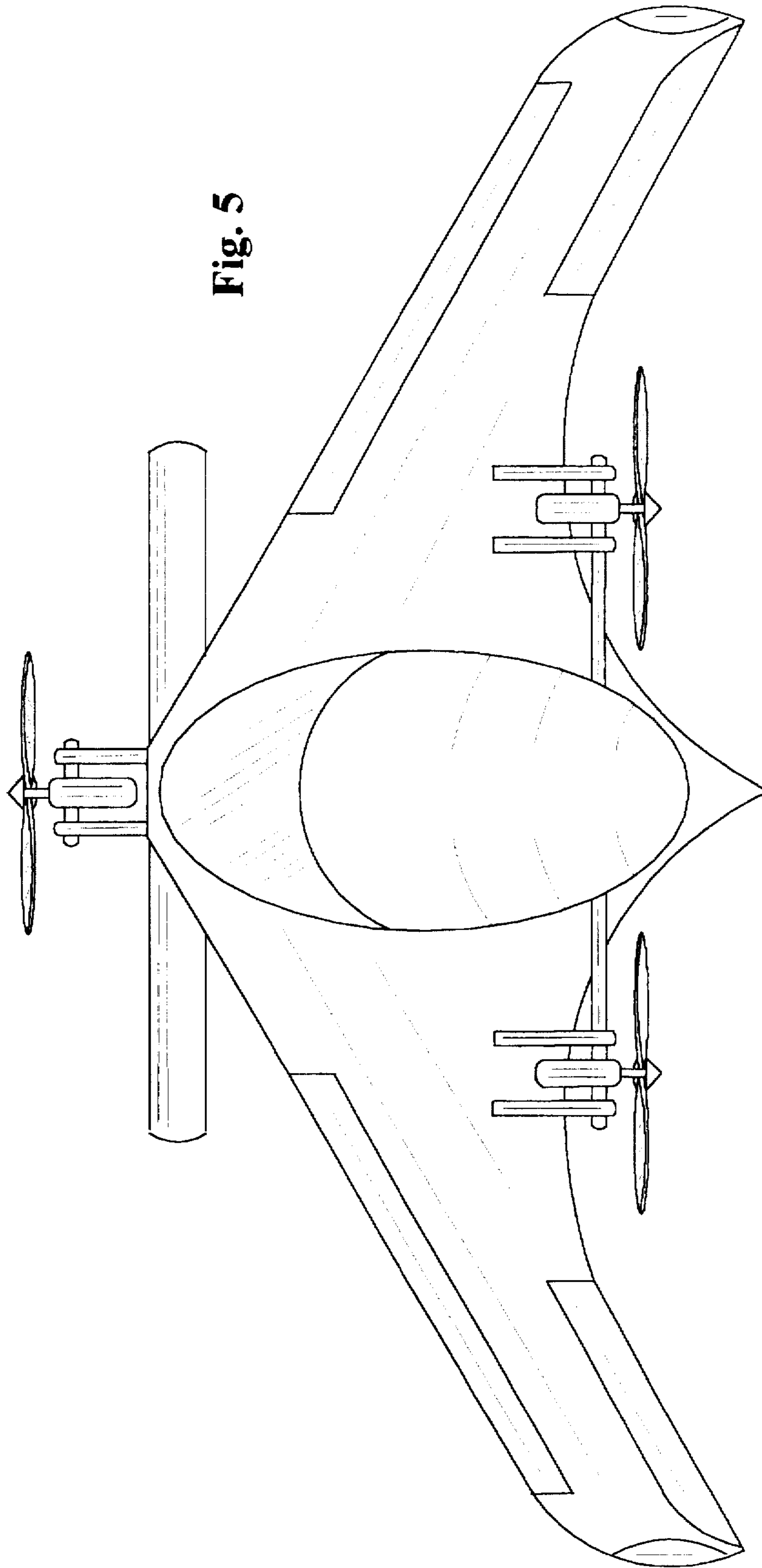
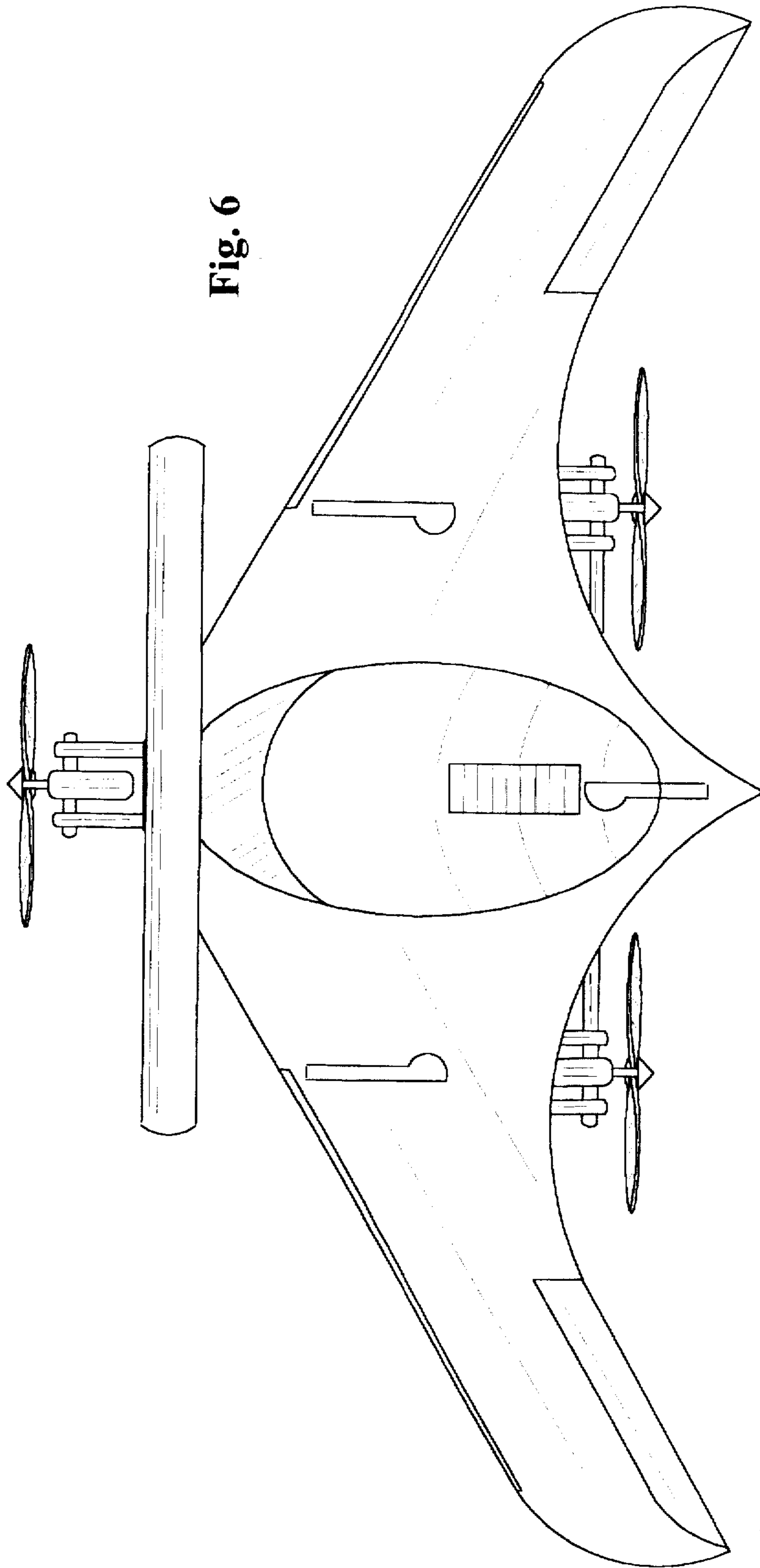

Fig. 5





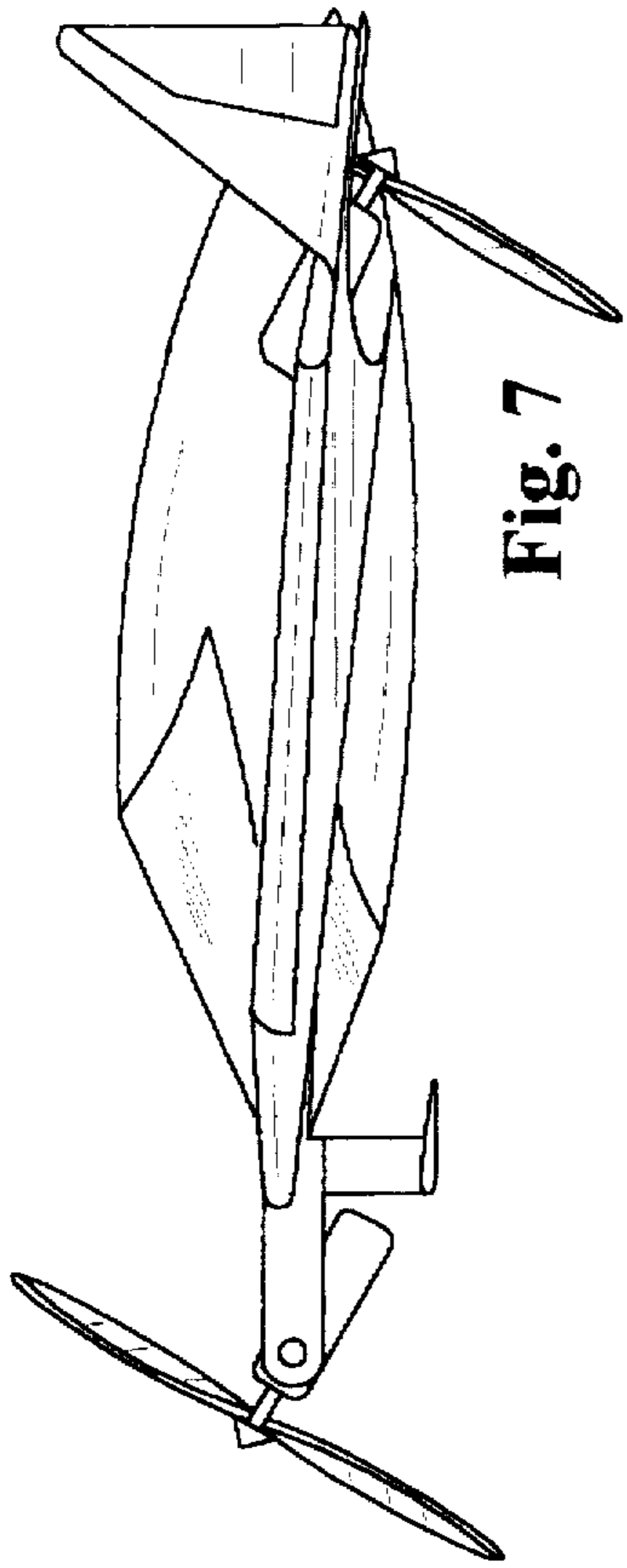

Fig. 7

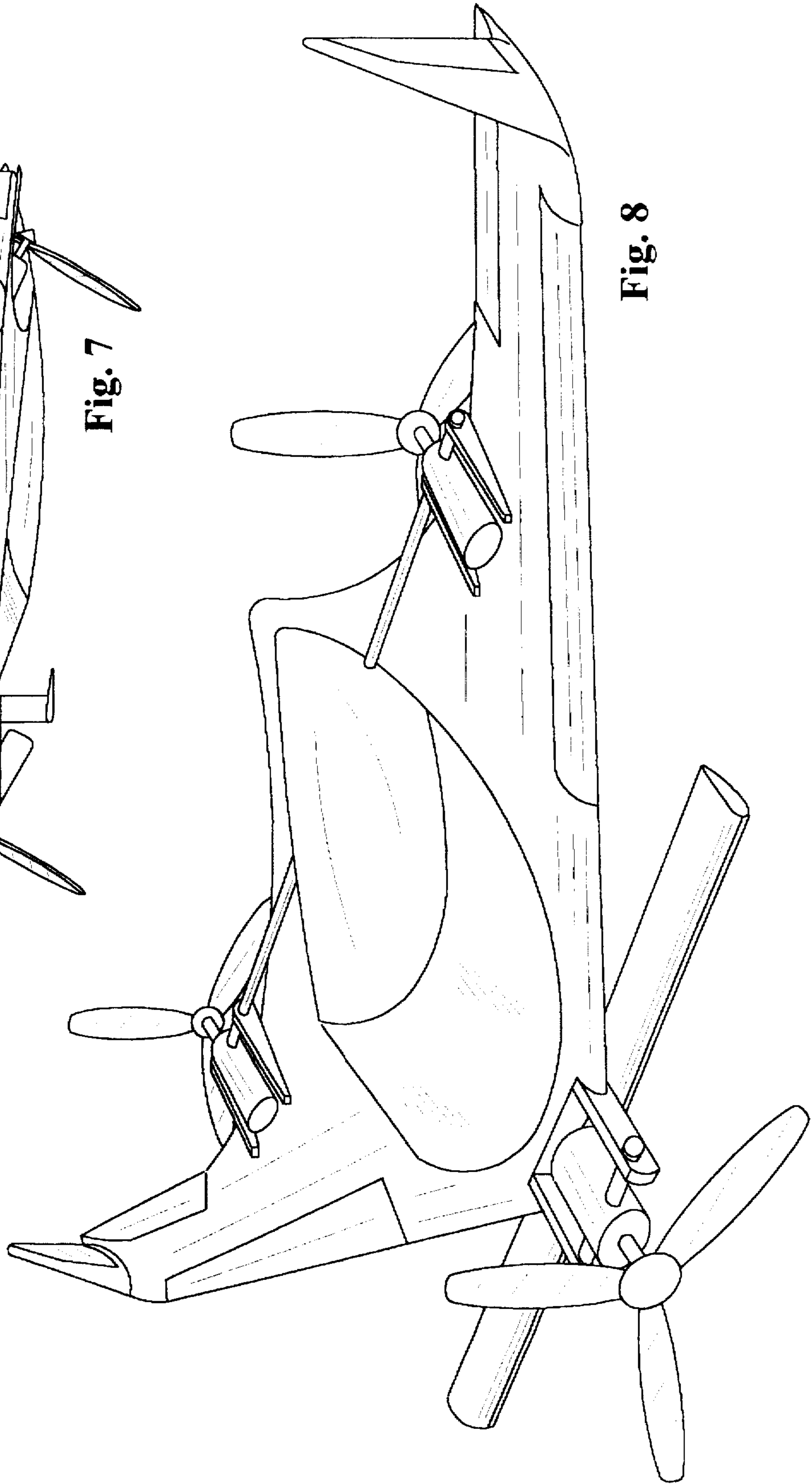

Fig. 8

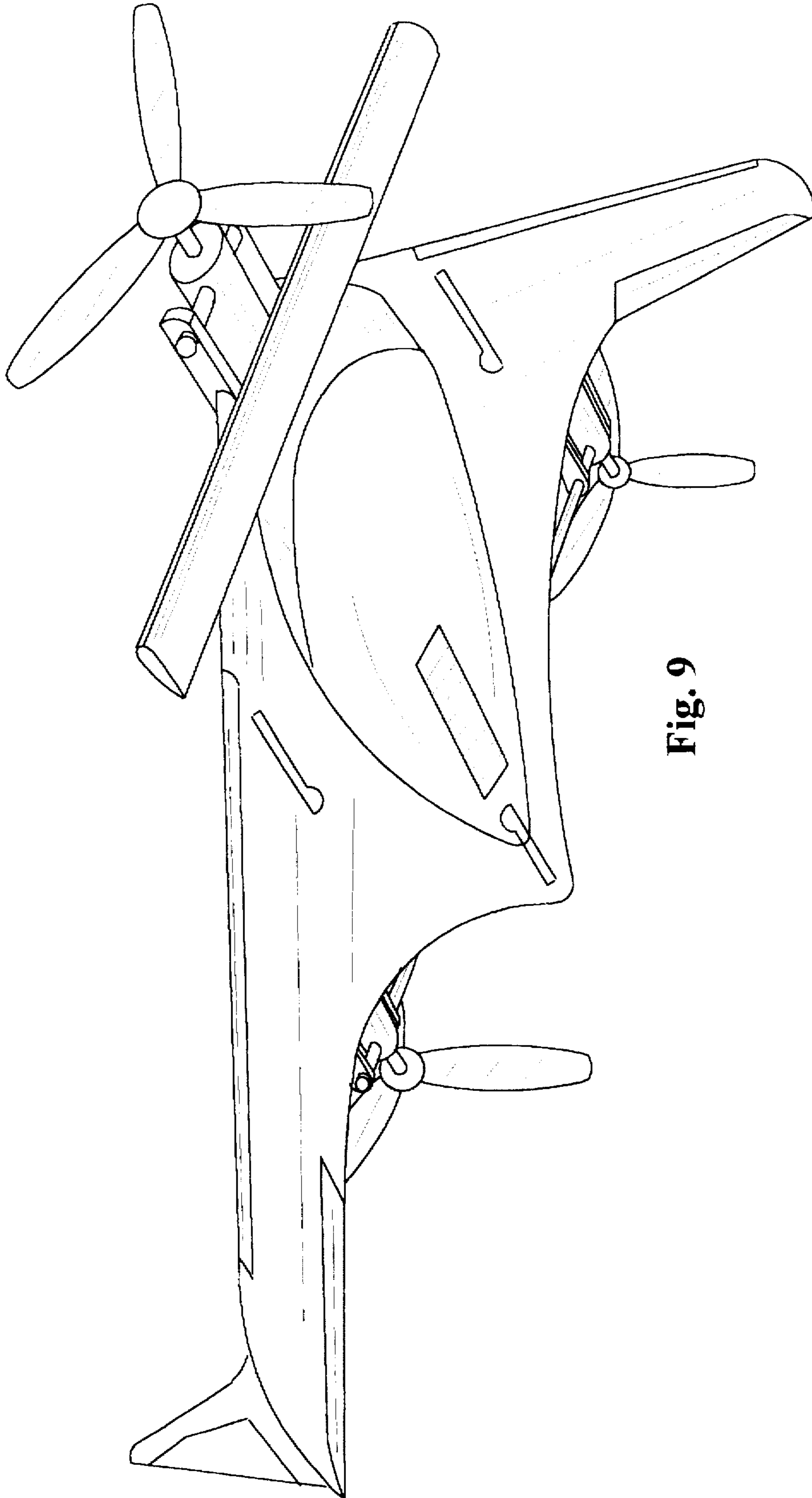

Fig. 9