

US00D396727S

# United States Patent [19]

Geier et al.

[11] Patent Number: **Des. 396,727**

[45] Date of Patent: **\*\*Aug. 4, 1998**

[54] **RIDING ROLLER**

[75] Inventors: **Daniel S. Geier**, Colgate; **Ronald W. Brinkmann**, Hartford; **Frederich H. Knoch**, Racine; **Thomas Green**, West Bend, all of Wis.

[73] Assignee: **Wacker Corporation**, Menomonee Falls, Wis.

[\*\*] Term: **14 Years**

[21] Appl. No.: **74,410**

[22] Filed: **Aug. 1, 1997**

[51] LOC (6) Cl. .... **15-04**

[52] U.S. Cl. .... **D15/20**

[58] Field of Search ..... **D15/10, 20, 22, D15/23; 180/20, 89.12; 404/122, 125**

[56] **References Cited**

**U.S. PATENT DOCUMENTS**

D. 185,841	8/1959	Schertzer	.....	D15/20
D. 207,532	5/1967	Garis et al.	.....	D15/20
D. 275,678	9/1984	Mawhorr et al.	.....	D15/20
4,162,862	7/1979	Harker et al.	.....	404/122
4,266,884	5/1981	Tuneblom	.....	404/122

**OTHER PUBLICATIONS**

Ammann "Tandem-Vibrationswalzen" showing Models DTV 112, DTV 113, DTV 132, DTV 133 and DVK 153 Brochure consisting of 2 pages. Undated.

Ammann "A V-Serie Vibrationswalzen 2.3 -3.3 t" showing Models AV23, AV26, AV32, AV33 and AV23K, AV26K, and AV32K Brochure consisting of 2 pages. Undated.

CAT® Tandem-Vibrationswalzen showing Models CB-214C and CB-224C Brochure consisting of 3 pages. Undated.

Svedala, Dynapac Brochure showing Models CC 102C/122C Combi-Roller consisting of 2 pages. Undated.

Stone® WolfPac™ Rollers Brochure showing Models 2500, 3100, and 4000, 1995, consisting of 6 pages. Undated. Form Magazine, p. 43, Roller, Apr. 1978.

*Primary Examiner*—Sandra L. Morris

*Attorney, Agent, or Firm*—Nilles & Nilles, S.C.

[57] **CLAIM**

The ornamental design for a riding roller, as shown and described.

**DESCRIPTION**

FIG. 1 is a perspective view of a riding roller incorporating our new design as viewed from above, from in front of, and from the left side of the riding roller;

FIG. 2 is a perspective view of the riding roller of FIG. 1 as viewed from below, from in front of, and from the left side thereof;

FIG. 3 is a front elevation view of the riding roller;

FIG. 4 is a rear elevation view of the riding roller;

FIG. 5 is a left-side elevation view of the riding roller;

FIG. 6 is a right-side elevation view of the riding roller; and,

FIG. 7 is a top plan view of the riding roller.

**1 Claim, 7 Drawing Sheets**

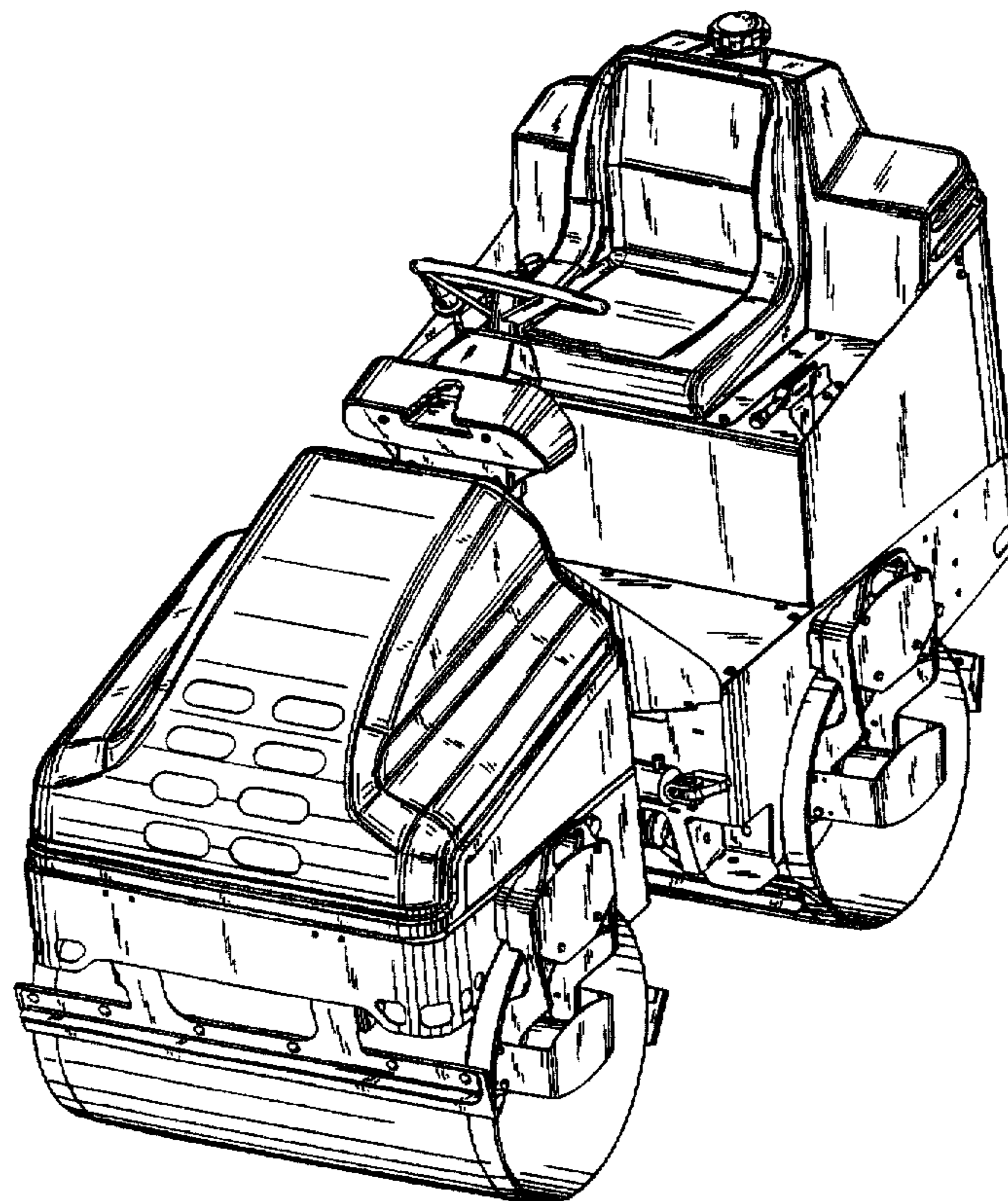

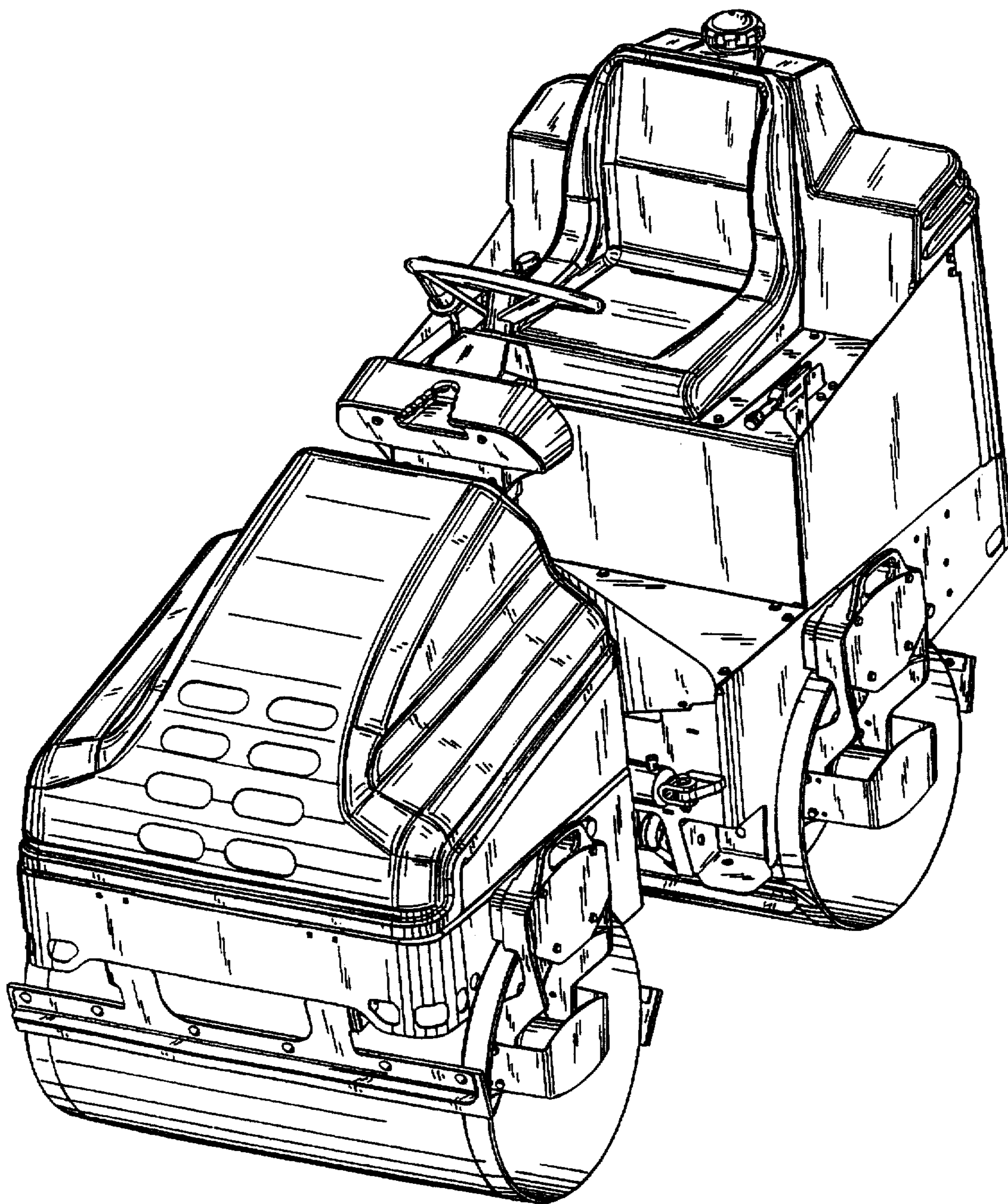

FIG. 1

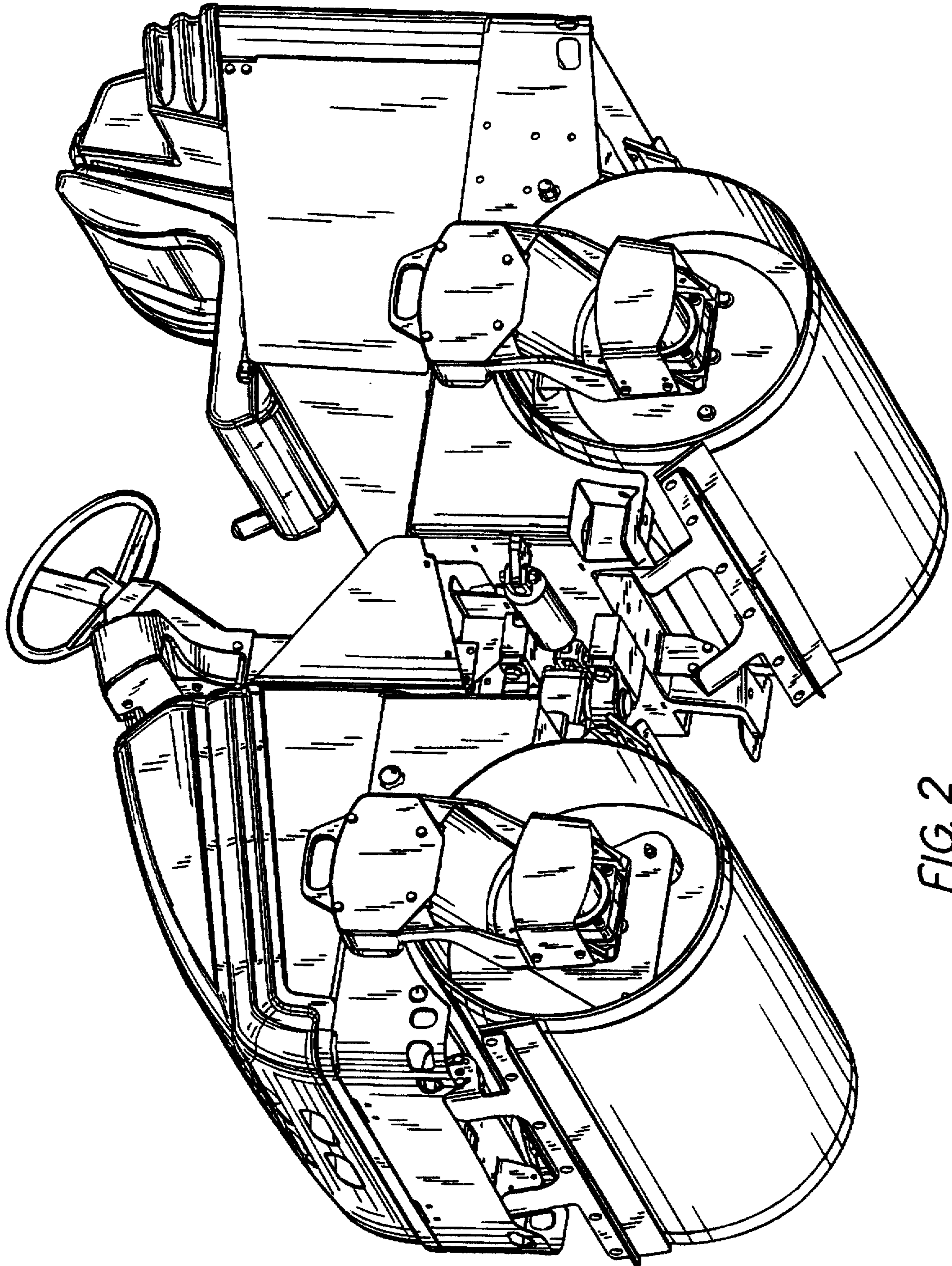

FIG. 2

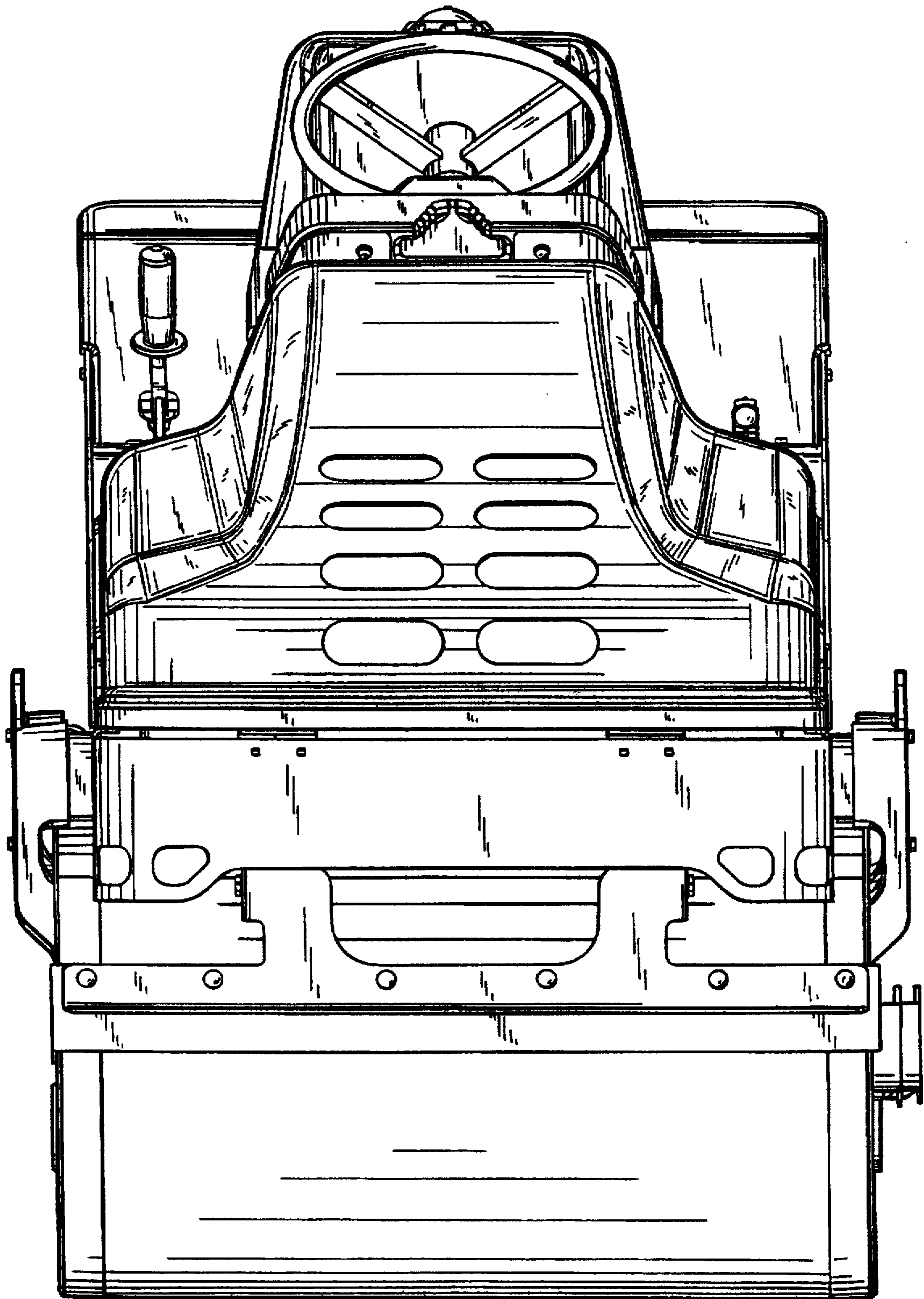

FIG. 3

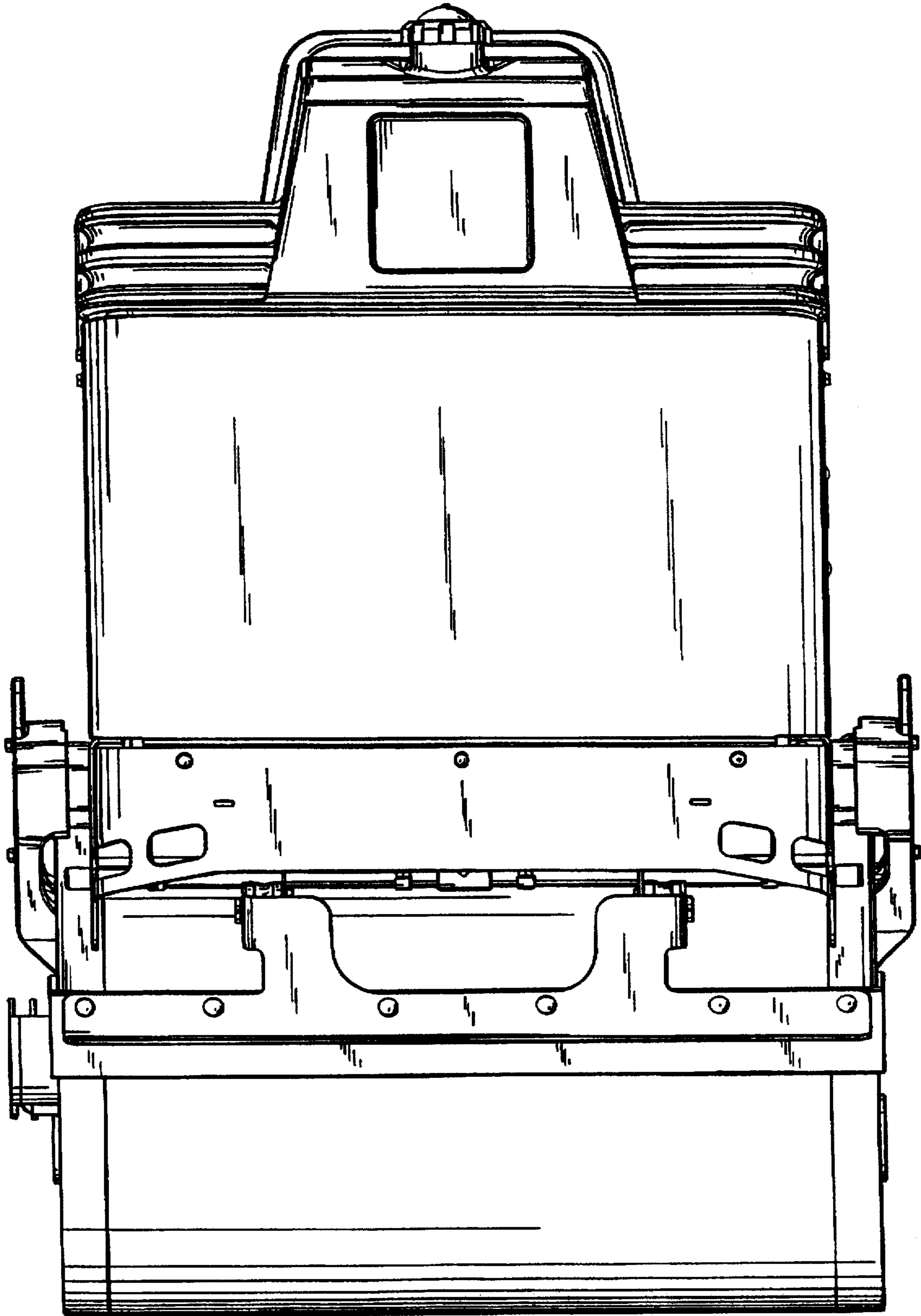

FIG. 4

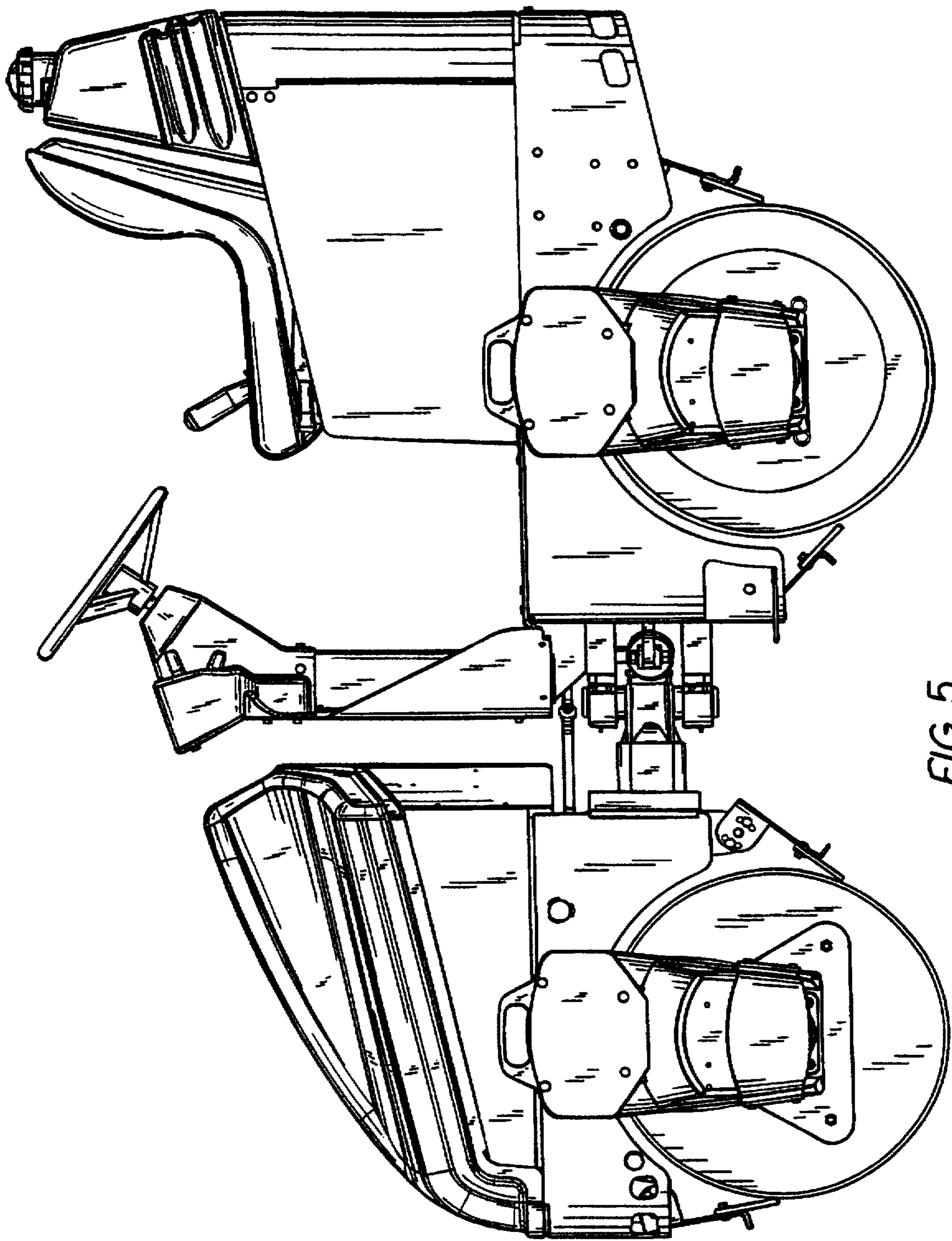

FIG. 5

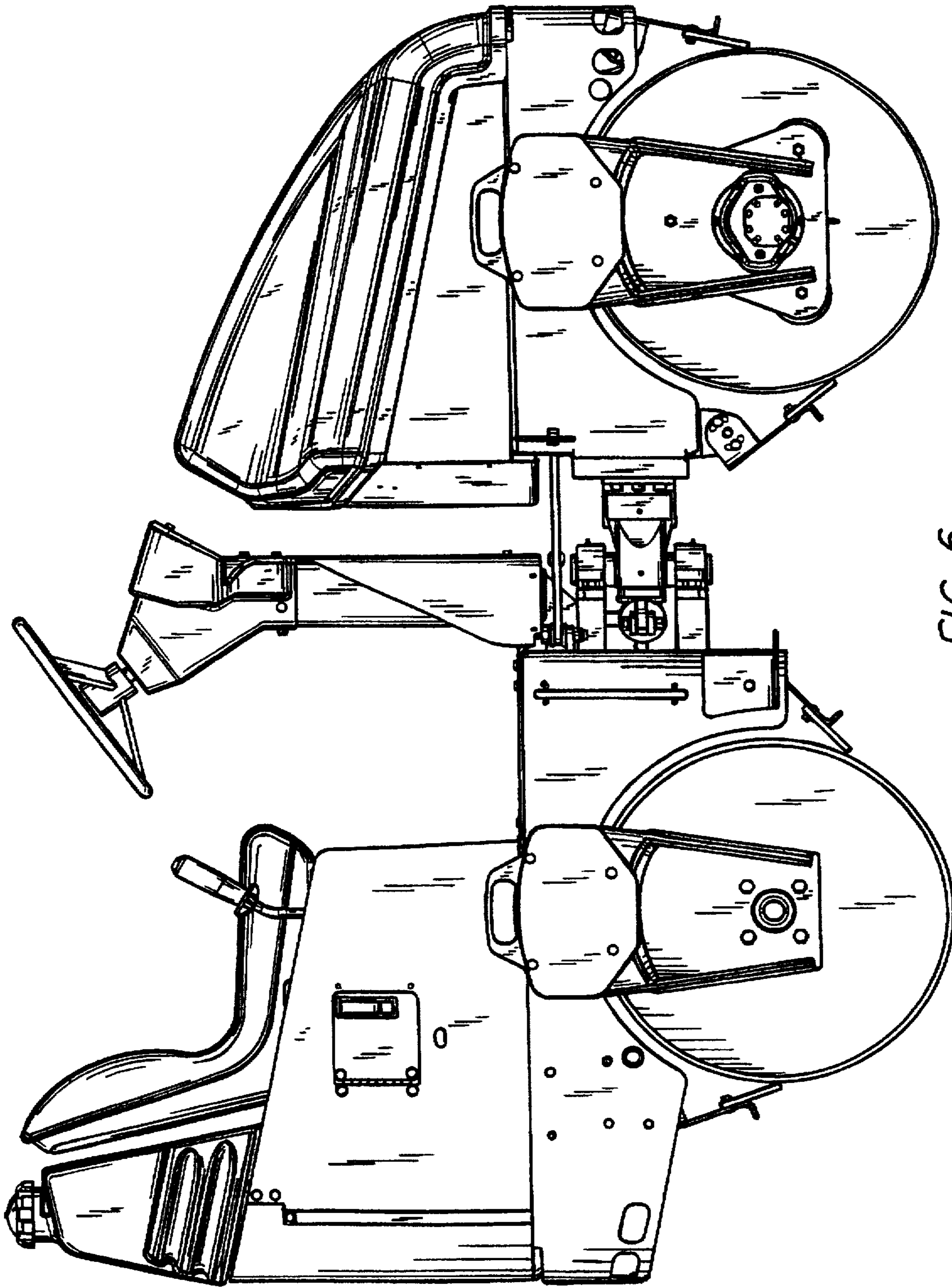

FIG. 6

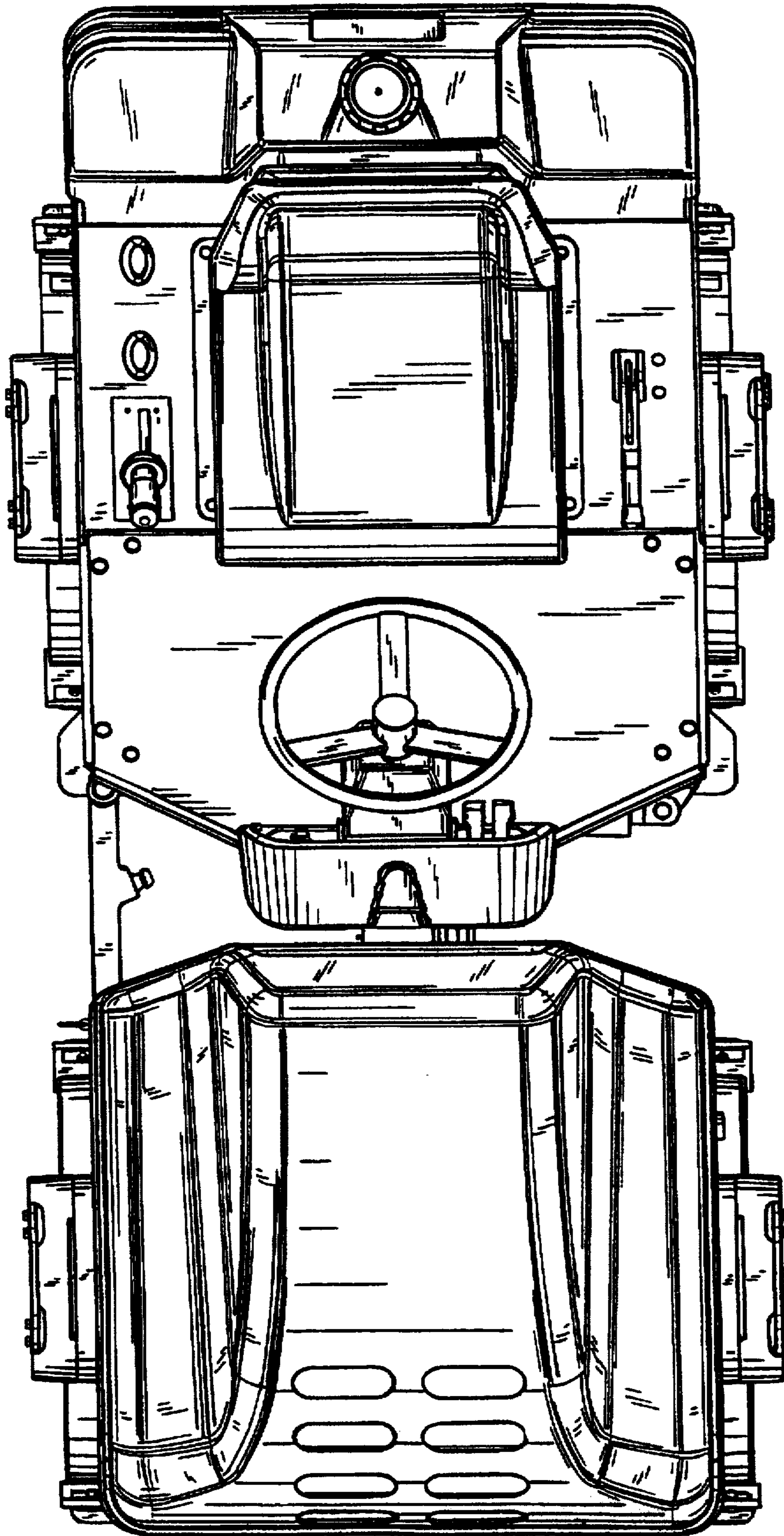

FIG. 7