

US00D396706S

United States Patent [19]

Rao

[11] Patent Number: **Des. 396,706**

[45] Date of Patent: ****Aug. 4, 1998**

[54] **COMBINED MAIN DRIVE AND ADAPTER ASSEMBLY**

[75] Inventor: **Mahesh Chandra Rao**, San Jose, Calif.

[73] Assignee: **Mitsubishi Chemical America, Inc.**, White Plains, N.Y.

[**] Term: **14 Years**

[21] Appl. No.: **73,888**

[22] Filed: **Jul. 18, 1997**

Related U.S. Application Data

[63] Continuation-in-part of Ser. No. 46,320, Nov. 13, 1995.

[51] LOC (6) Cl. **14-02**

[52] U.S. Cl. **D14/109; D14/107**

[58] Field of Search D14/100, 102, D14/107-109, 114; D13/162, 184, 199, 146, 147, 133; D6/432, 436, 445, 448; 360/97.01, 97.04, 99.12; 361/694, 696, 679-686; 439/620; 395/821

[56] References Cited

U.S. PATENT DOCUMENTS

D. 272,340	1/1984	Korzik	D14/107 X
D. 311,740	10/1990	Wagner	D14/107
D. 336,077	6/1993	Barry et al.	D14/106
D. 336,467	6/1993	Pooley et al.	D13/147 X
D. 363,064	10/1995	Rogov	D14/114

Primary Examiner—Freda Nunn

Attorney, Agent, or Firm—Oblon, Spivak, McClelland, Maier & Neustadt, P.C.

[57] CLAIM

The ornamental design for a combined main drive and adapter assembly, as shown and described.

DESCRIPTION

FIG. 1 is a top, front and right side perspective view of combined main drive and adapter assembly embodying my new design;

FIG. 2 is a front elevational view thereof;

FIG. 3 is a rear view thereof;

FIG. 4 is a left side view thereof;

FIG. 5 is a right side view thereof;

FIG. 6 is a top plan view thereof;

FIG. 7 is a bottom plan view thereof;

FIG. 8 is a left side view of the main drive portion of the combined main drive and adapter assembly shown separately for clarity of illustration only as taken along line 8-8 in FIG. 2;

FIG. 9 is a right side view of the adapter portion of the combined main drive and adapter assembly as taken along line 9-9 in FIG. 2;

FIG. 10 is a top plan view of the combined main drive and adapter assembly, showing a portion of the main drive when uncovered; and,

FIG. 11 is a top and front perspective view thereof.

The broken lines are shown in FIG. 8 for illustrative purposes only and form no part of the claimed design.

1 Claim, 5 Drawing Sheets

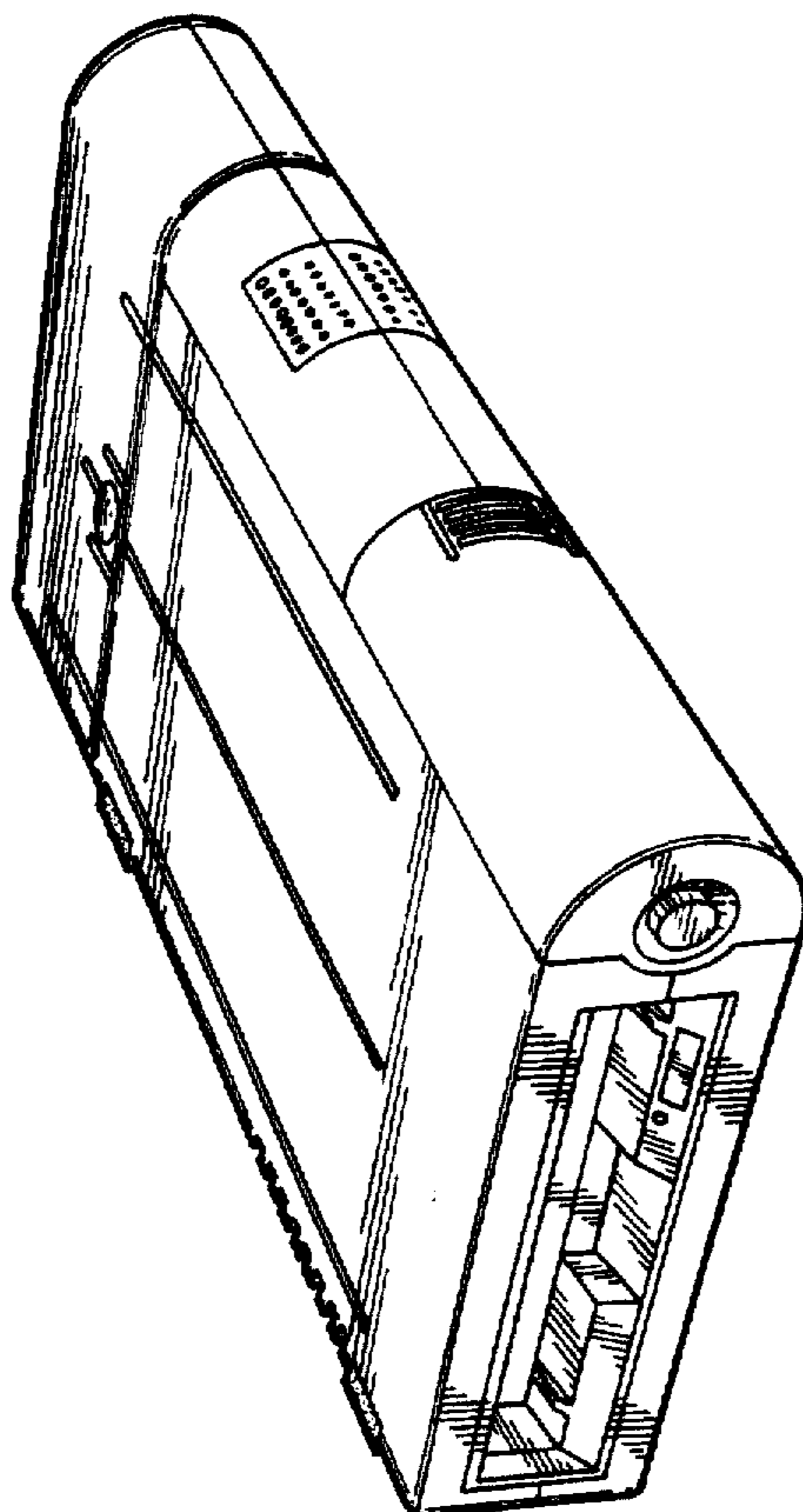

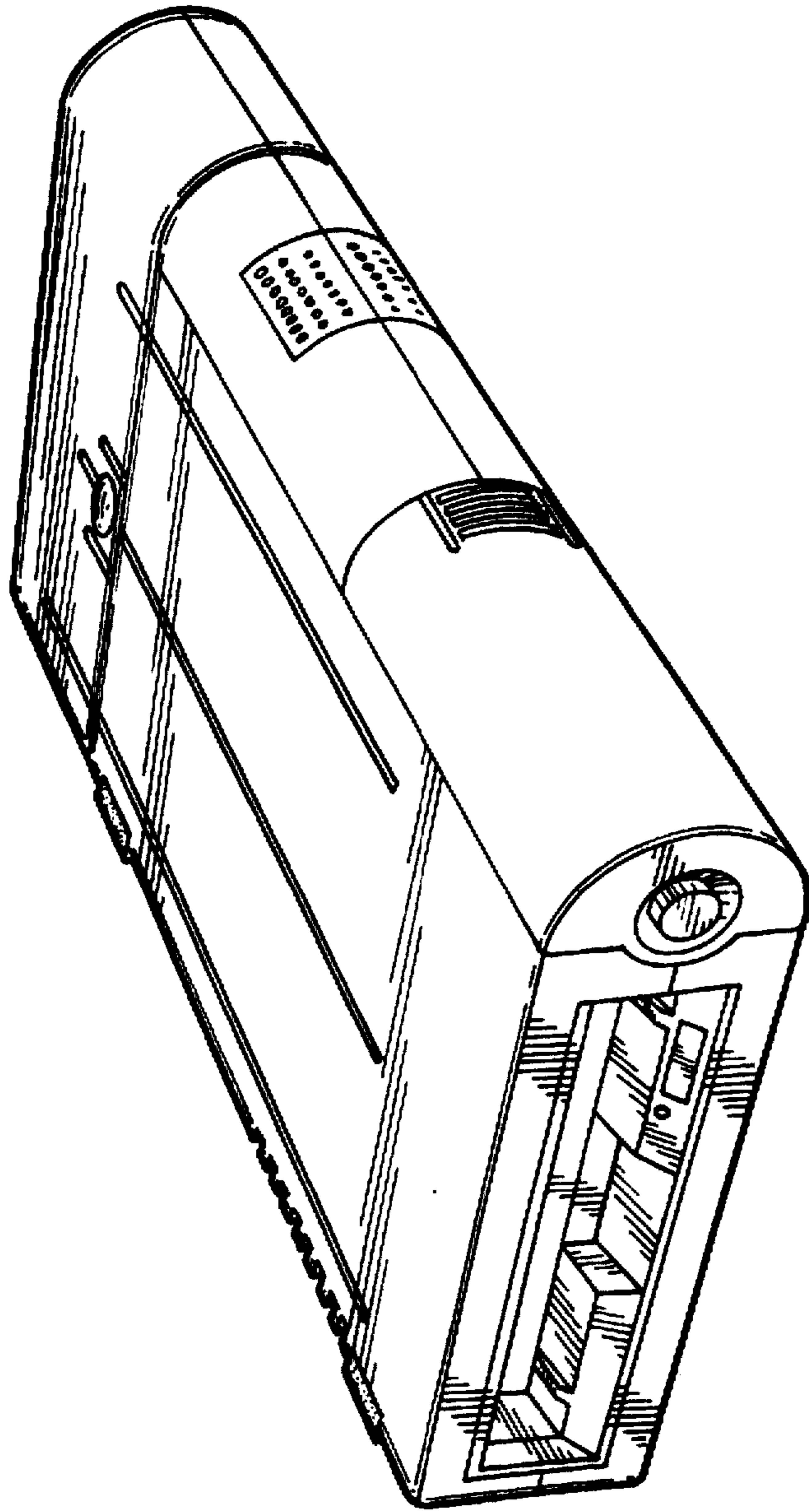
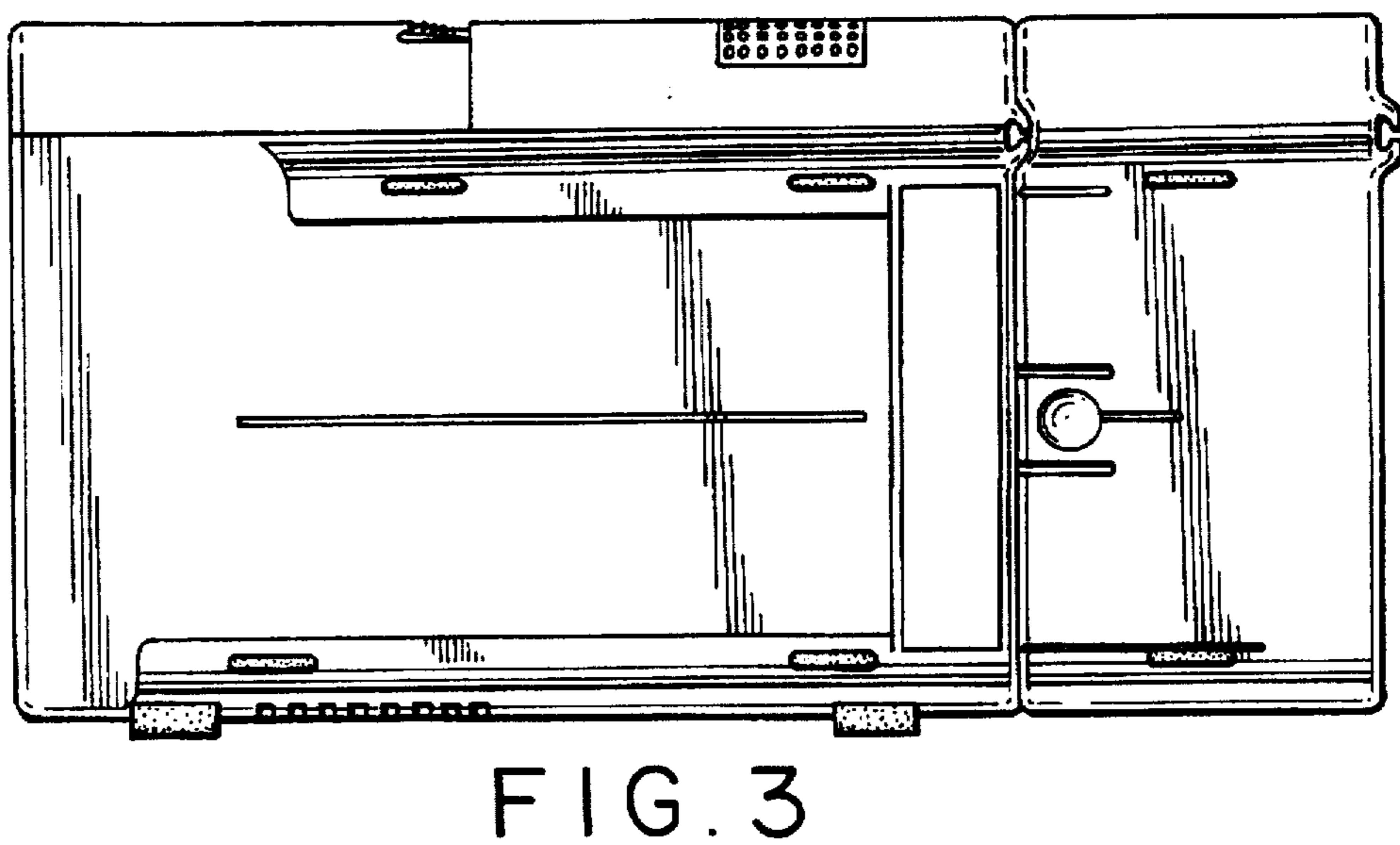
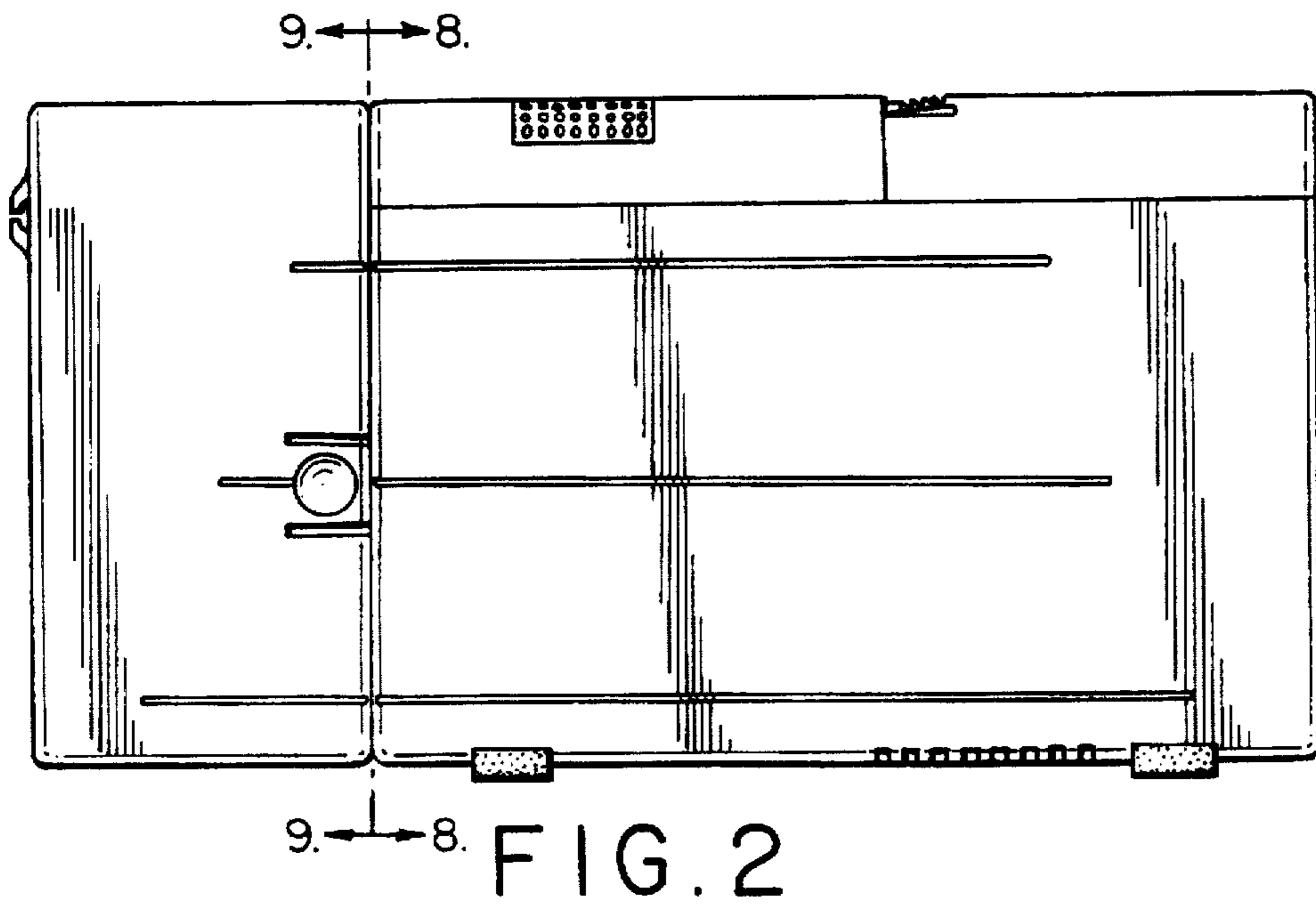

FIG. 1



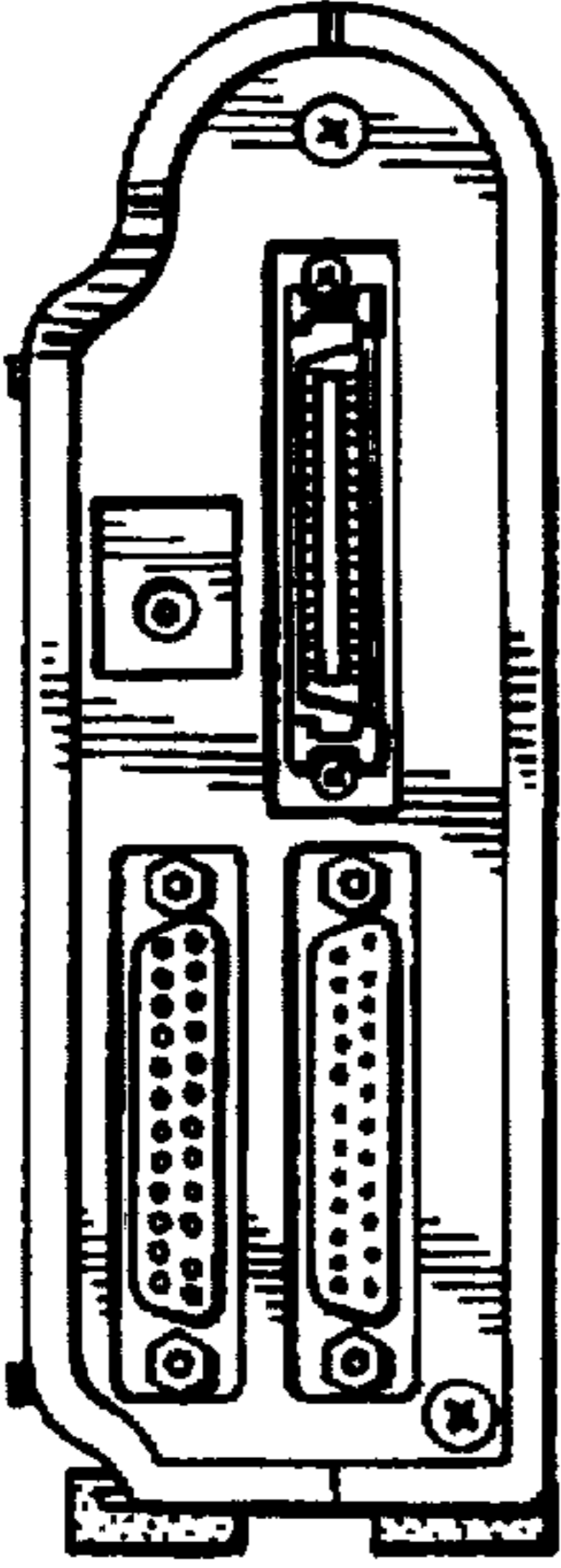

FIG. 4

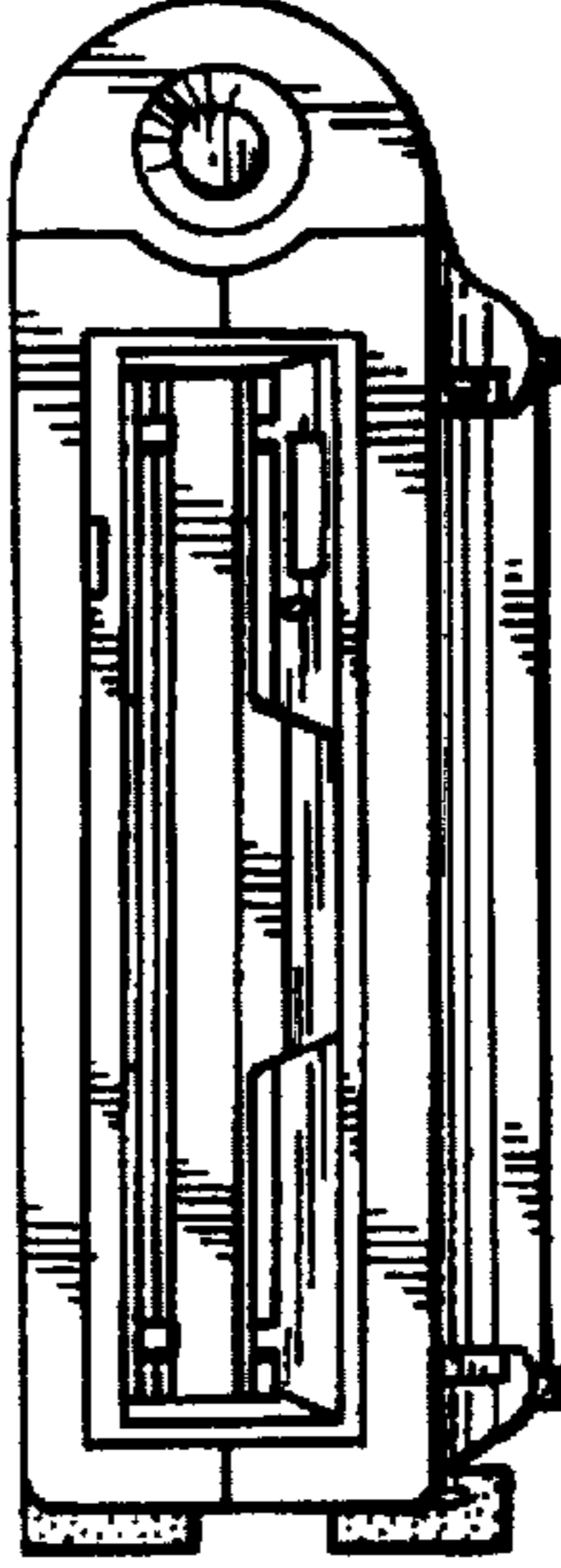

FIG. 5

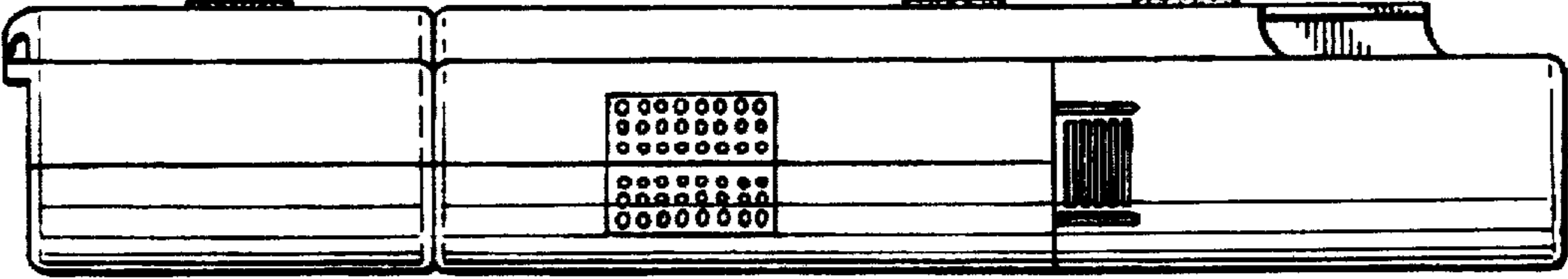

FIG. 6

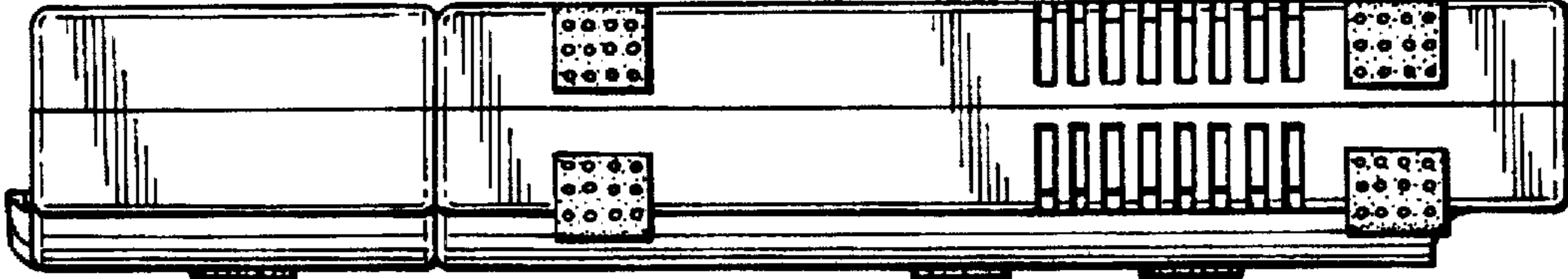

FIG. 7

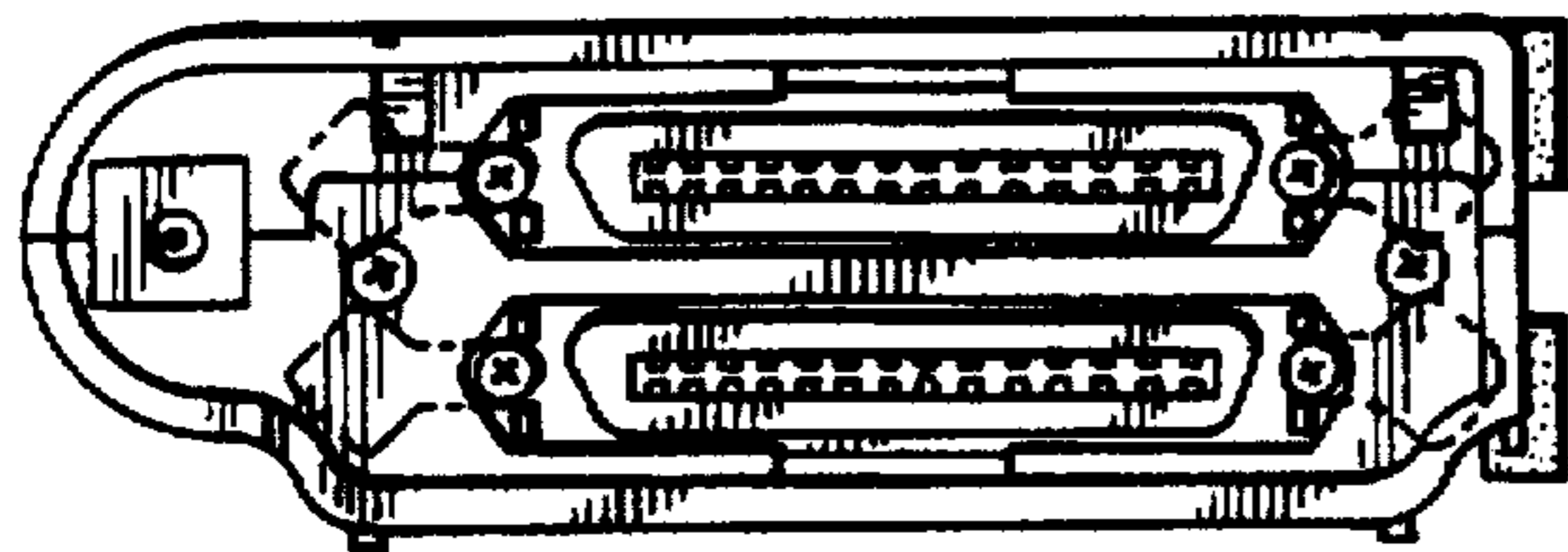

FIG. 8

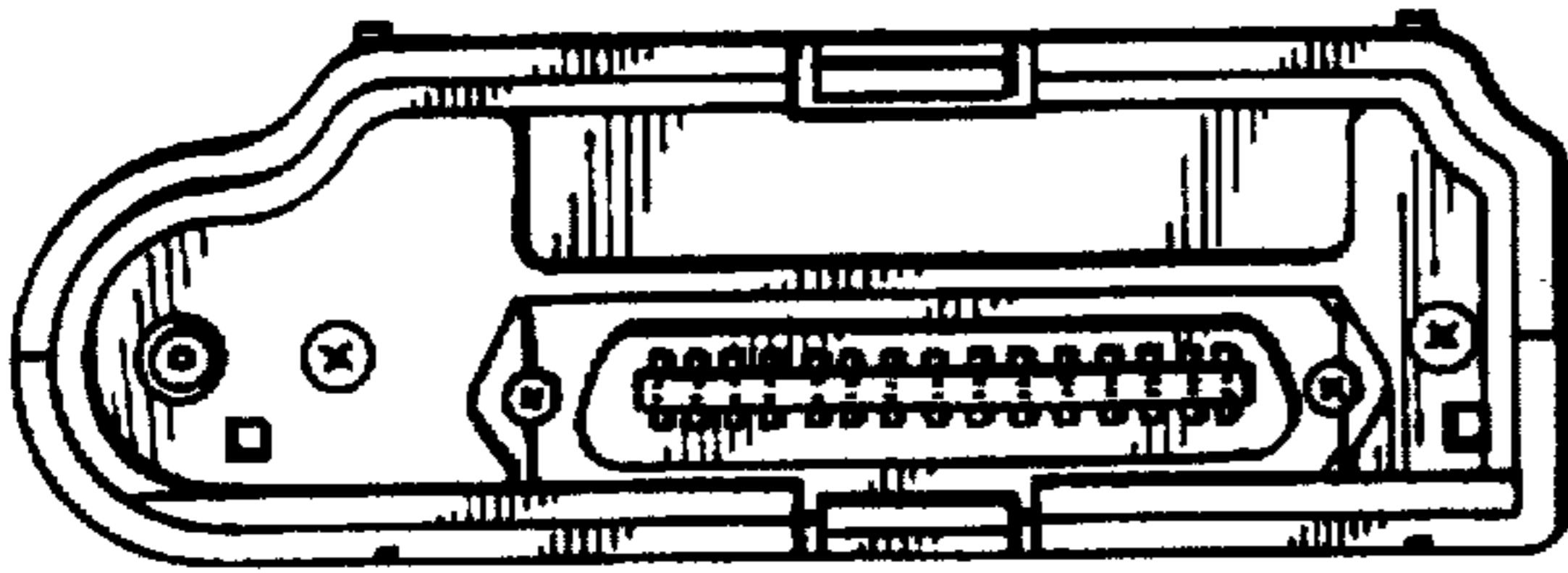

FIG. 9

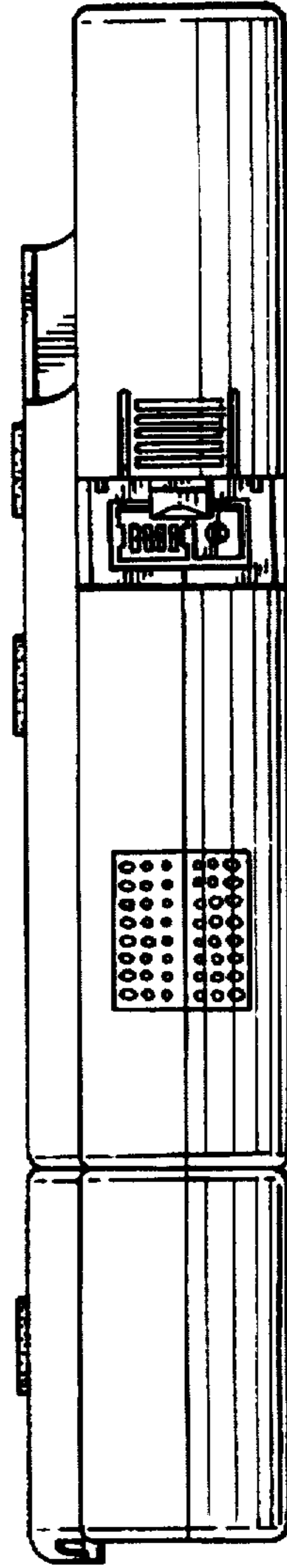

FIG. 10

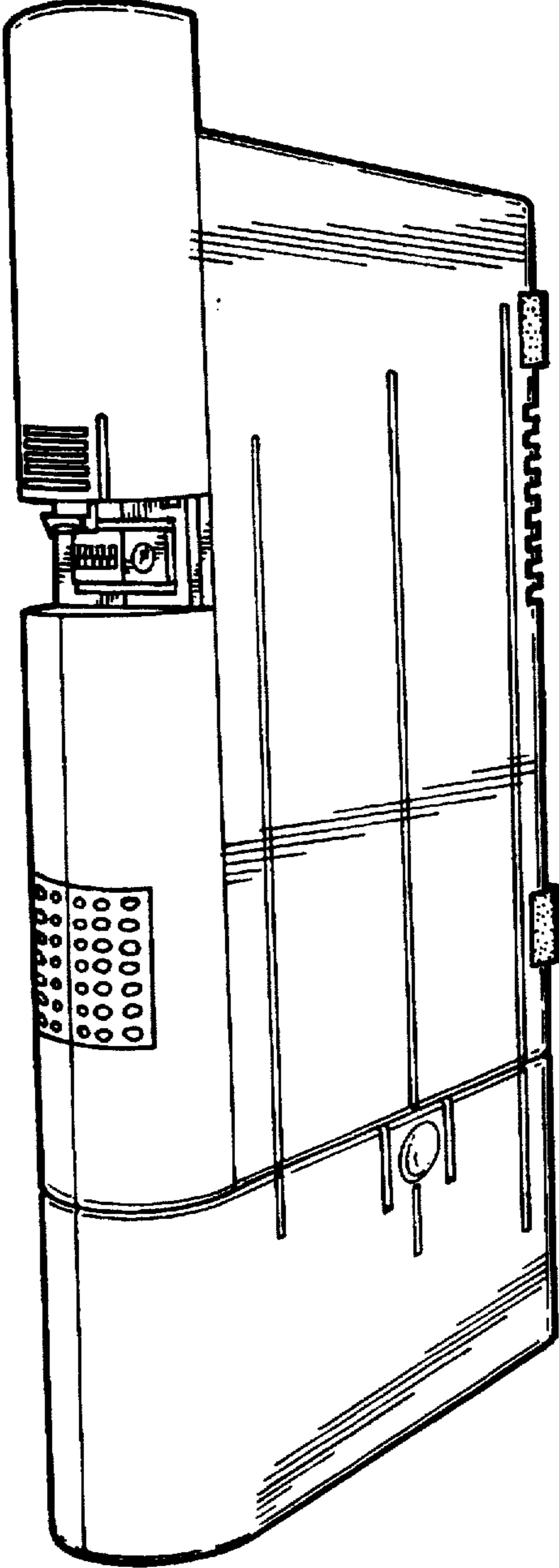

FIG.11