



US00D396687S

United States Patent [19]

Somers

[11] Patent Number: **Des. 396,687**

[45] Date of Patent: ****Aug. 4, 1998**

[54] **COMBINED FOUR PORT CHARGER WITH BATTERIES**

[75] Inventor: **Robert L. Somers**, Reisterstown, Md.

[73] Assignee: **Black & Decker Inc.**, Newark, Del.

[**] Term: **14 Years**

[21] Appl. No.: **72,843**

[22] Filed: **Jul. 1, 1997**

Related U.S. Application Data

[62] Division of Ser. No. 42,567, Aug. 11, 1995, Pat. No. Des. 389,799.

[51] LOC (6) Cl. **13-02**

[52] U.S. Cl. **D13/107**

[58] Field of Search **D13/107, 108; 320/2, 3, 4, 15**

[56] References Cited

U.S. PATENT DOCUMENTS

D. 211,850 8/1968 Shalvoy D13/108

D. 255,029 5/1980 Bromlie D13/108
D. 337,985 8/1993 Kindschuh D13/104
D. 349,883 8/1994 Gallagher et al. D13/108

Primary Examiner—Joel Sincavage
Attorney, Agent, or Firm—Bruce S. Shapiro; Dennis A. Dearing; John D. Del Ponti

[57] CLAIM

The ornamental design for a combined four port charger with batteries, as shown and described.

DESCRIPTION

FIG. 1 is a front perspective view of a combined port charger with batteries showing my new design with batteries; FIG. 2 is a front elevational view of FIG. 1; FIG. 3 is a rear elevational view of FIG. 1; FIG. 4 is a right side elevational view of FIG. 1; FIG. 5 is a left side elevational view of FIG. 1; FIG. 6 is a top plan view of FIG. 1; and, FIG. 7 is a bottom plan view of FIG. 1. The broken lines shown in FIGS. 3 through 7 are included for the purpose of illustrating environmental structure only and form no part of the claimed design.

1 Claim, 4 Drawing Sheets

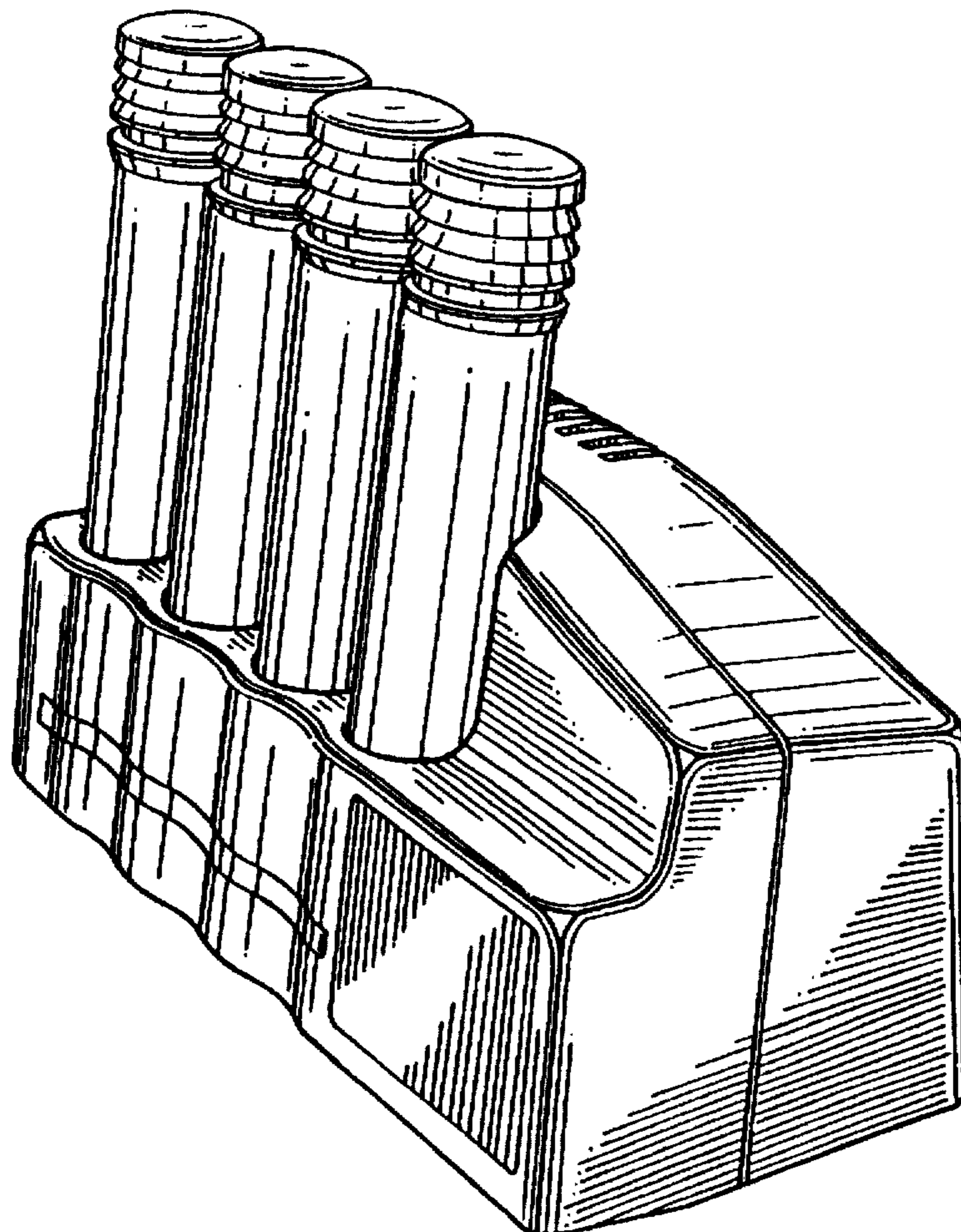

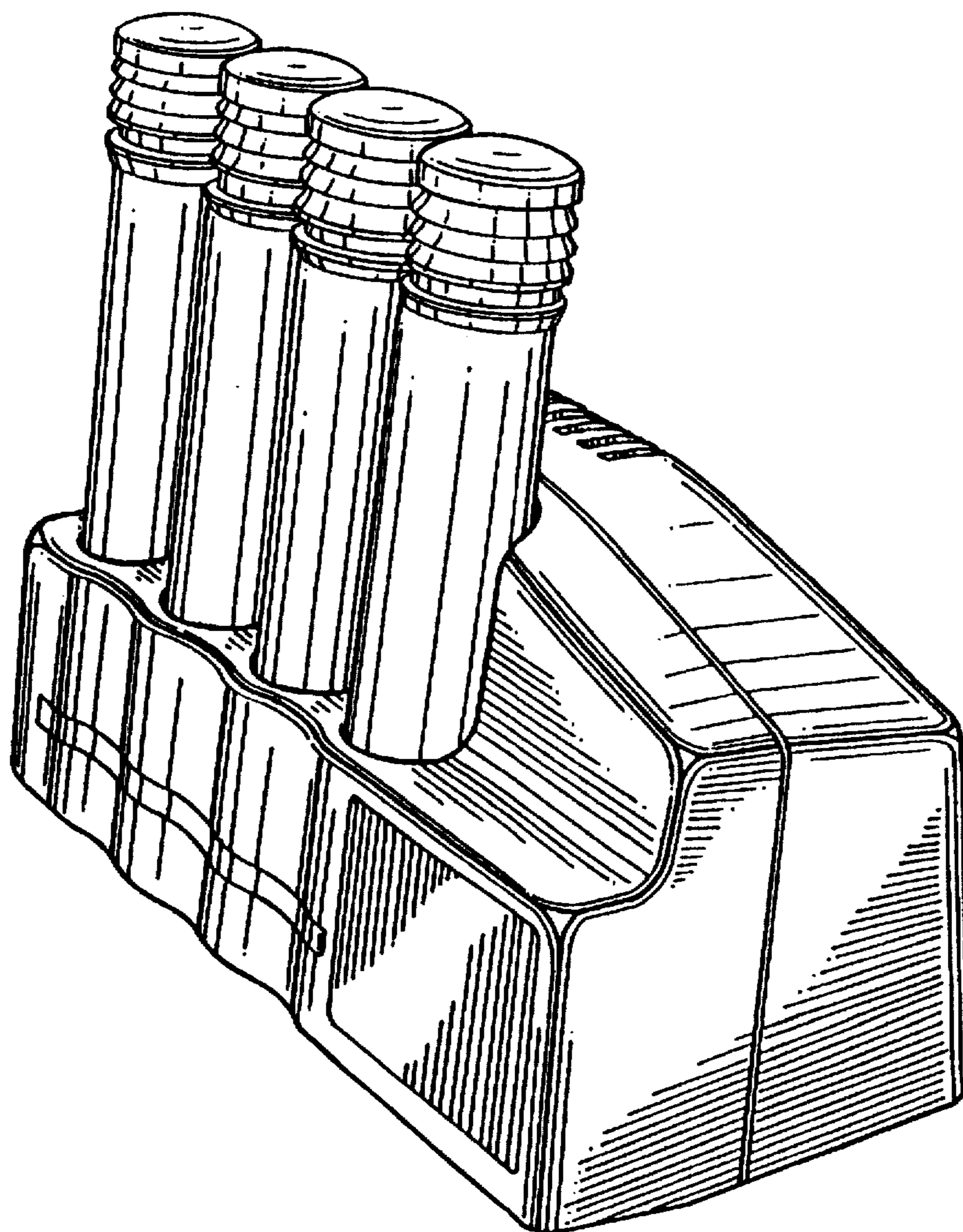

FIG. 1

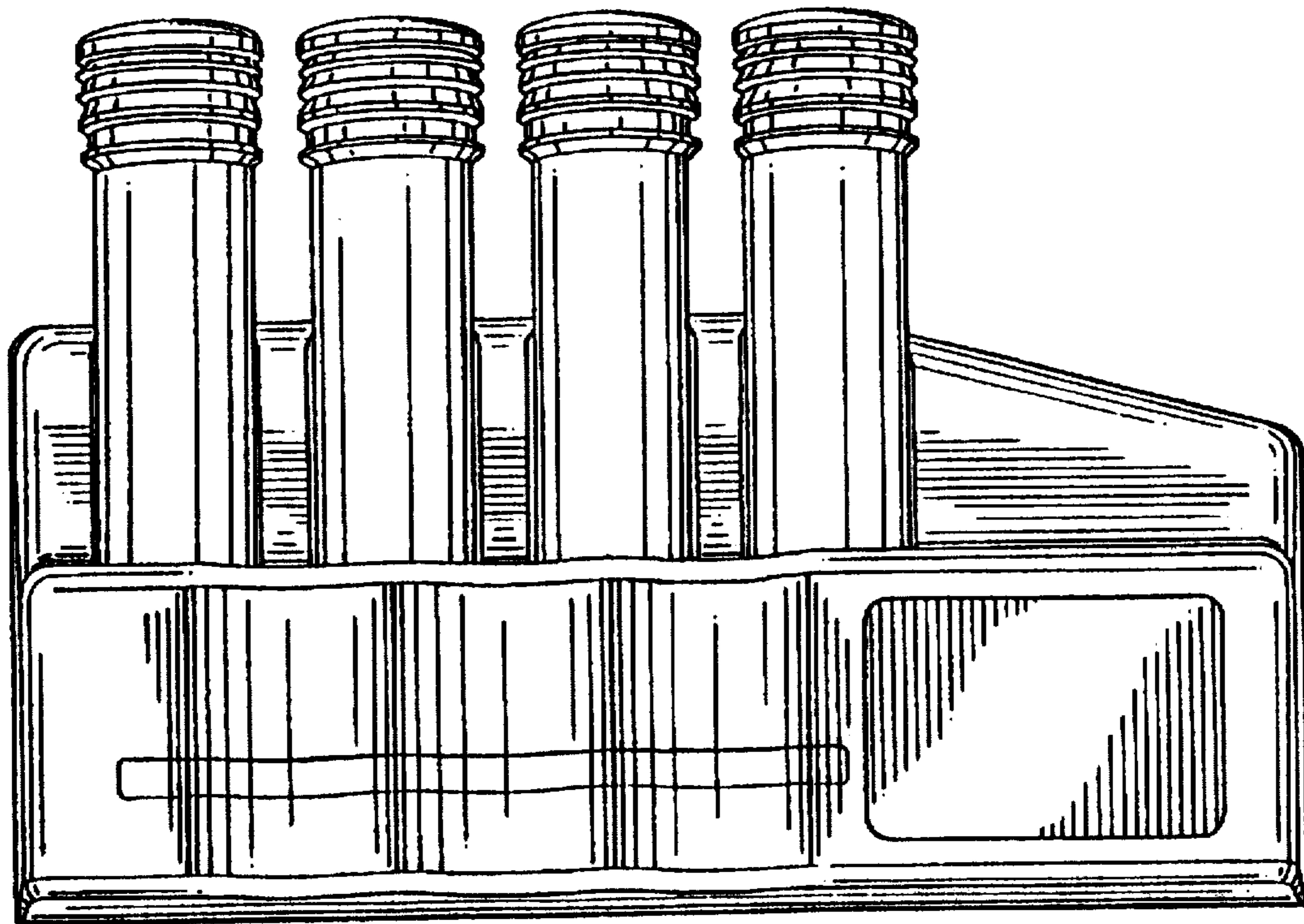

FIG. 2

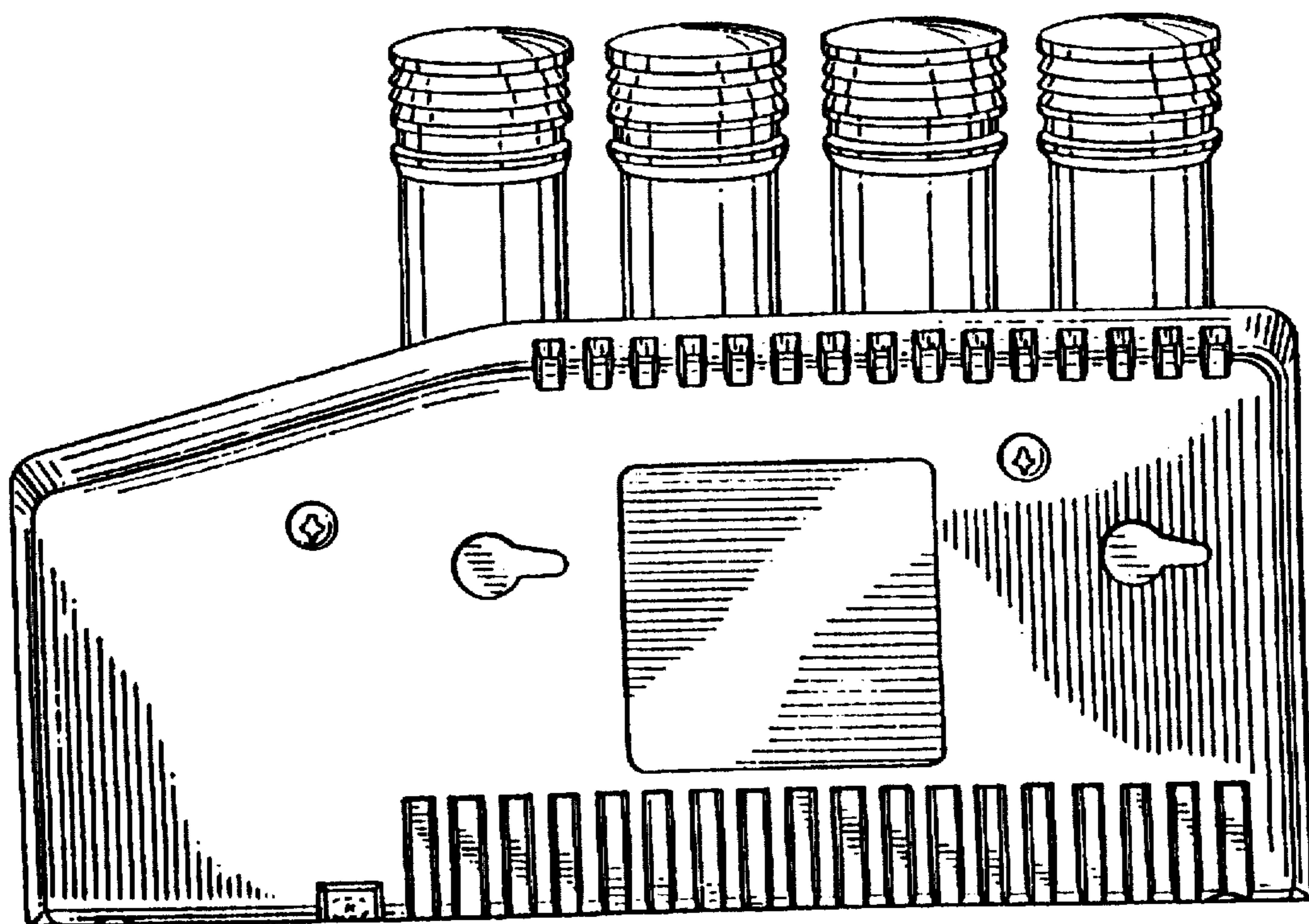

FIG. 3

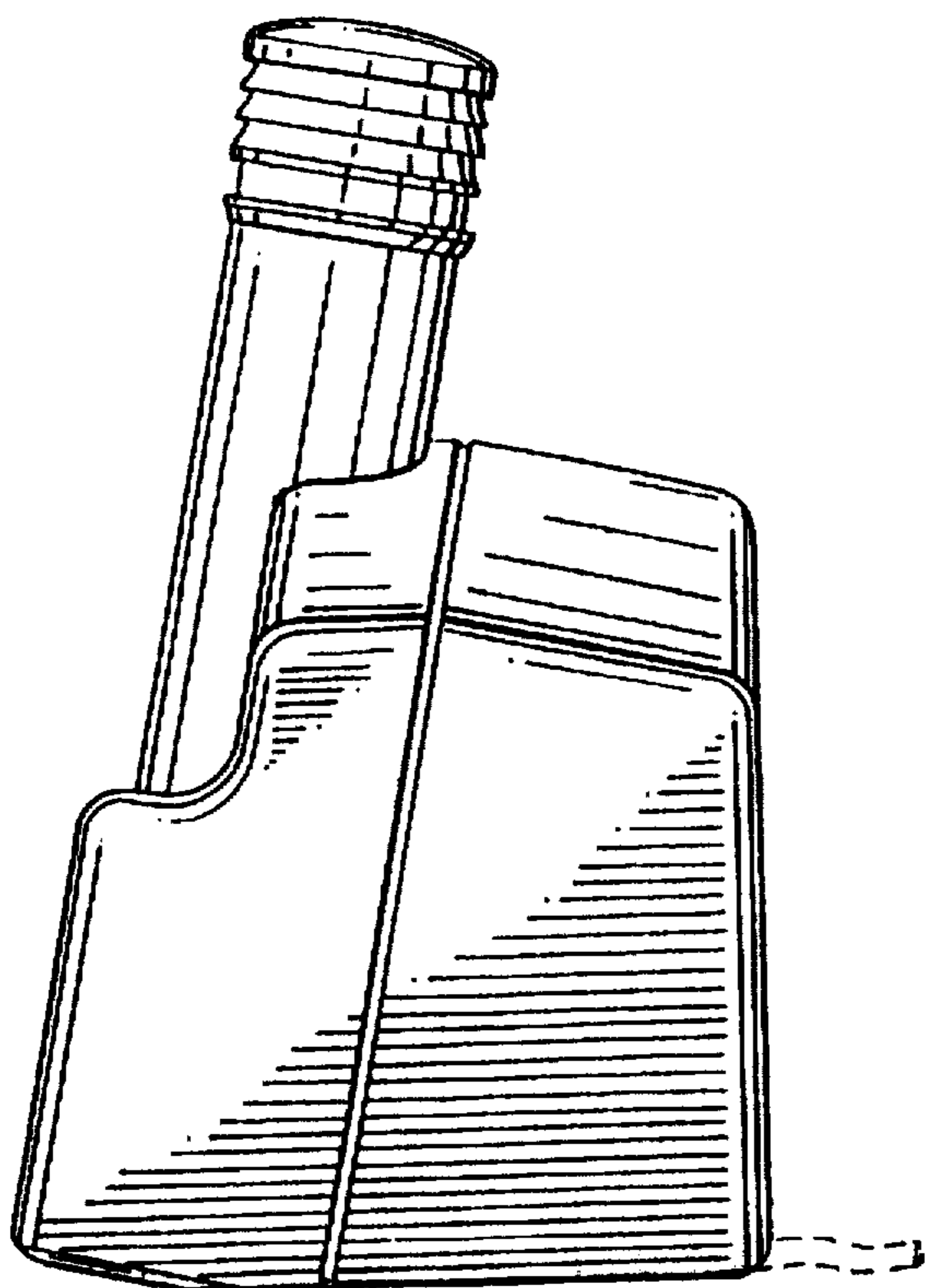

FIG. 4

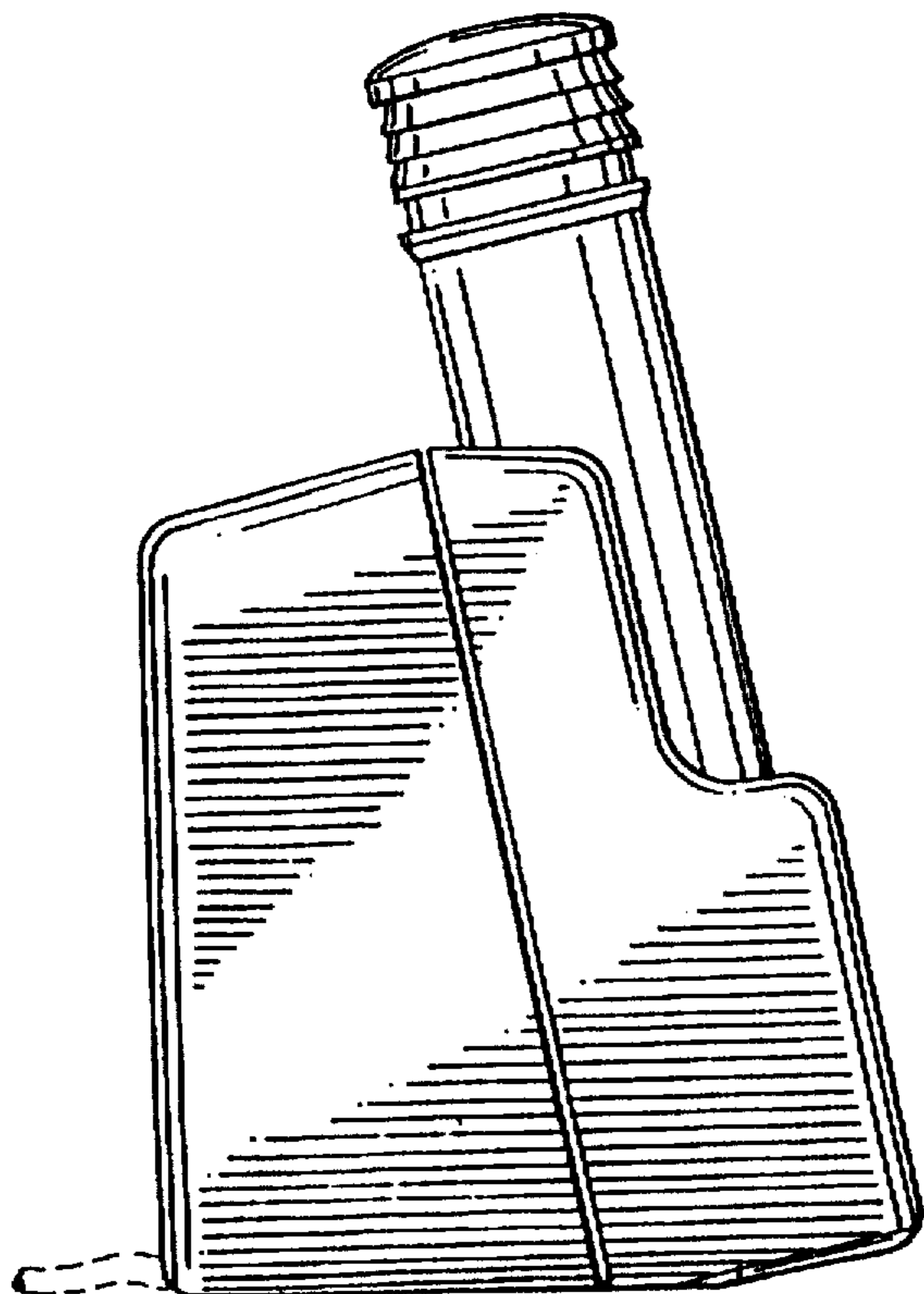

FIG. 5

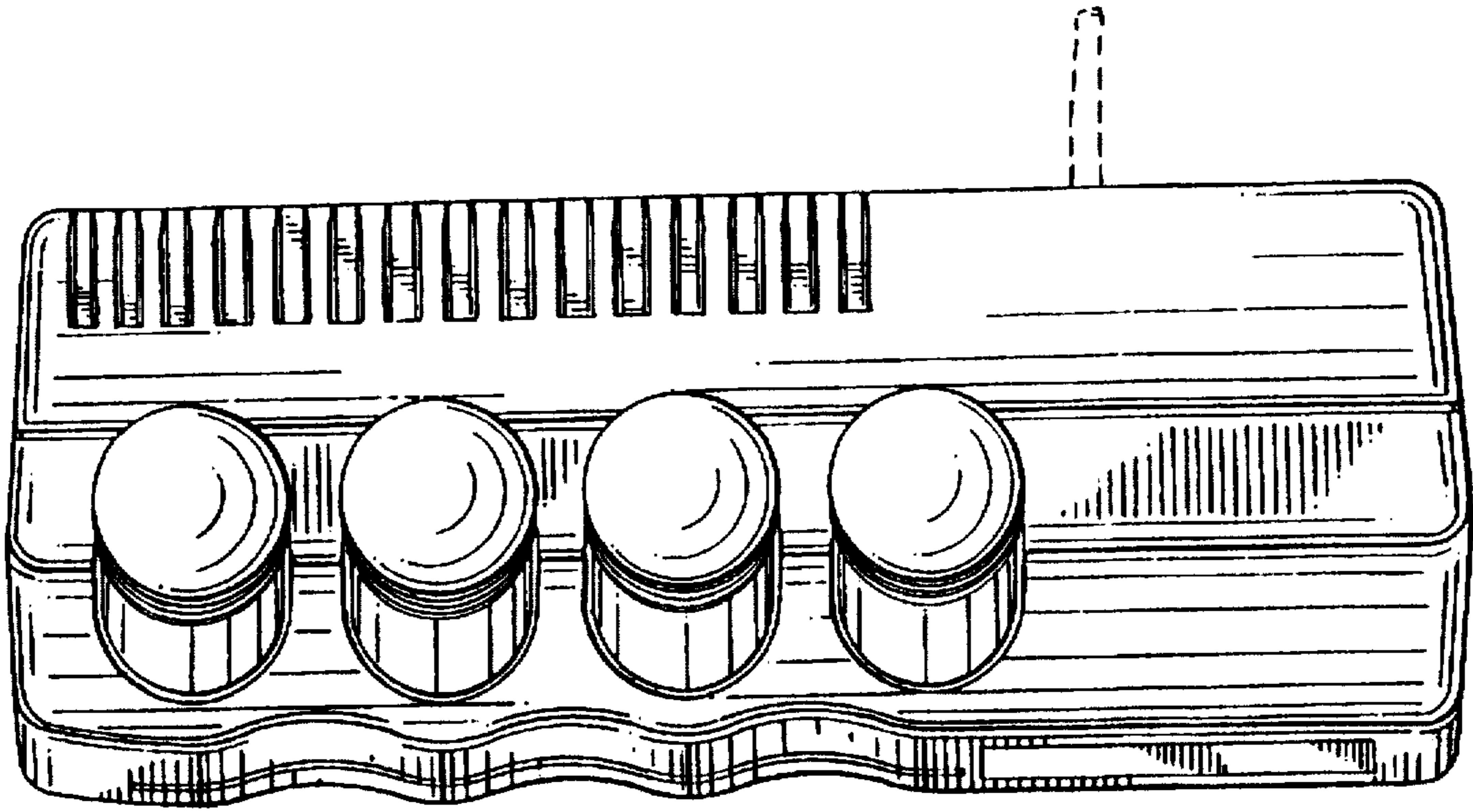

FIG. 6

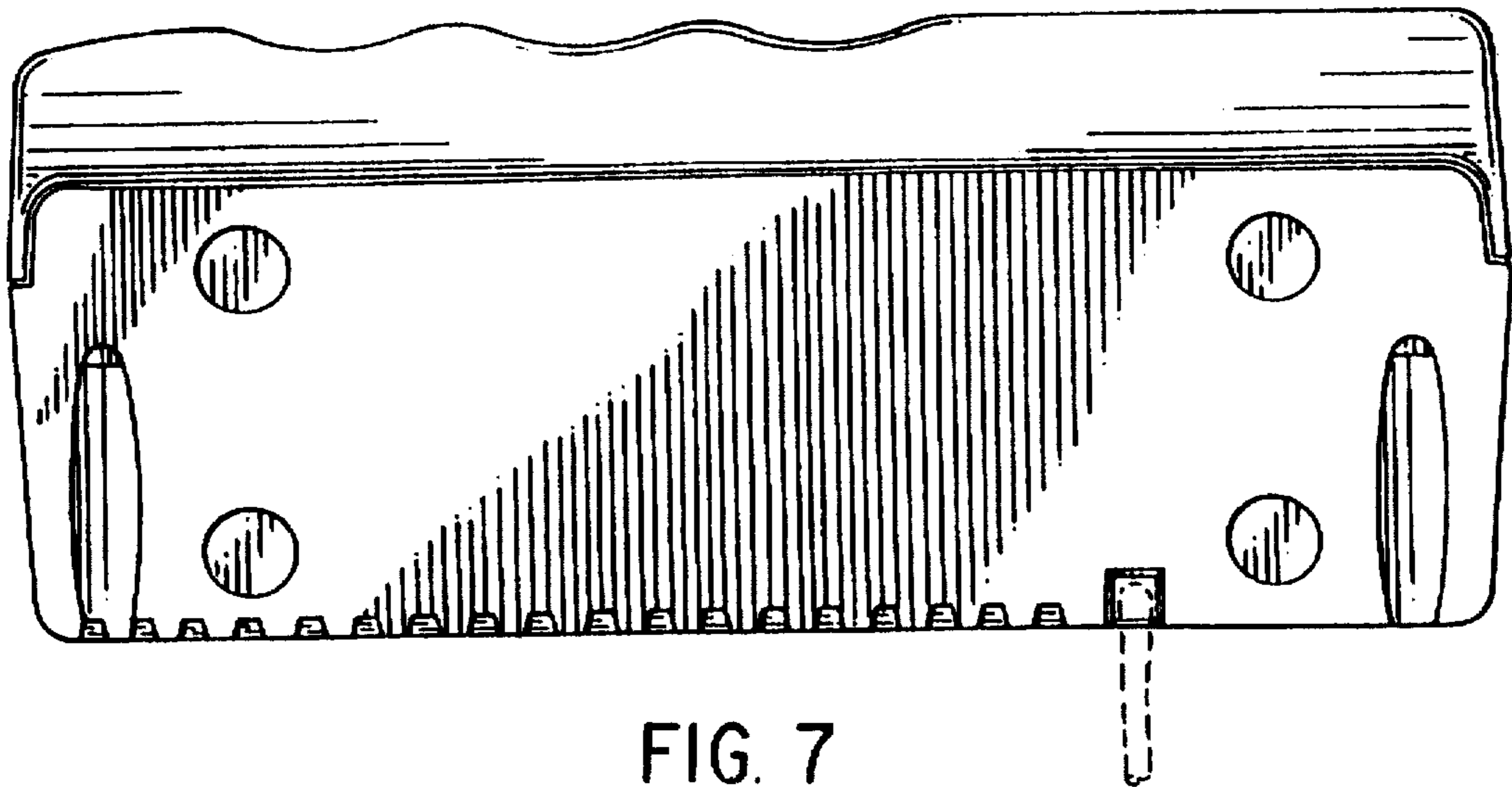

FIG. 7