



US00D396684S

United States Patent [19] Frigard

[11] Patent Number: **Des. 396,684**
[45] Date of Patent: ****Aug. 4, 1998**

[54] **WATERCRAFT**
[75] Inventor: **Charles Raymond Frigard, Mound, Minn.**
[73] Assignee: **NorthStar Marine, Inc., Mound, Minn.**
[**] Term: **14 Years**
[21] Appl. No.: **67,919**
[22] Filed: **Apr. 7, 1997**
[51] LOC (6) Cl. **12-06**
[52] U.S. Cl. **D12/304; D12/318**
[58] Field of Search **D12/300-318; 114/39.1, 61, 141, 132, 39.2, 43, 160**

5,377,607 1/1995 Ross .
5,392,726 2/1995 Benze .
5,617,805 4/1997 Frigard 114/61

FOREIGN PATENT DOCUMENTS

2662658 6/1991 France .

Primary Examiner—Kay H. Chin
Attorney, Agent, or Firm—Dorsey & Whitney LLP

[57] CLAIM

The ornamental design for a watercraft, as shown and described.

DESCRIPTION

FIG. 1 is a right side perspective view of a watercraft showing my new design;
FIG. 2 is a right side elevational view thereof;
FIG. 3 is a left side elevational view thereof;
FIG. 4 is a front elevational view thereof;
FIG. 5 is a rear elevational view thereof;
FIG. 6 is a top plan view thereof; and,
FIG. 7 is a bottom plan view thereof.
The broken line showing of environmental structure in FIG. 1 in the drawing is for illustrative purposes only and forms no part of the claimed design.

[56] References Cited U.S. PATENT DOCUMENTS

D. 289,392 4/1987 Gary et al. .
D. 324,021 2/1992 Walker .
D. 371,104 6/1996 Frigard .
3,802,366 4/1974 Mankawich .
4,730,570 3/1988 Harris .
4,836,120 6/1989 Murphy .
5,189,974 3/1993 Masters .
5,235,925 8/1993 Farrier .

1 Claim, 3 Drawing Sheets

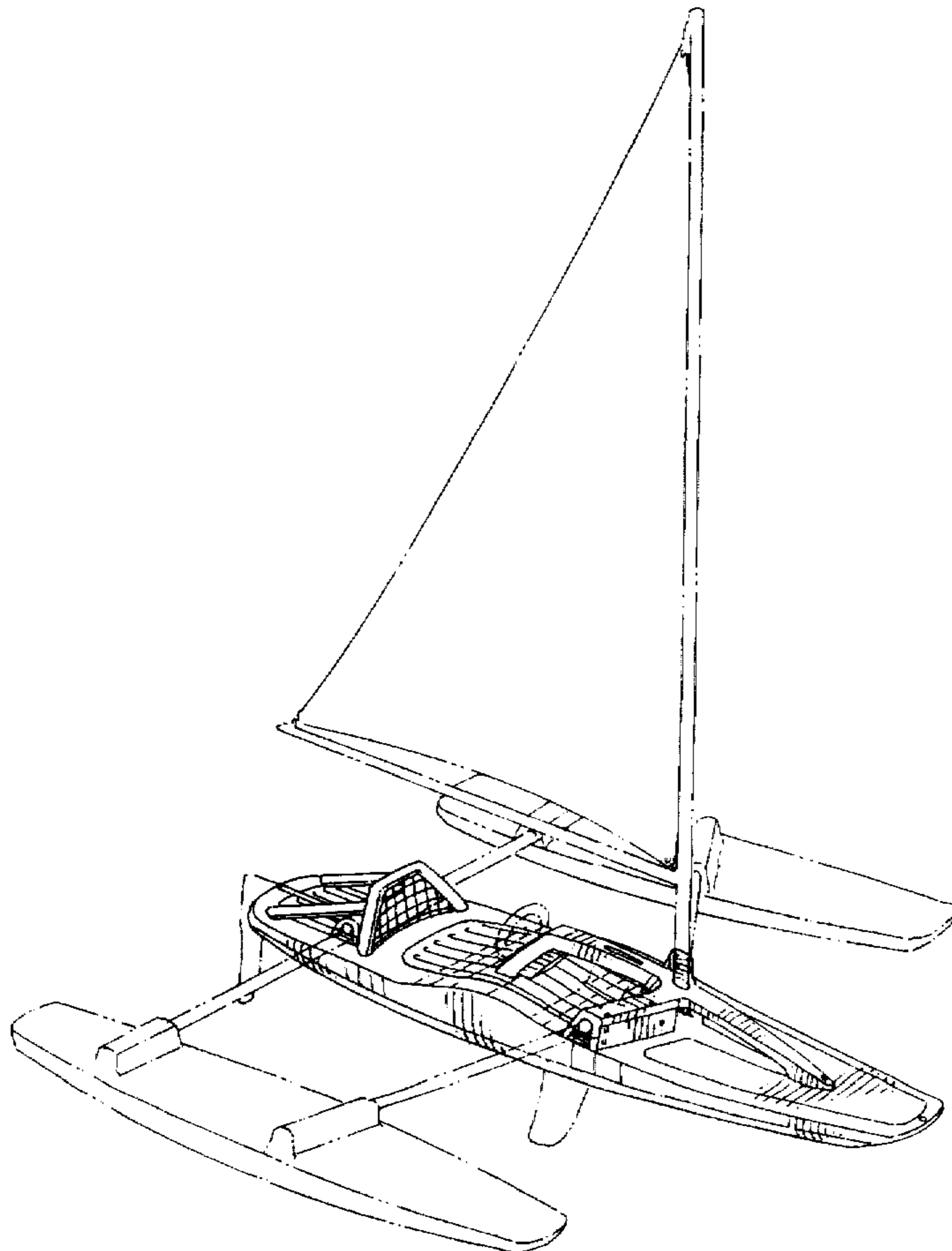

Fig. 1

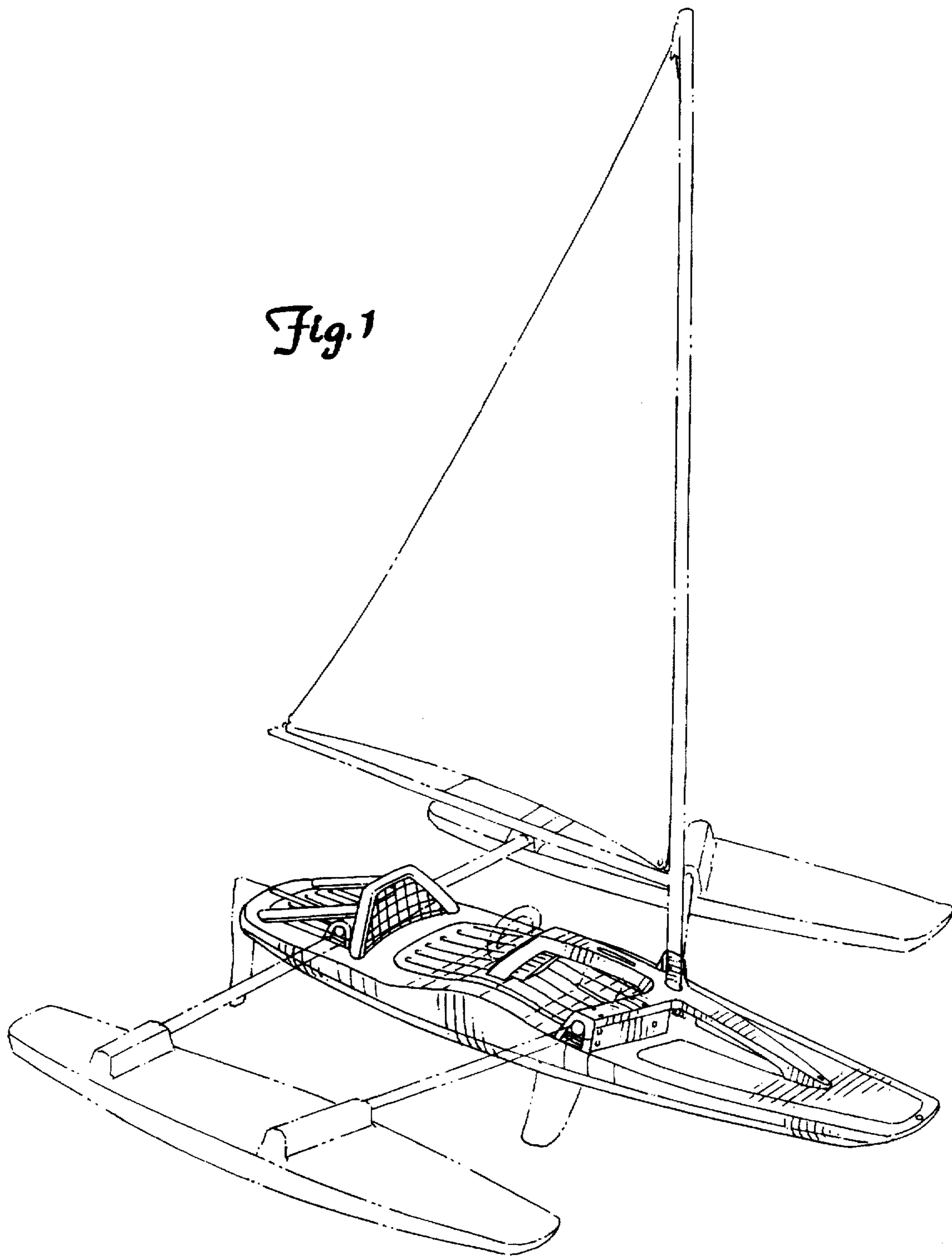

Fig. 2

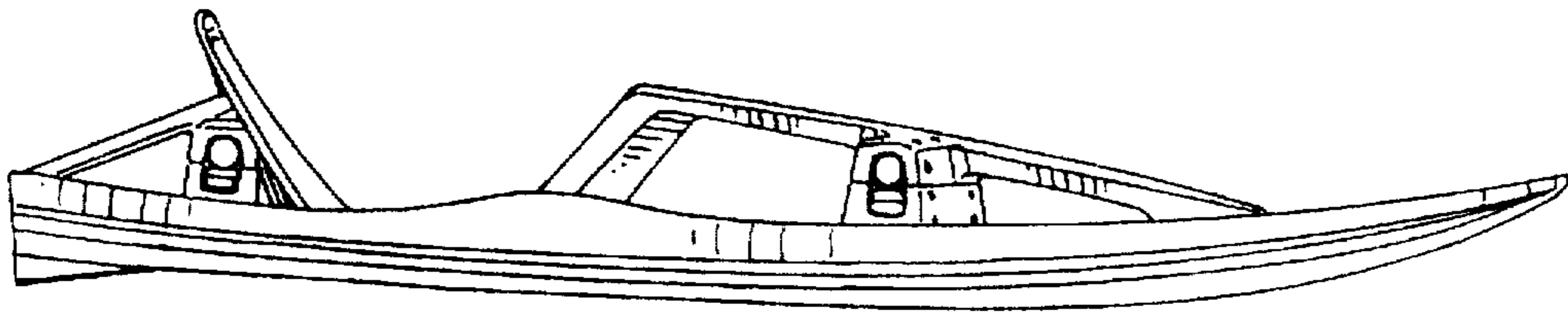

Fig. 3

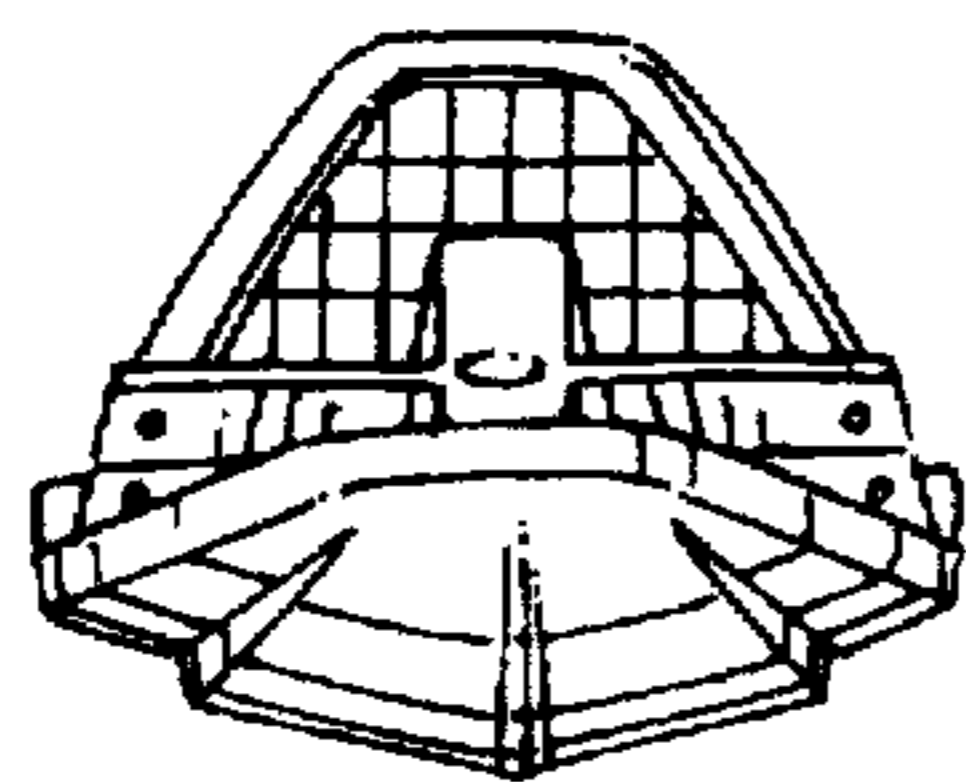
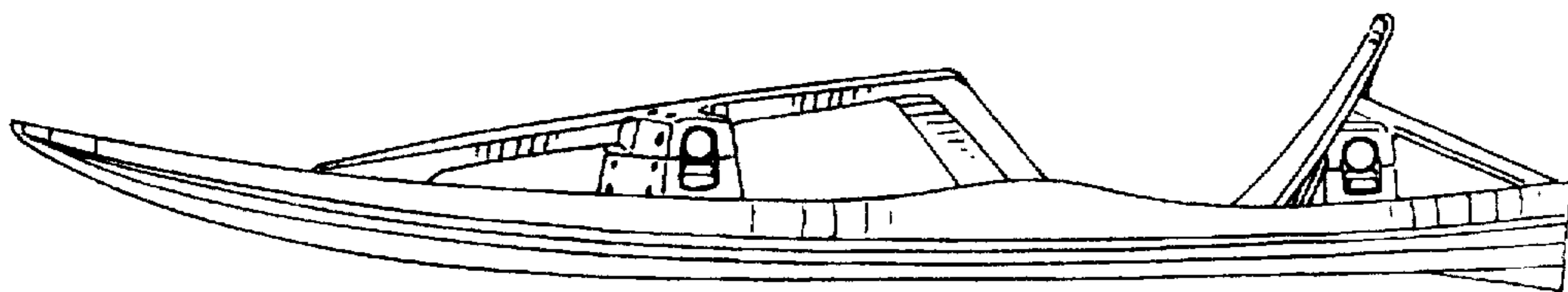
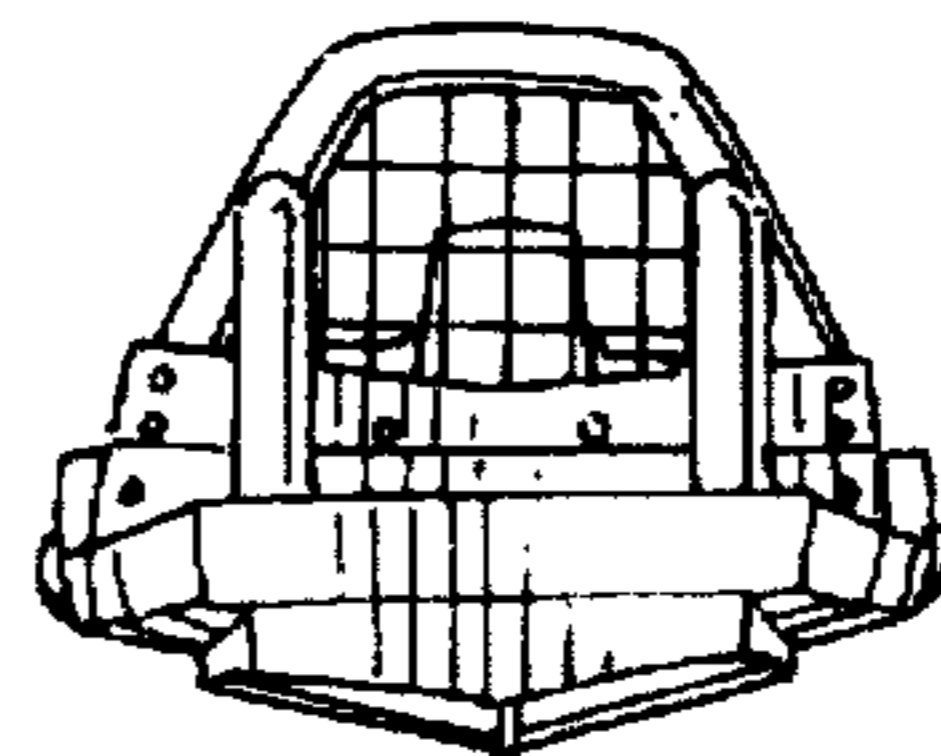

Fig. 4

Fig. 5



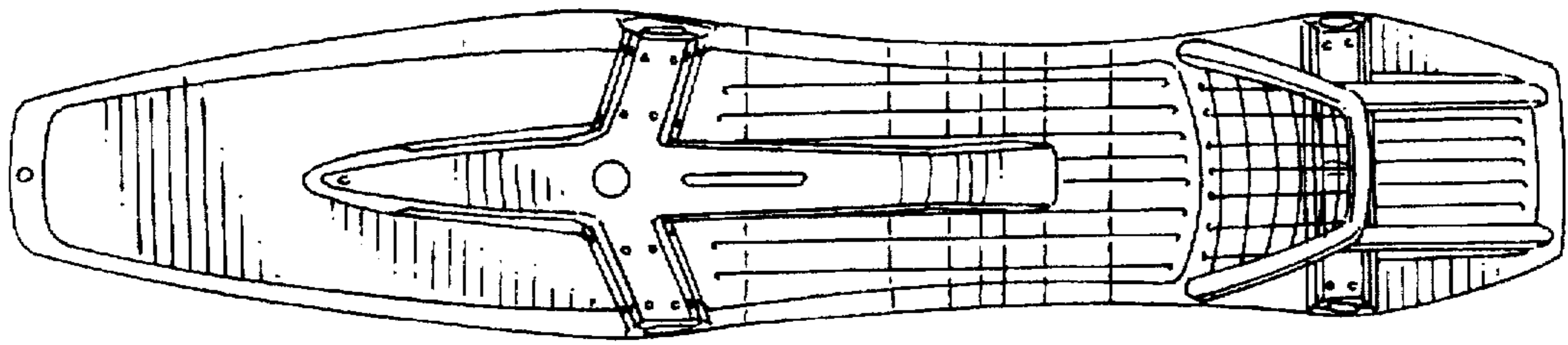

Fig. 6

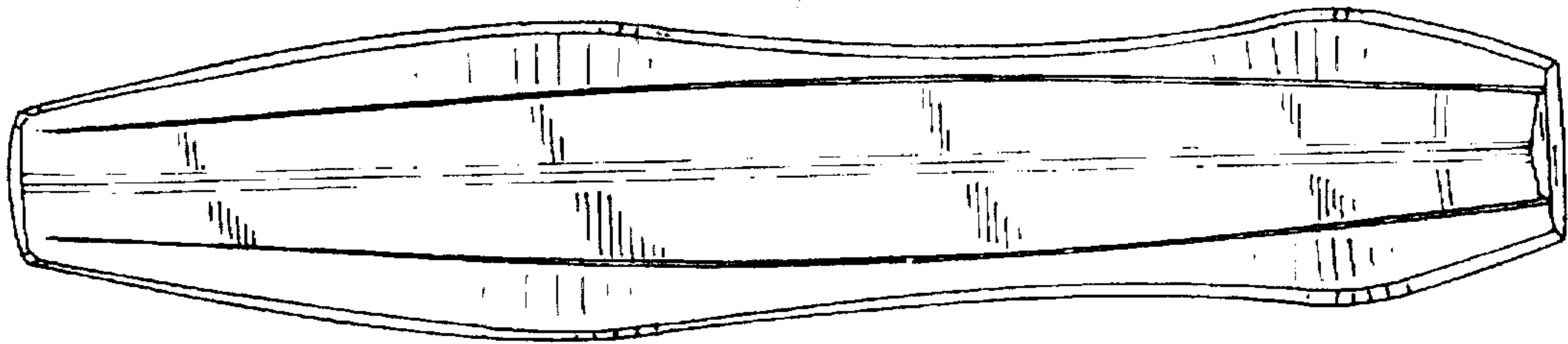

Fig. 7