



US00D396672S

**United States Patent** [19]  
**Stotsky**

[11] **Patent Number: Des. 396,672**  
[45] **Date of Patent: \*\*\*Aug. 4, 1998**

[54] **OVAL TOP-TUBE AND ONE-PIECE SEAT STAY COMBINATION**

D. 370,647 6/1996 Levin et al. .... D12/117  
5,452,911 9/1995 Klein et al. .... 280/288  
5,476,278 12/1995 Levin et al. .... 280/288

[76] **Inventor: Michael Stotsky, 1440 W. North Shore Apt. 1W, Chicago, Ill. 60626**

*Primary Examiner*—Melody N. Brown  
*Attorney, Agent, or Firm*—Emrich & Dithmar

[\*] **Notice:** The portion of the term of this patent subsequent to Sep. 9, 2011, has been disclaimed.

[57] **CLAIM**

The ornamental design for an oval top-tube and one-piece seat stay combination, as shown and described.

[\*\*] **Term: 14 Years**

**DESCRIPTION**

[21] **Appl. No.: 50,289**

FIG. 1 is a right side elevational view of an oval top-tube and one-piece seat stay combination, it being understood that the broken lines are for illustrative purposes only, and form no part of the claimed design;

[22] **Filed: Feb. 13, 1996**

FIG. 2 is a perspective view thereof;

[51] **LOC (6) Cl. .... 12-11**

[52] **U.S. Cl. .... D12/117**

FIG. 3 is a right side elevational view thereof;

[58] **Field of Search .... D12/117, 111;**

280/281.1, 288.1-288.3, 288

FIG. 4 is a top plan view thereof;

FIG. 5 is a bottom plan view thereof;

FIG. 6 is a front elevational view thereof; and,

FIG. 7 is a rear elevational view thereof.

[56] **References Cited**

**U.S. PATENT DOCUMENTS**

D. 343,811 2/1994 Weidberg .... D12/119

**1 Claim, 2 Drawing Sheets**

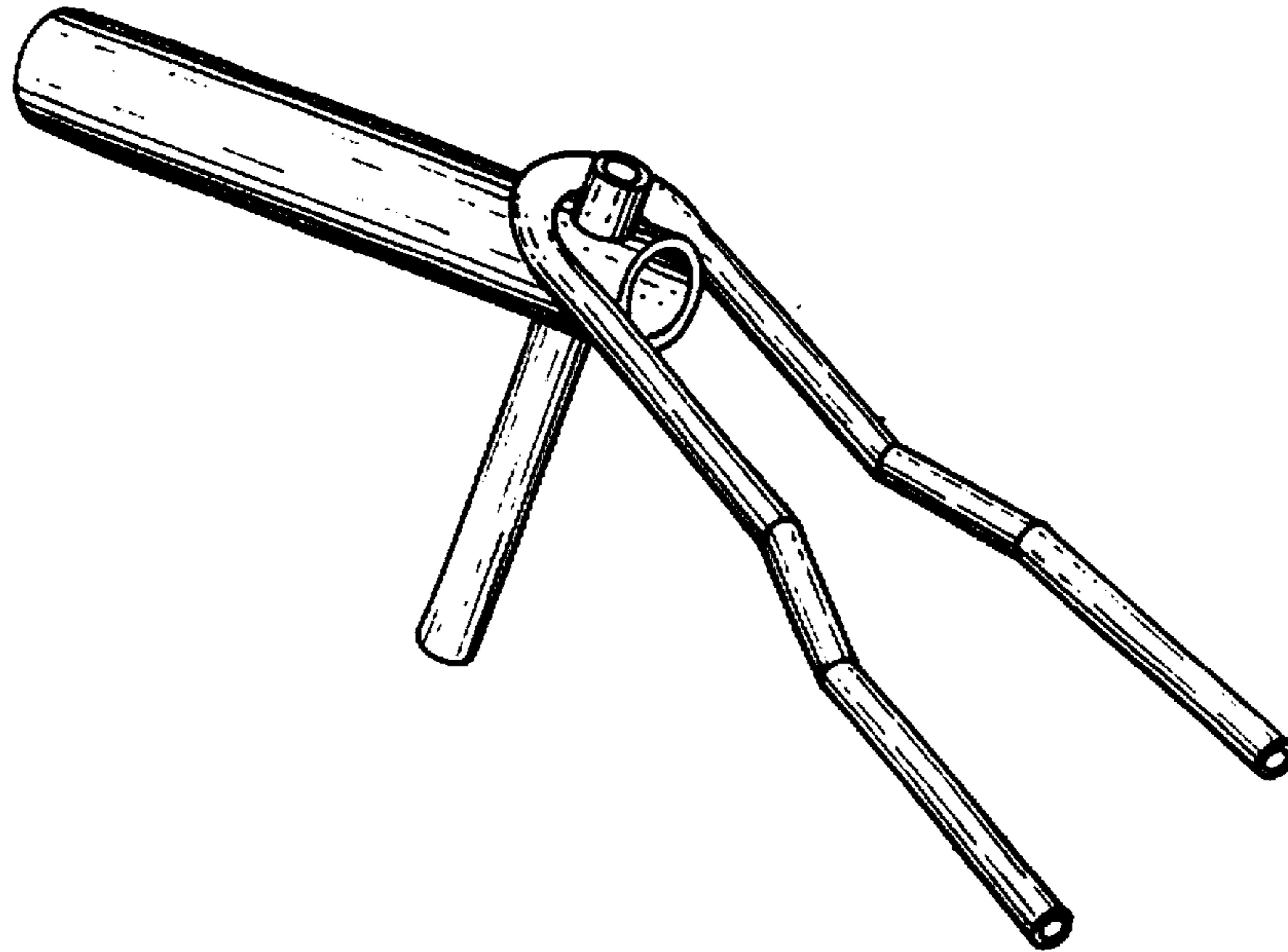

FIG. 1

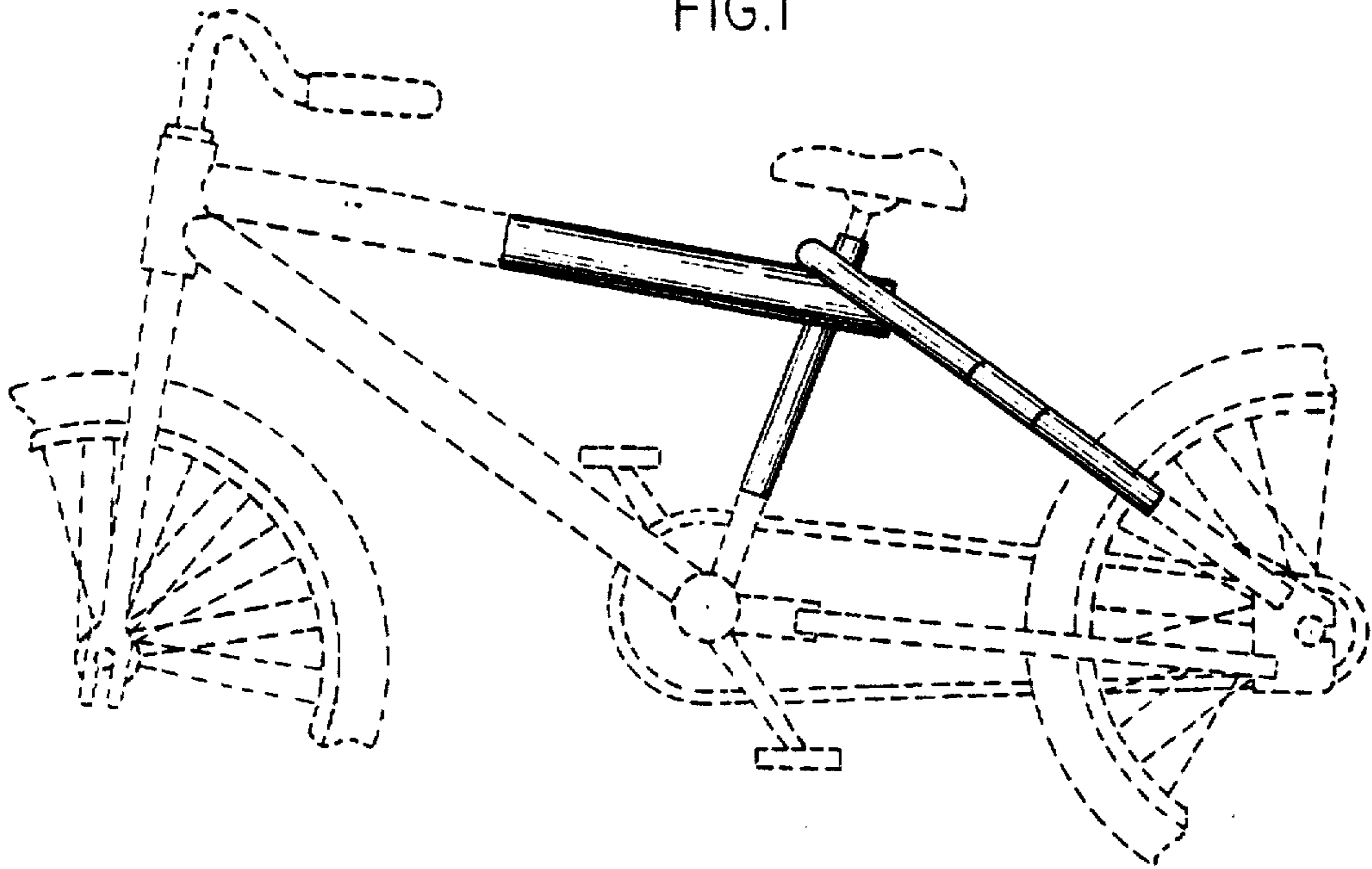

FIG. 2

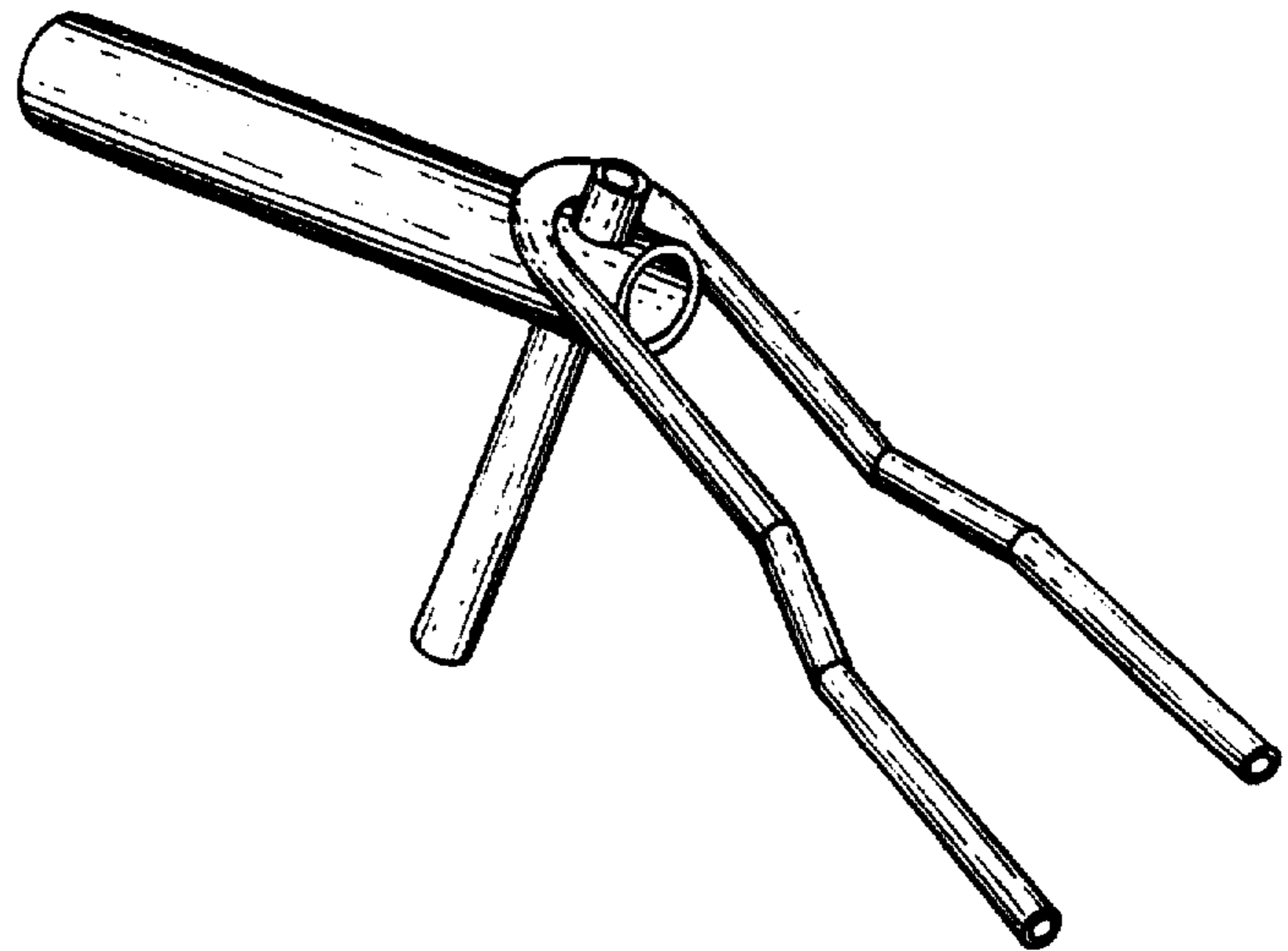

FIG. 3

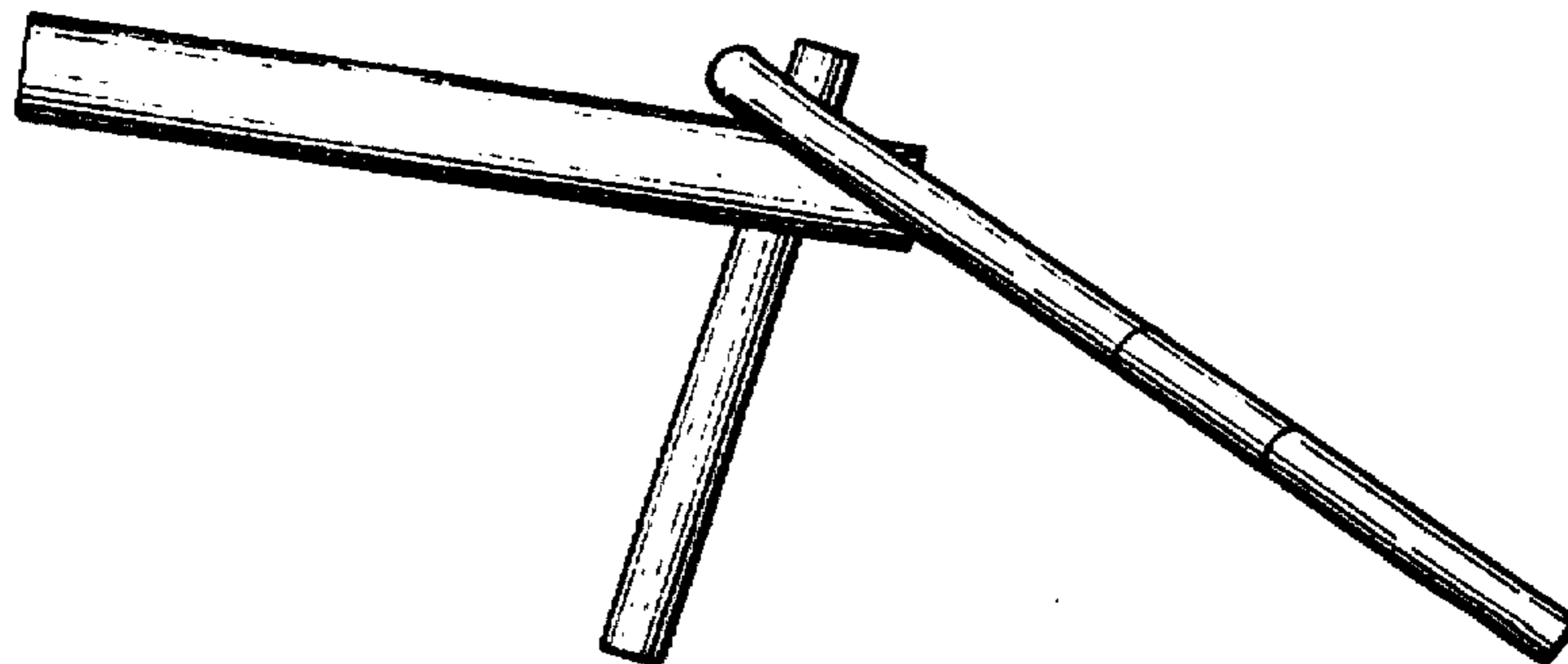

FIG. 4

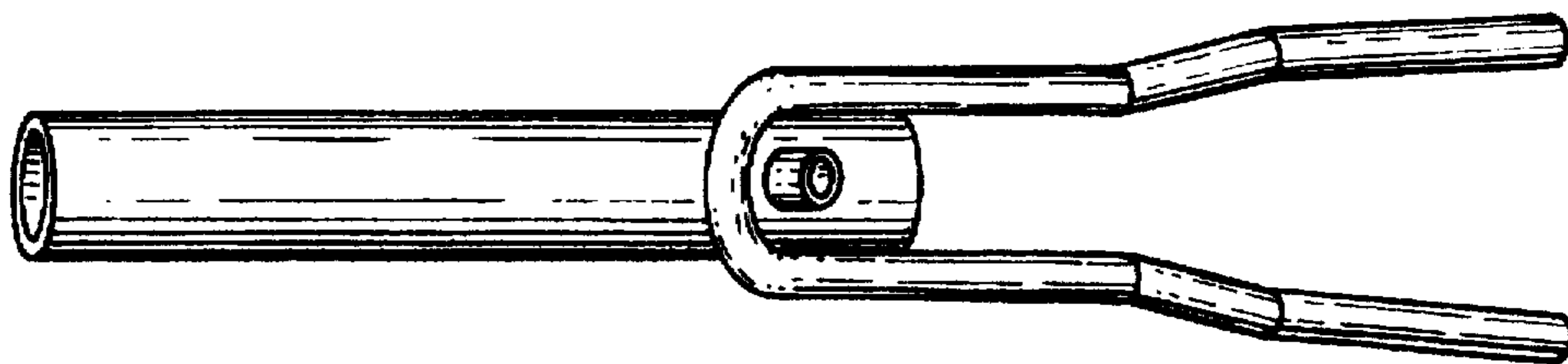

FIG. 5

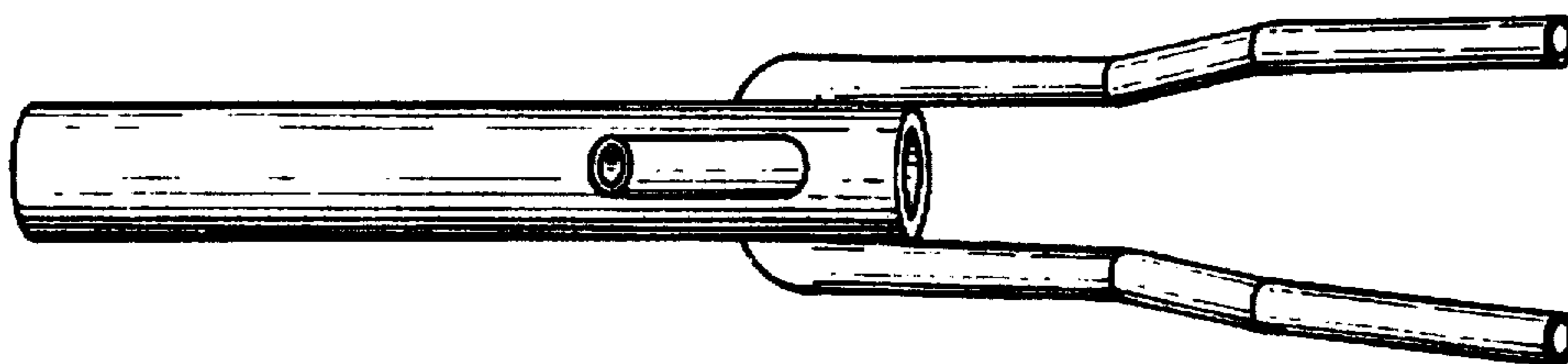

FIG. 6

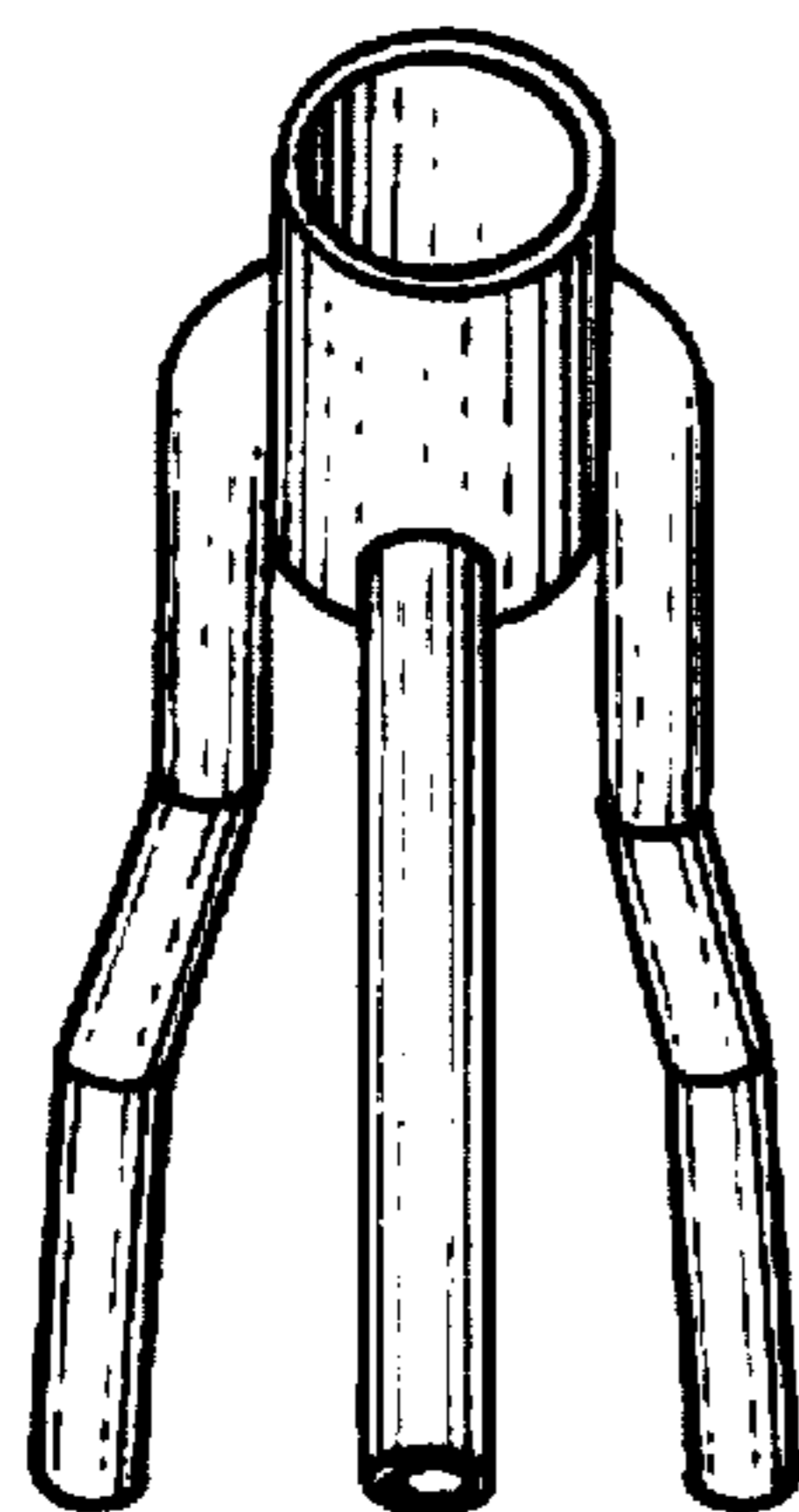

FIG. 7

