



US00D396628S

**United States Patent** [19]  
**Blanch**

[11] **Patent Number:** **Des. 396,628**  
[45] **Date of Patent:** **\*\*Aug. 4, 1998**

[54] **LATCH AND LATCH STRIKE ASSEMBLY**

[75] **Inventor:** **David Garfield Blanch**, Notting Hill,  
Australia

[73] **Assignee:** **Lockwood Australia Pty Ltd**,  
Huntingdale, Australia

[\*\*] **Term:** **14 Years**

[21] **Appl. No.:** **56,477**

[22] **Filed:** **Jul. 1, 1996**

[30] **Foreign Application Priority Data**

Jan. 25, 1996 [AU] Australia ..... 183/96

[51] **LOC (6) Cl.** ..... **08-07**

[52] **U.S. Cl.** ..... **D8/341**

[58] **Field of Search** ..... D8/330-331, 339,  
D8/341, 344; 70/104; 292/268

[56] **References Cited**

**U.S. PATENT DOCUMENTS**

D. 137,539 3/1944 Ledin ..... D8/341

D. 256,429 8/1980 Best et al. .... D8/341  
D. 284,639 7/1986 Matsuo et al. .... D8/331  
D. 297,109 8/1988 Christie ..... D8/341  
3,760,619 9/1973 Colombo ..... 70/104

*Primary Examiner*—Brian N. Vinson  
*Attorney, Agent, or Firm*—Jacobson, Price, Holman &  
Stern, PLLC

[57] **CLAIM**

The ornamental design for a latch and latch strike assembly,  
as shown and described.

**DESCRIPTION**

FIG. 1 is a front view showing my new design for a latch and  
latch strike assembly;

FIG. 2 is a top plan view thereof;

FIG. 3 is a left side view thereof;

FIG. 4 is a right side view thereof; and,

FIG. 5 is a front perspective view.

**1 Claim, 1 Drawing Sheet**

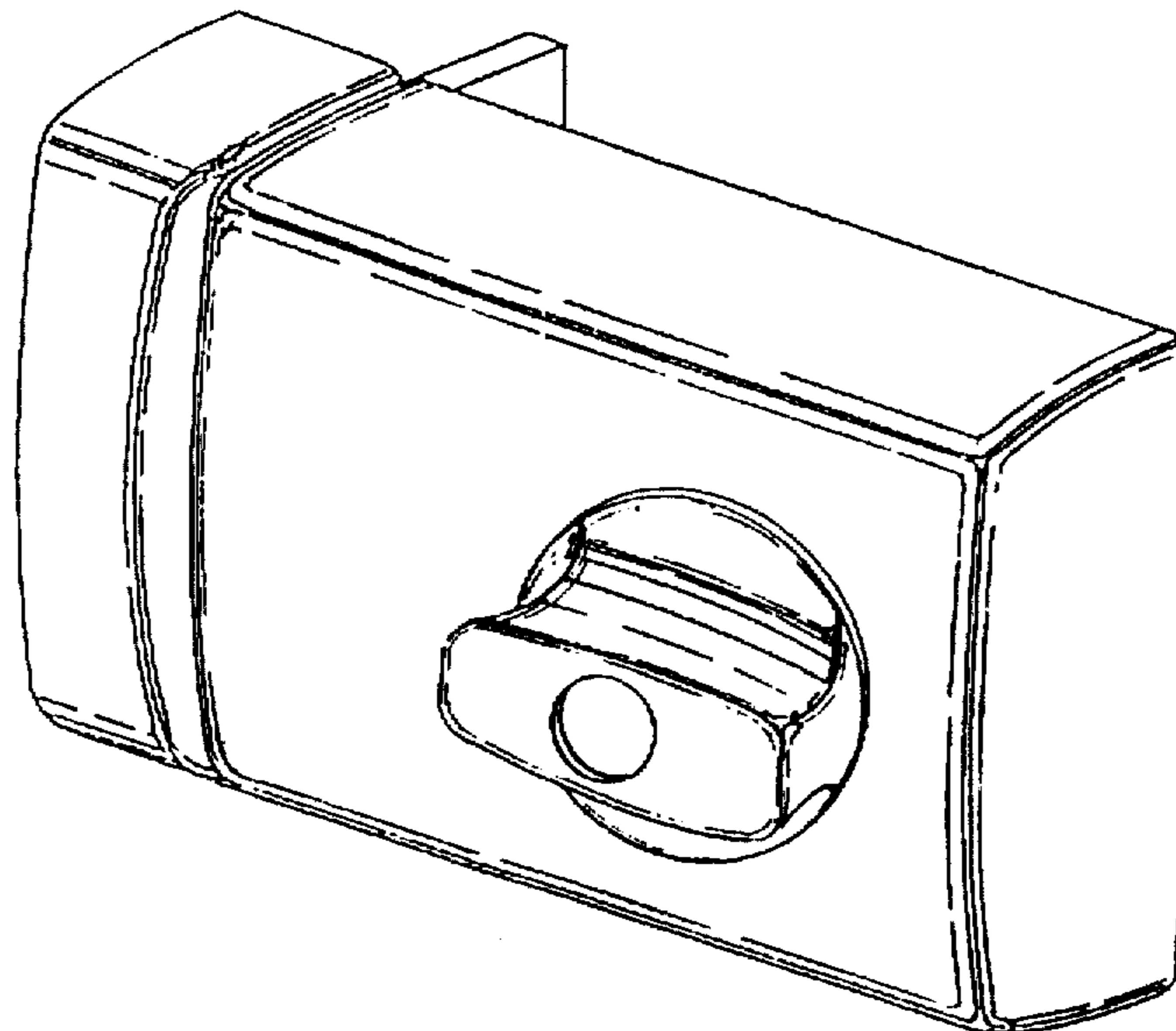

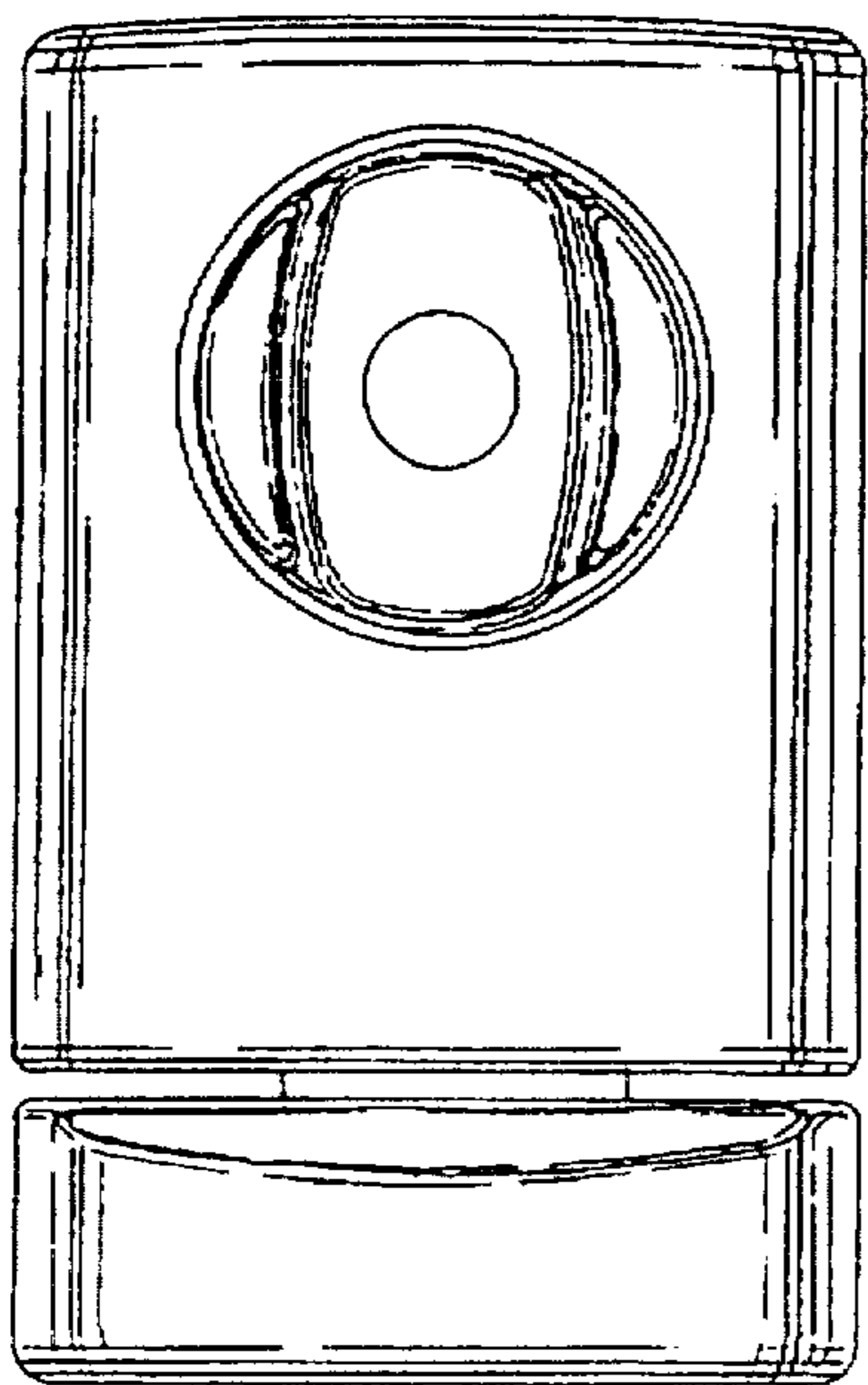

FIG 1

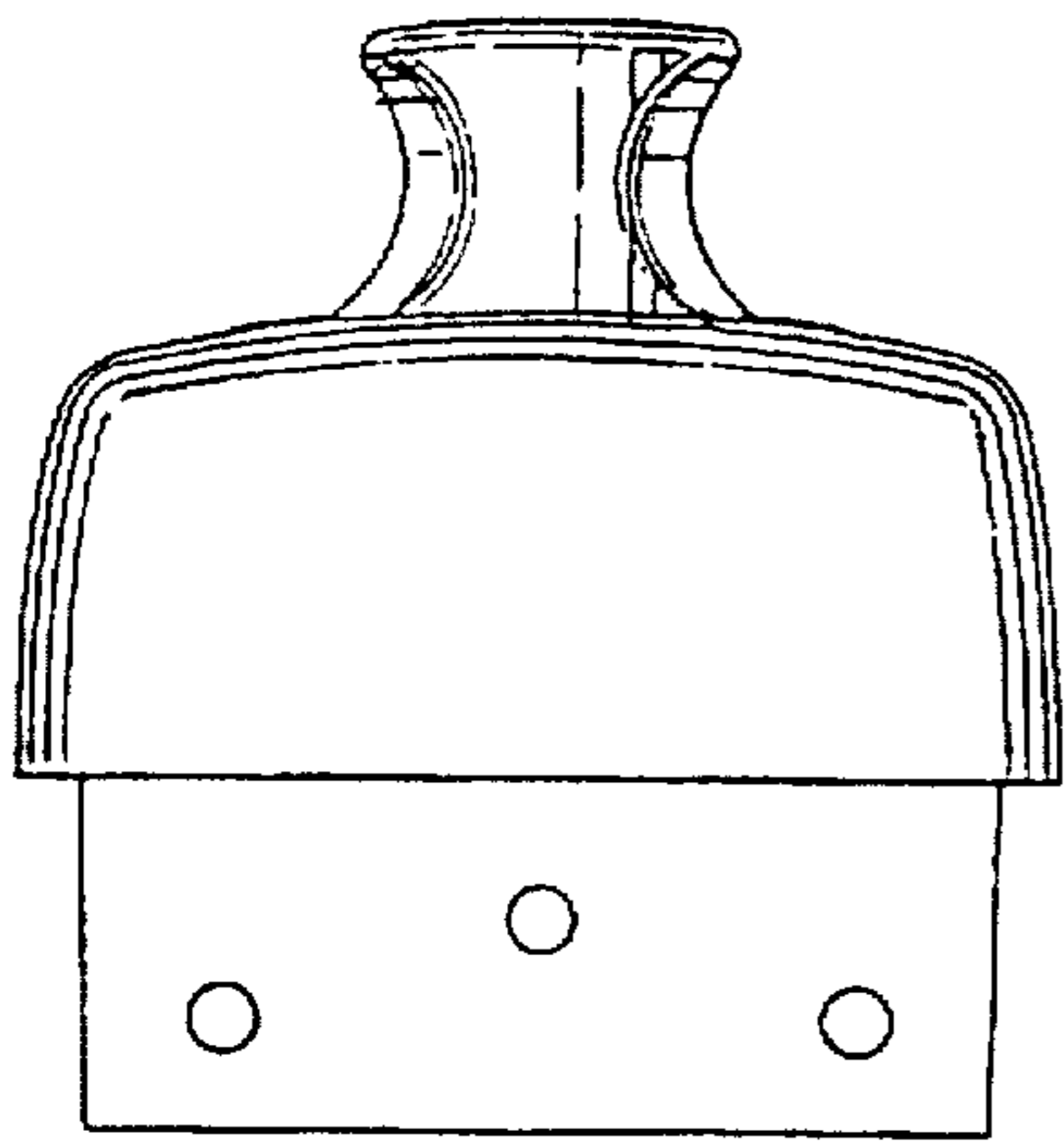

FIG 3

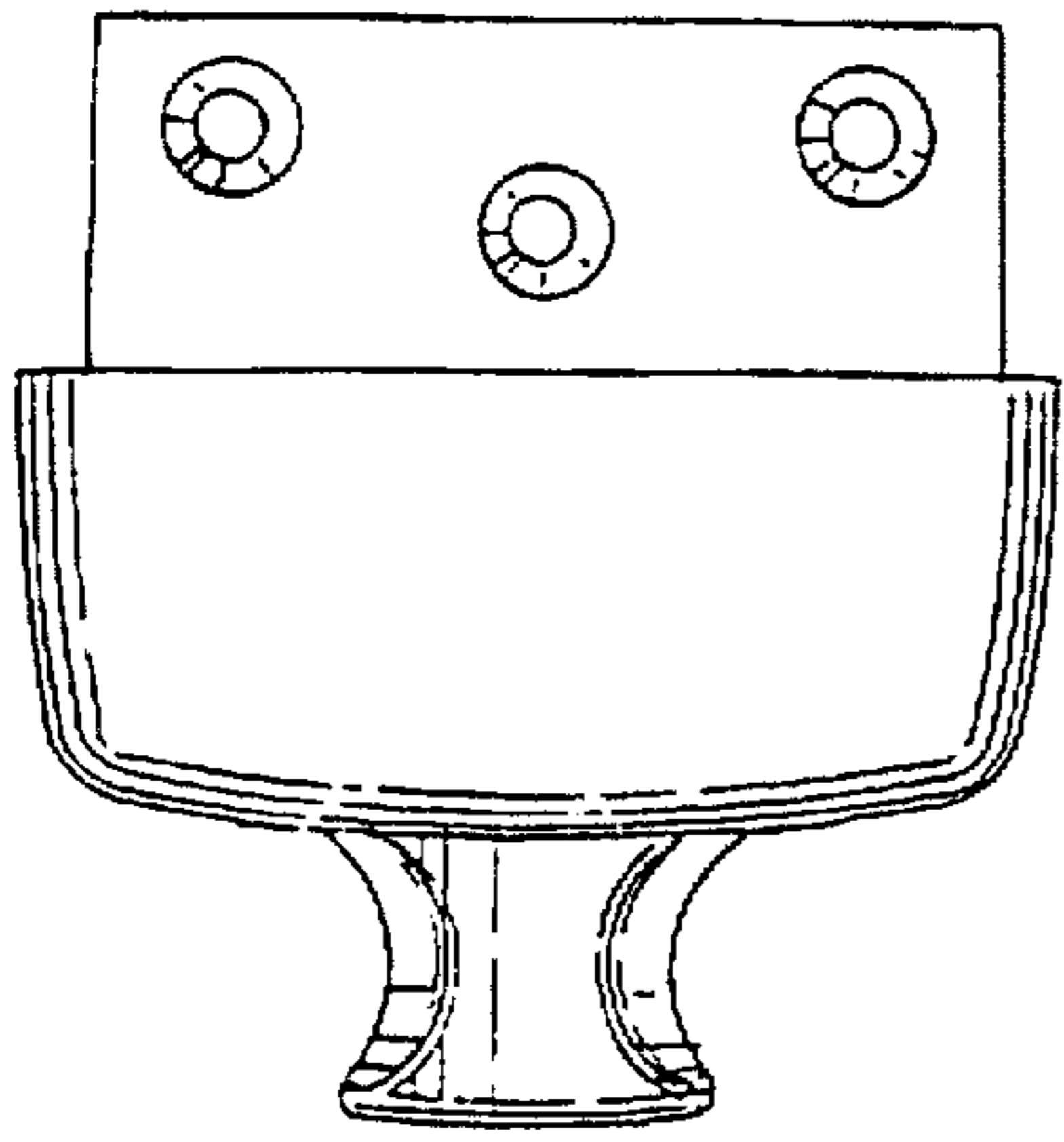

FIG 4

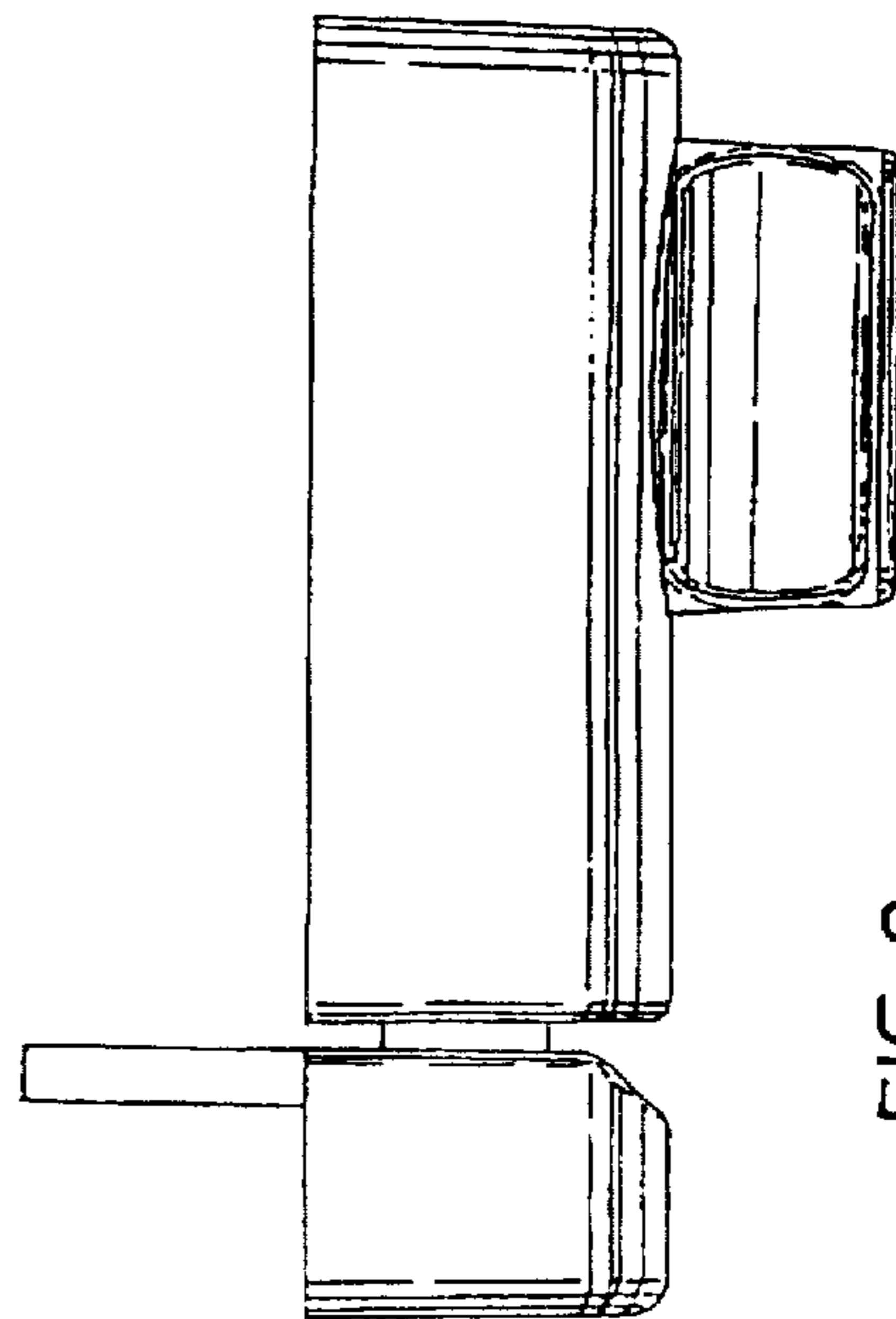

FIG 2

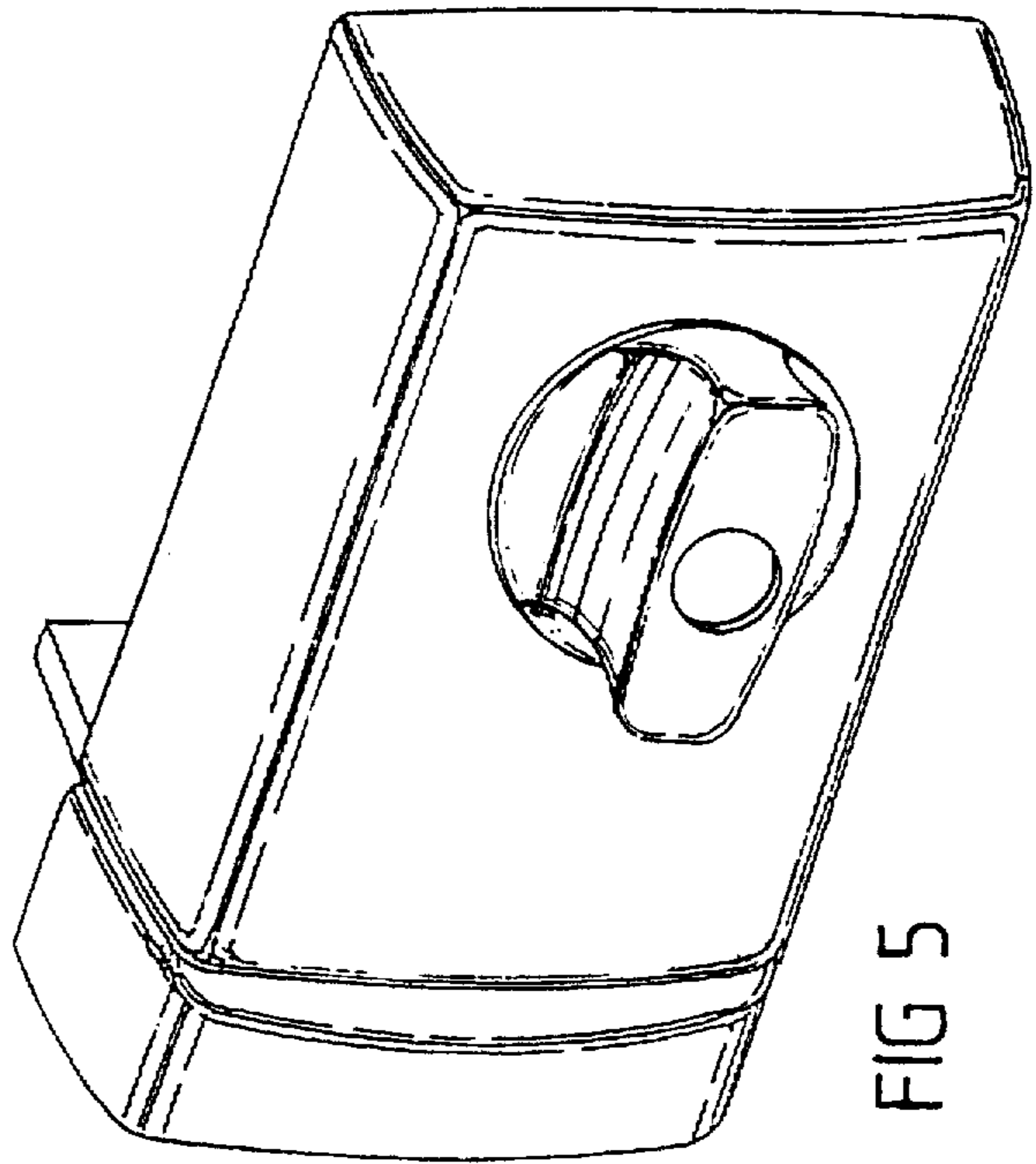

FIG 5