



US00D396445S

United States Patent [19]
Navarro-Machado

[11] **Patent Number:** **Des. 396,445**
[45] **Date of Patent:** ****Jul. 28, 1998**

[54] **PASSENGER AIRCRAFT**

5,289,995 3/1994 Greene D12/333

[76] **Inventor:** **Manuel Navarro-Machado**, 1803 SW.
104 Pl., Miami, Fla. 33165

Primary Examiner—Kay H. Chin
Attorney, Agent, or Firm—J. Sanchelima

[**] **Term:** **14 Years**

[57] **CLAIM**

[21] **Appl. No.:** **73,040**

The ornamental design for a passenger aircraft, as shown and described.

[22] **Filed:** **Jun. 27, 1997**

DESCRIPTION

[51] **LOC (6) Cl.** **12-07**

[52] **U.S. Cl.** **D12/333; D12/331; D12/319**

[58] **Field of Search** **D12/319-345;**
244/153 R, 153 A, 154, 185, 15, 52, 36,
53 B

FIG. 1 is a top plan view of a passenger aircraft, showing my new design;

FIG. 2 is an elevational left side view thereof;

FIG. 3 is a bottom plan view thereof;

FIG. 4 is an elevational view thereof;

FIG. 5 is an elevational right side view thereof;

FIG. 6 is an elevational rear view thereof;

FIG. 7 is a top perspective view thereof; and,

FIG. 8 is a bottom perspective view thereof.

[56] **References Cited**

U.S. PATENT DOCUMENTS

- D. 291,215 8/1987 Arata, Jr. D12/333
- D. 294,478 3/1988 Asdurian et al. D12/319
- D. 332,080 12/1992 Sandusky, Jr. et al. D12/331

1 Claim, 3 Drawing Sheets

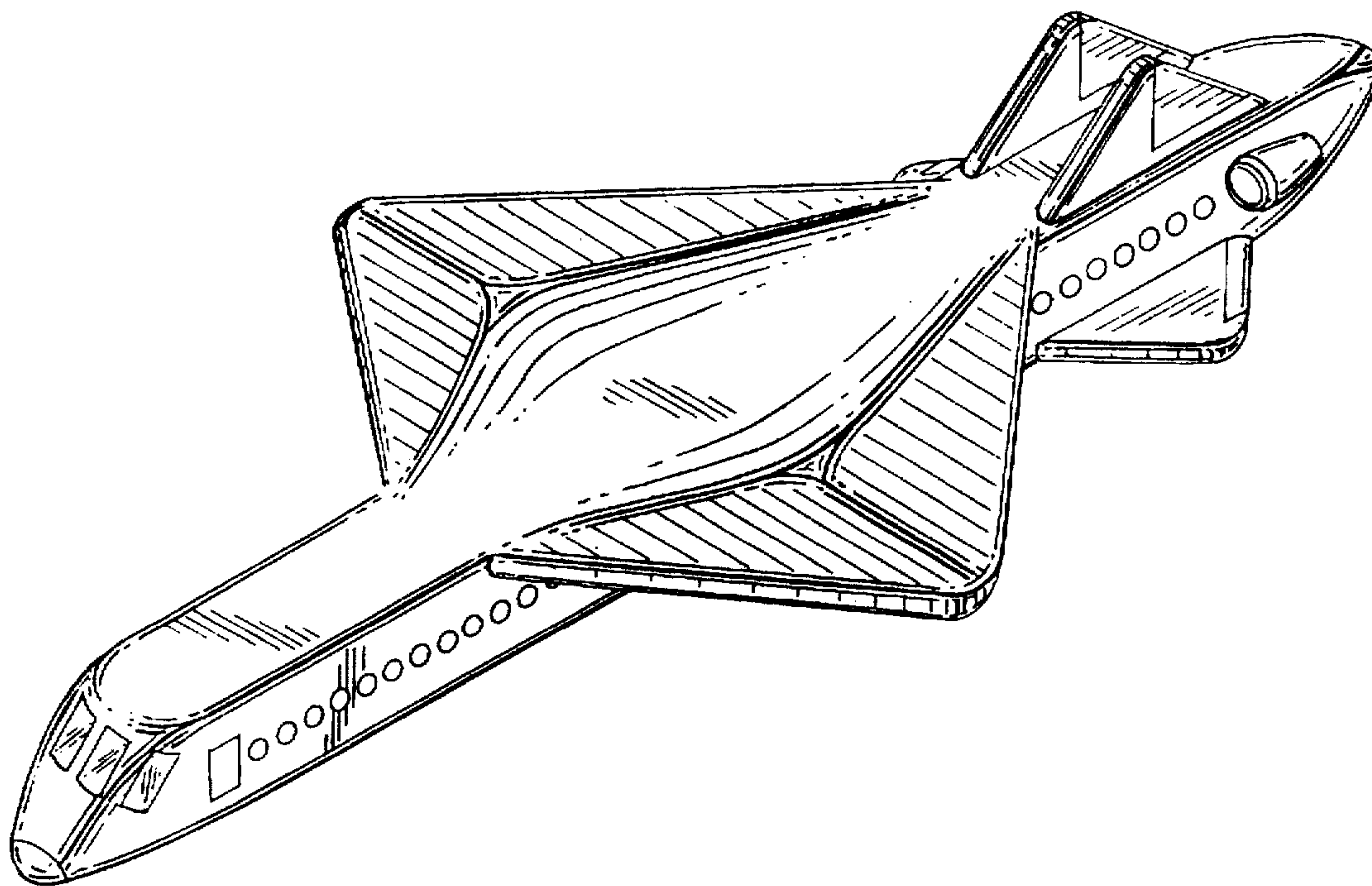

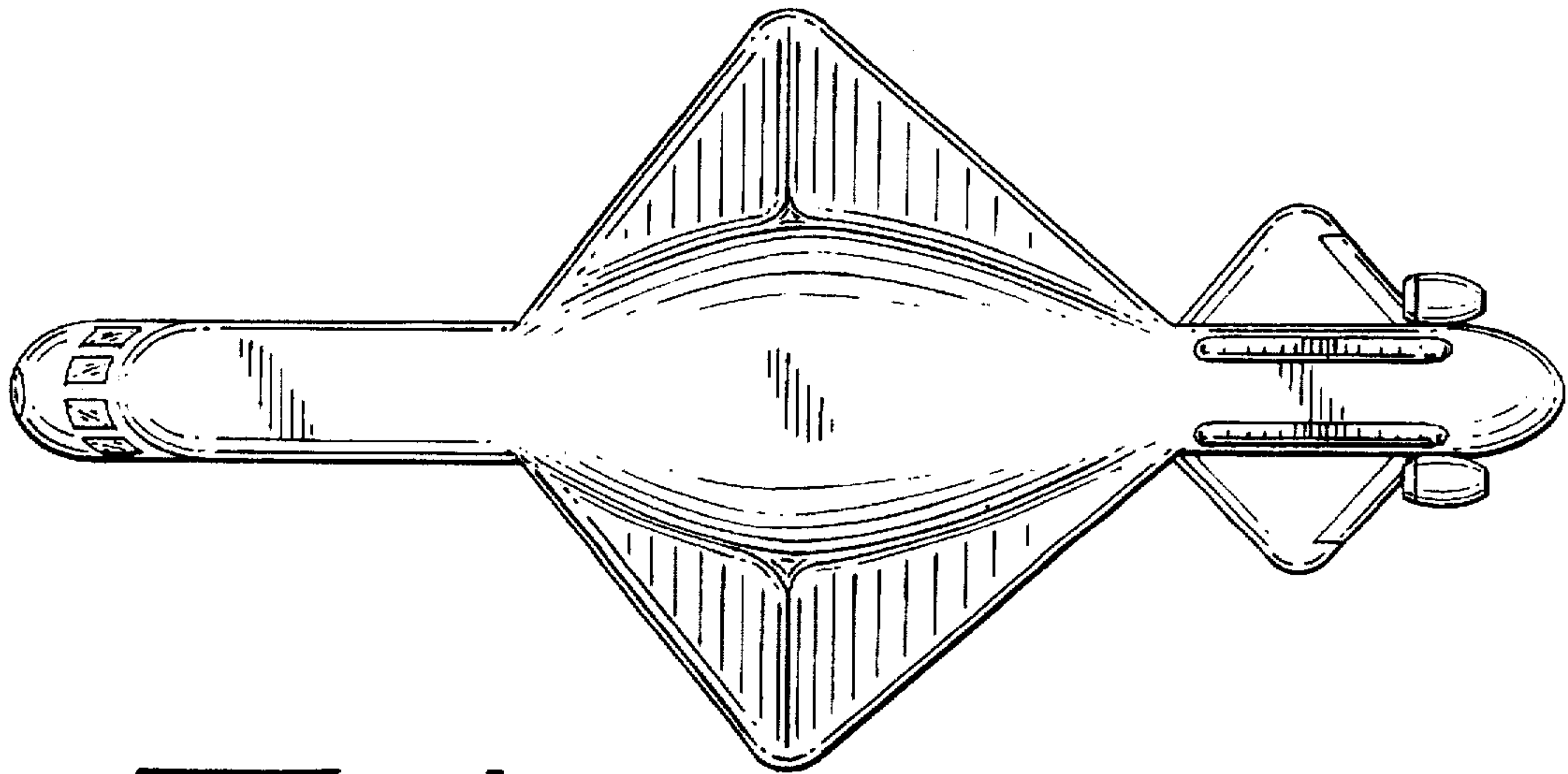

FIG. 1.

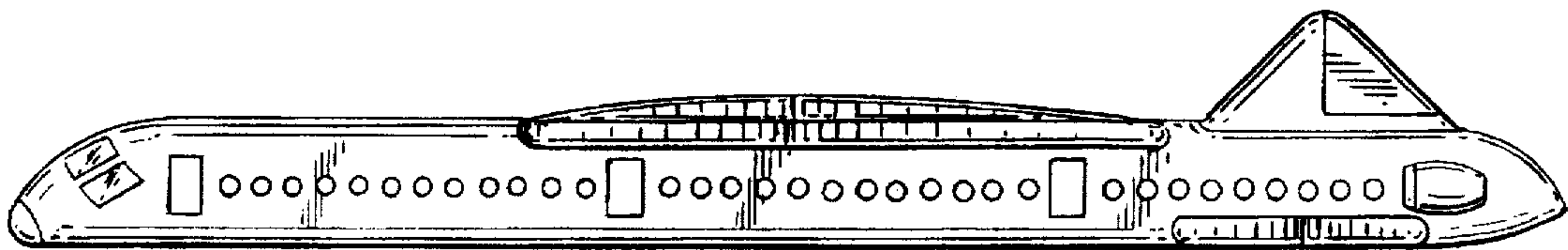

FIG. 2.

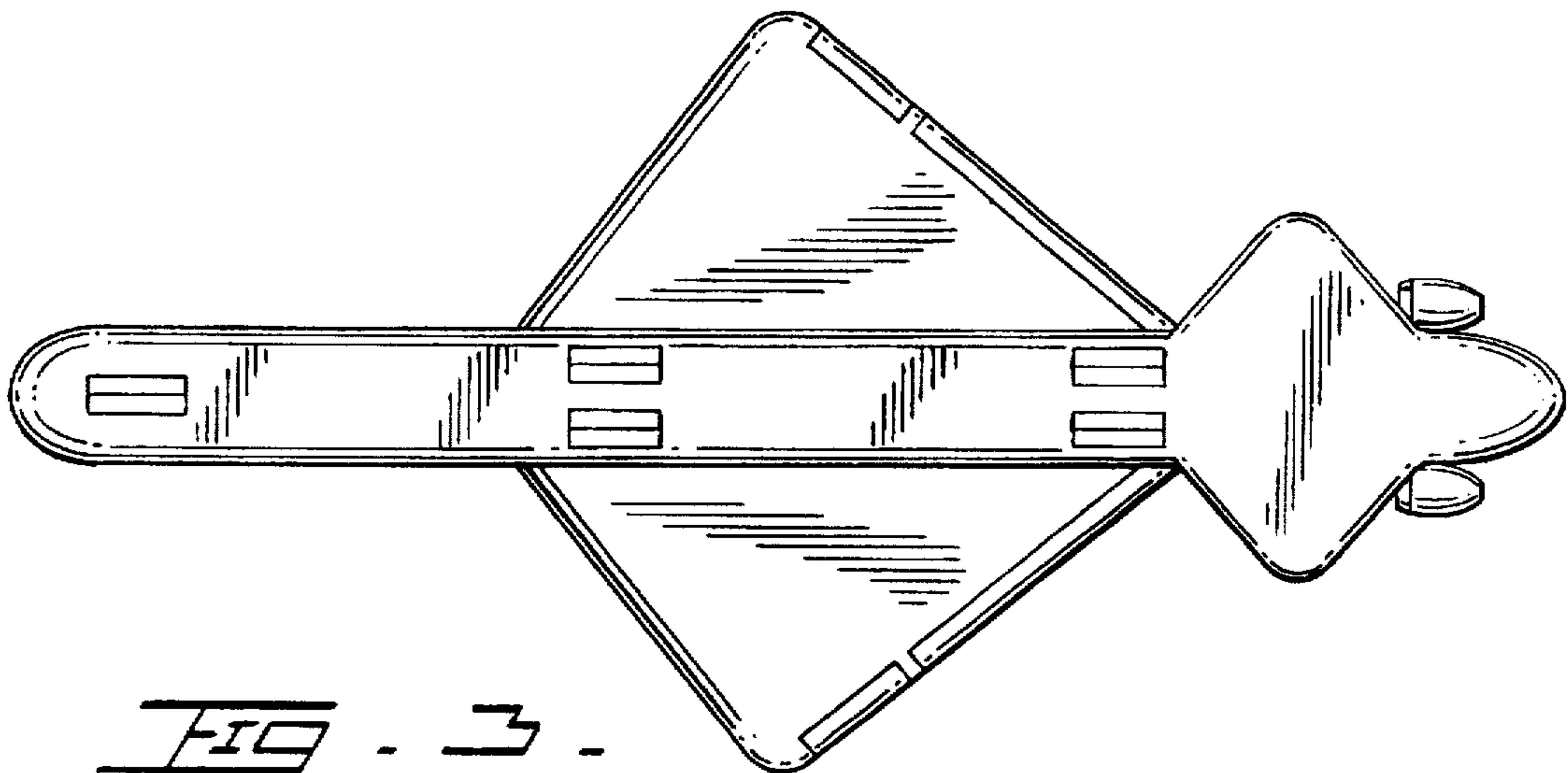

FIG. 3.

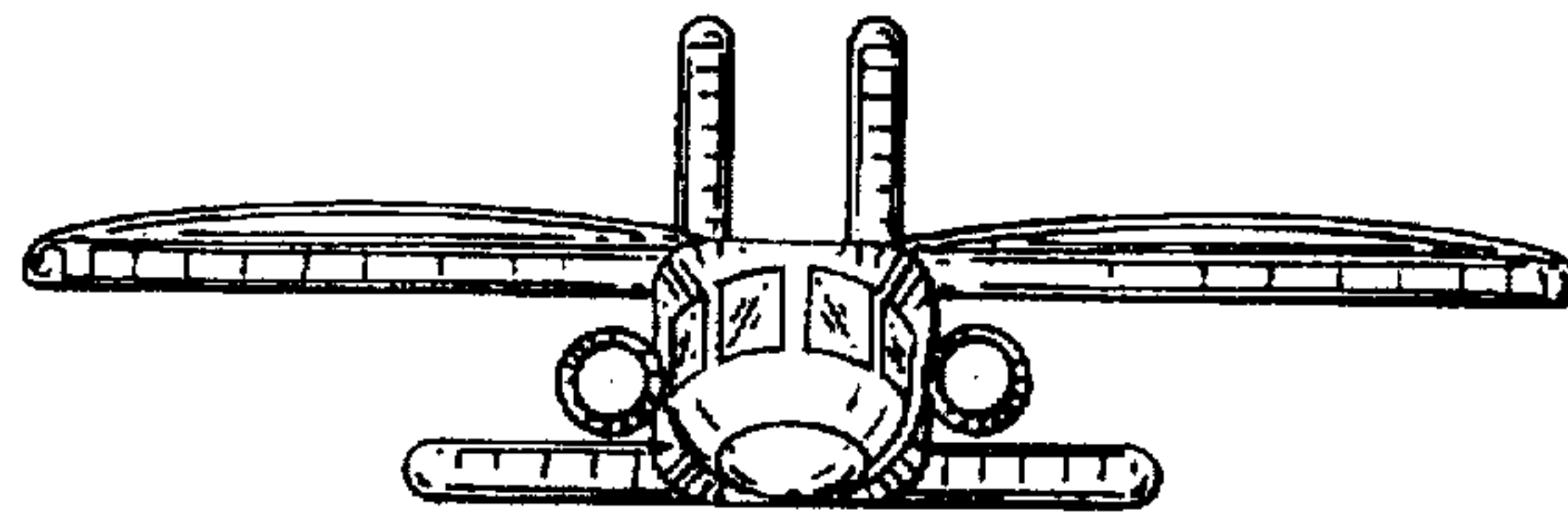

FIG. 4.

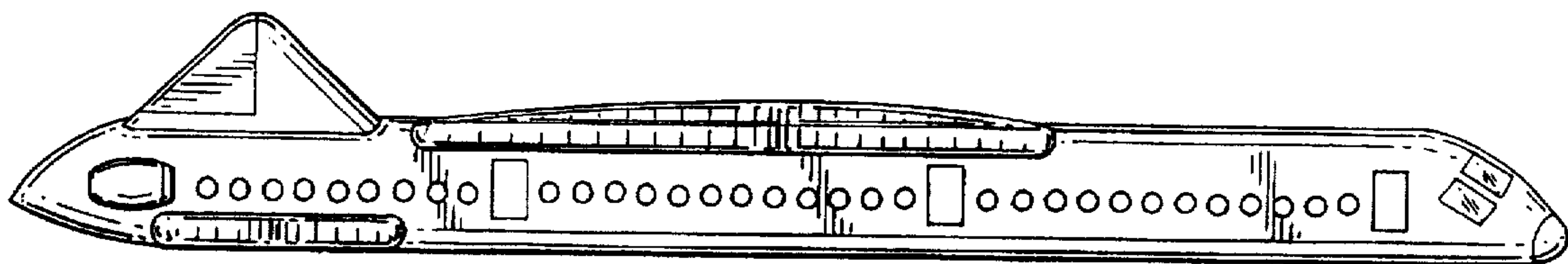

FIG. 5.

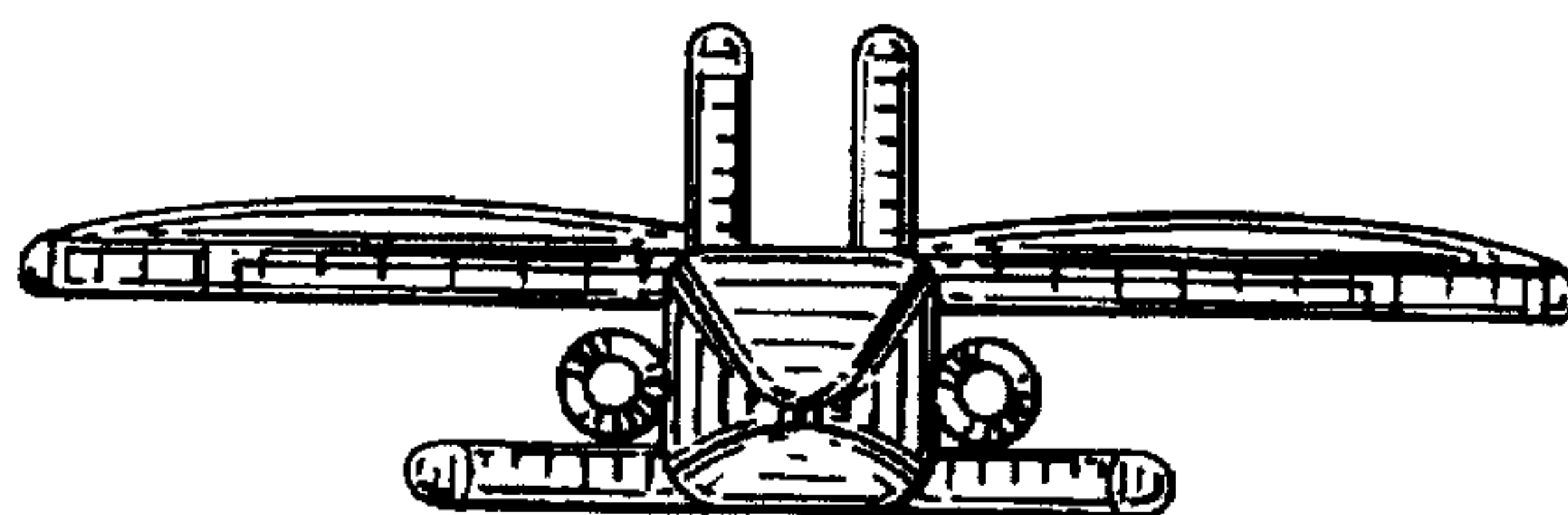

FIG. 6.

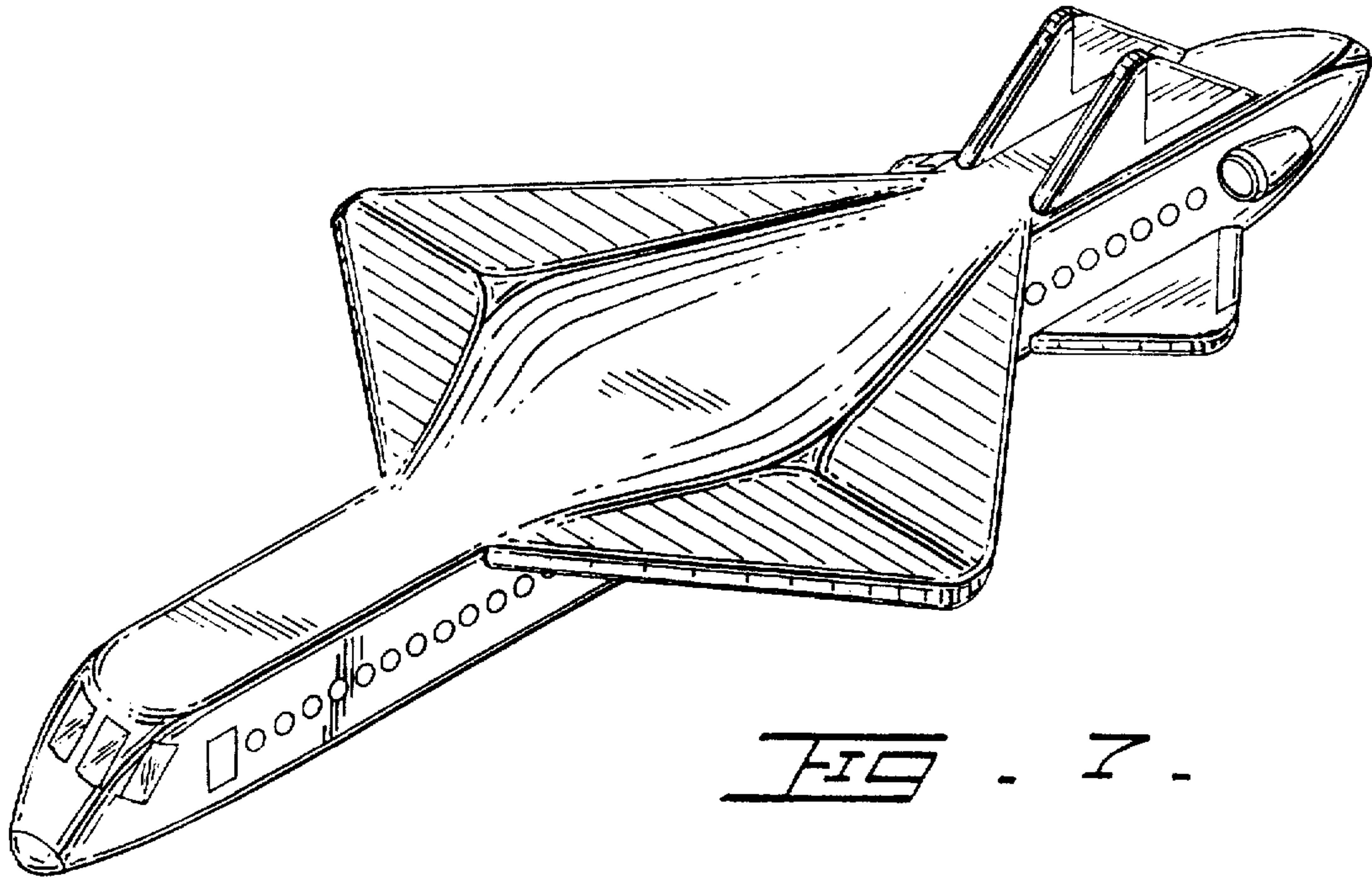

FIG. 1.

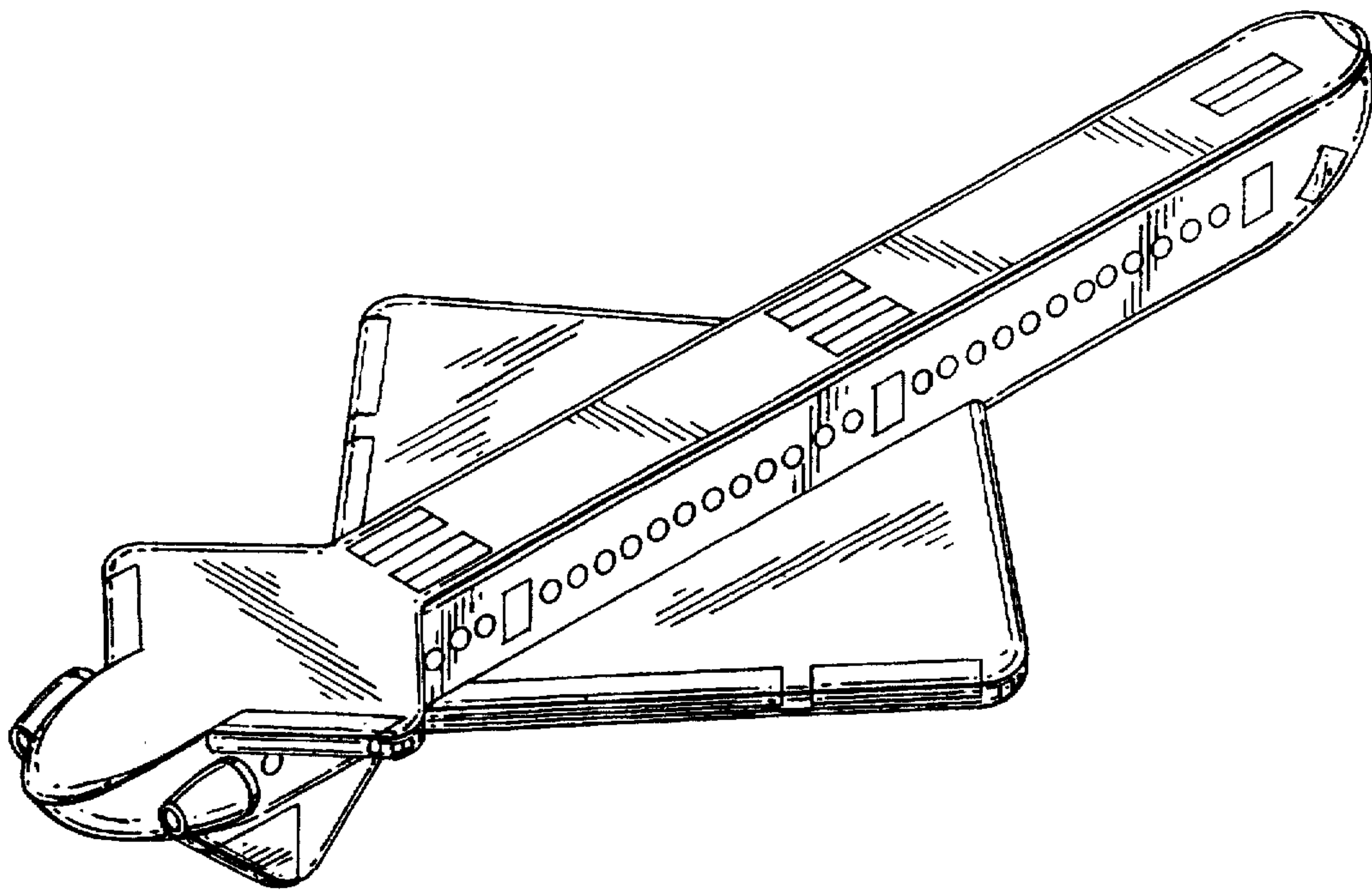

FIG. 2.