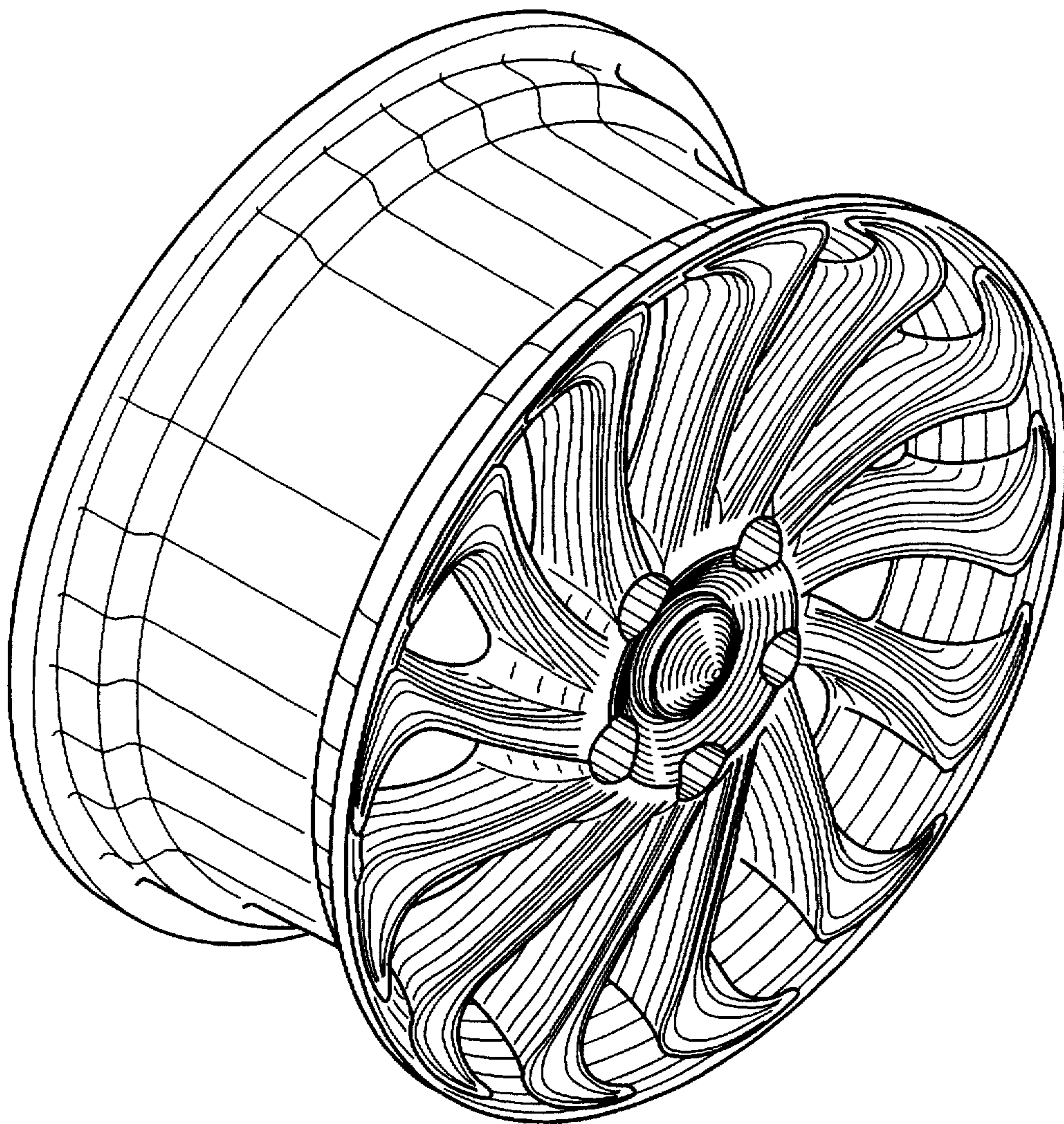

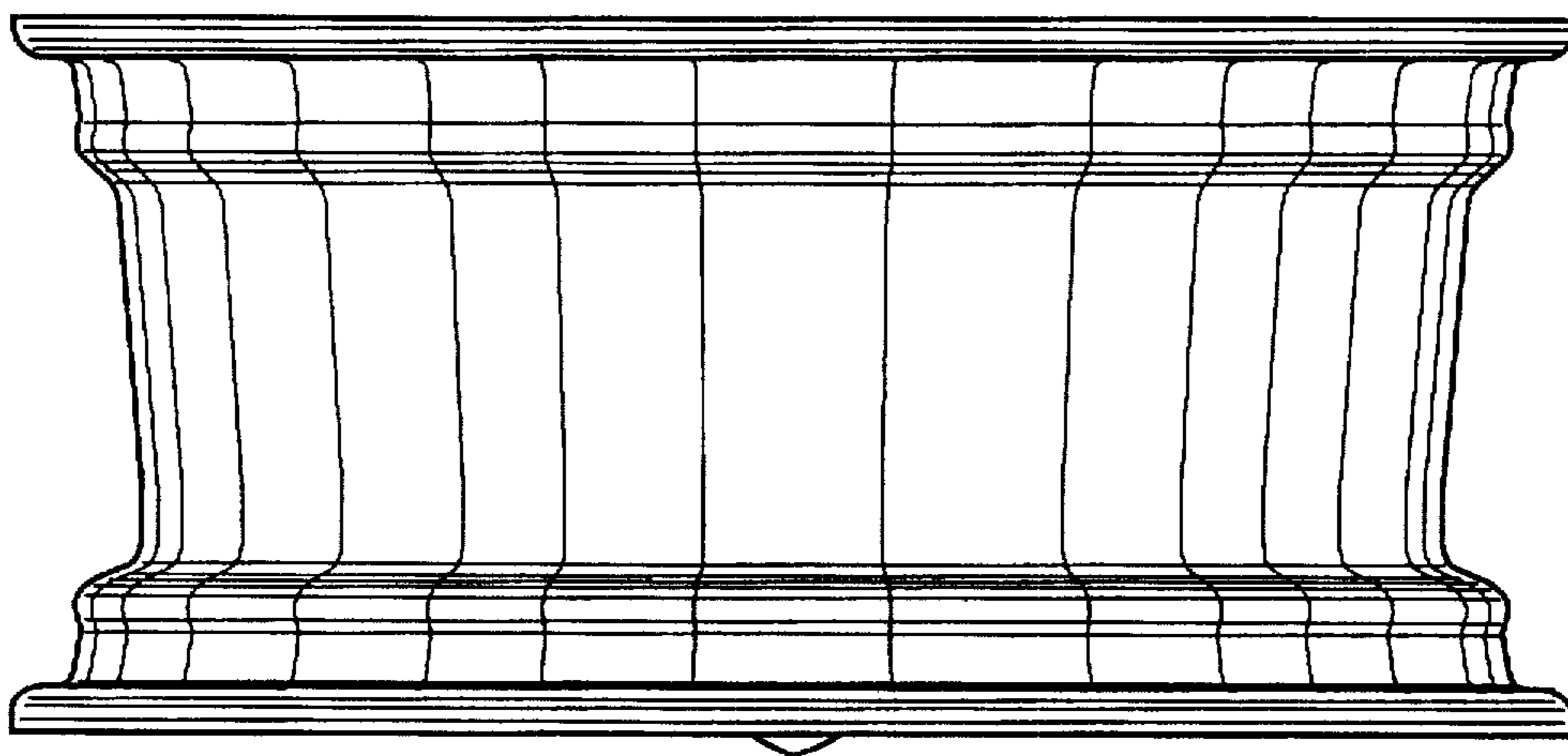

**FIG. 1**

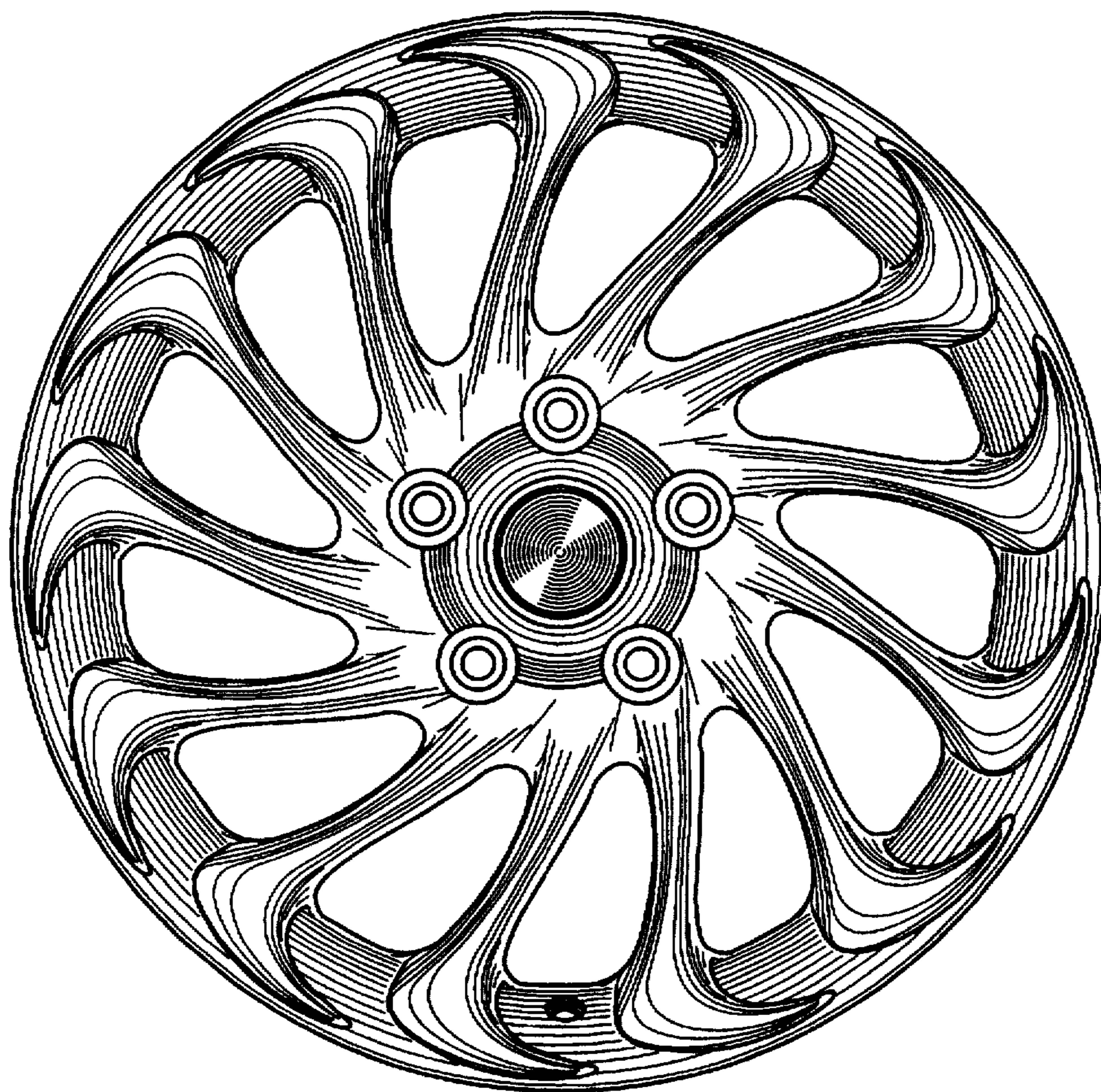



**FIG.3**



**FIG.2**



**FIG.6**

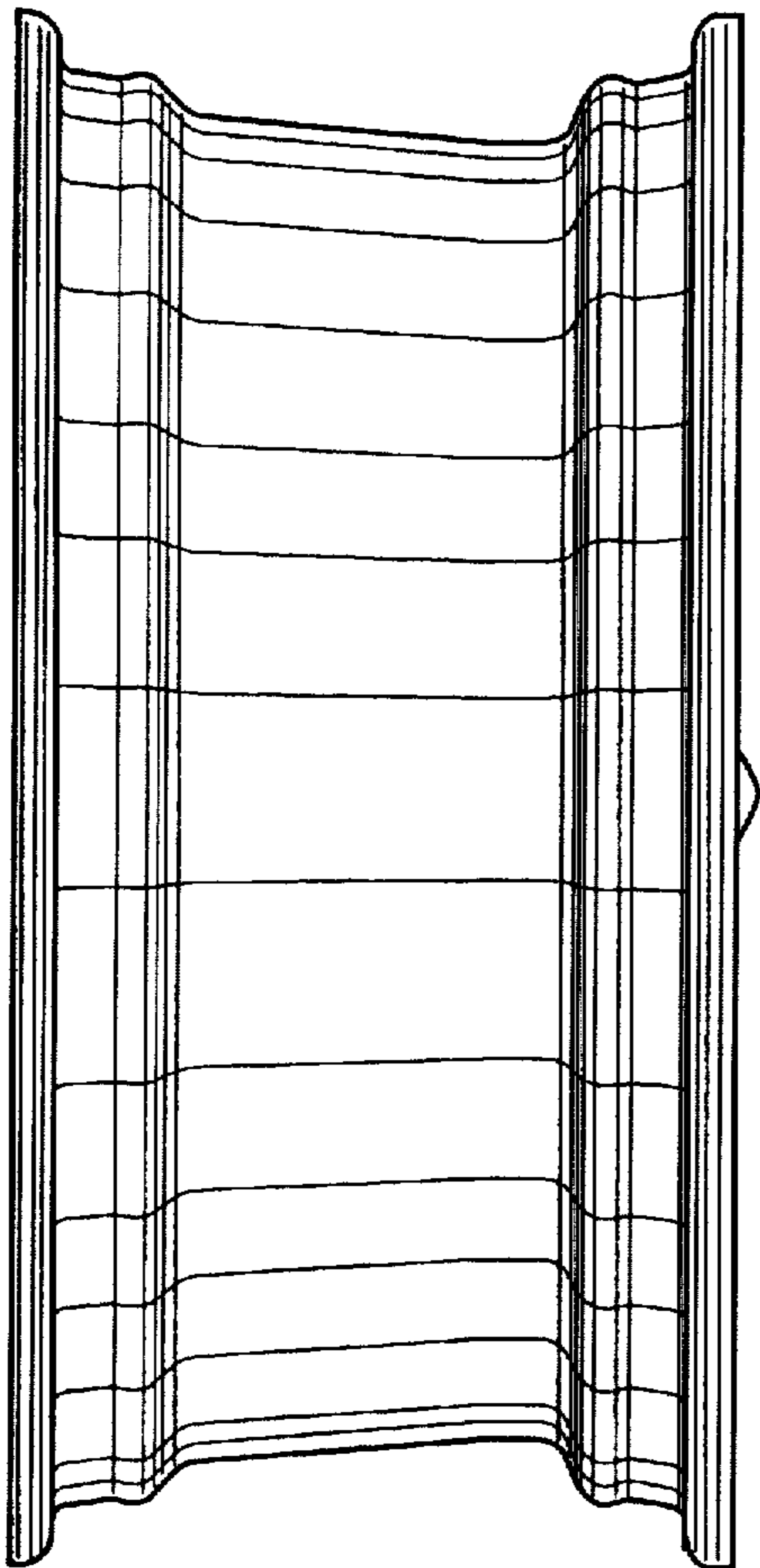

**FIG.5**

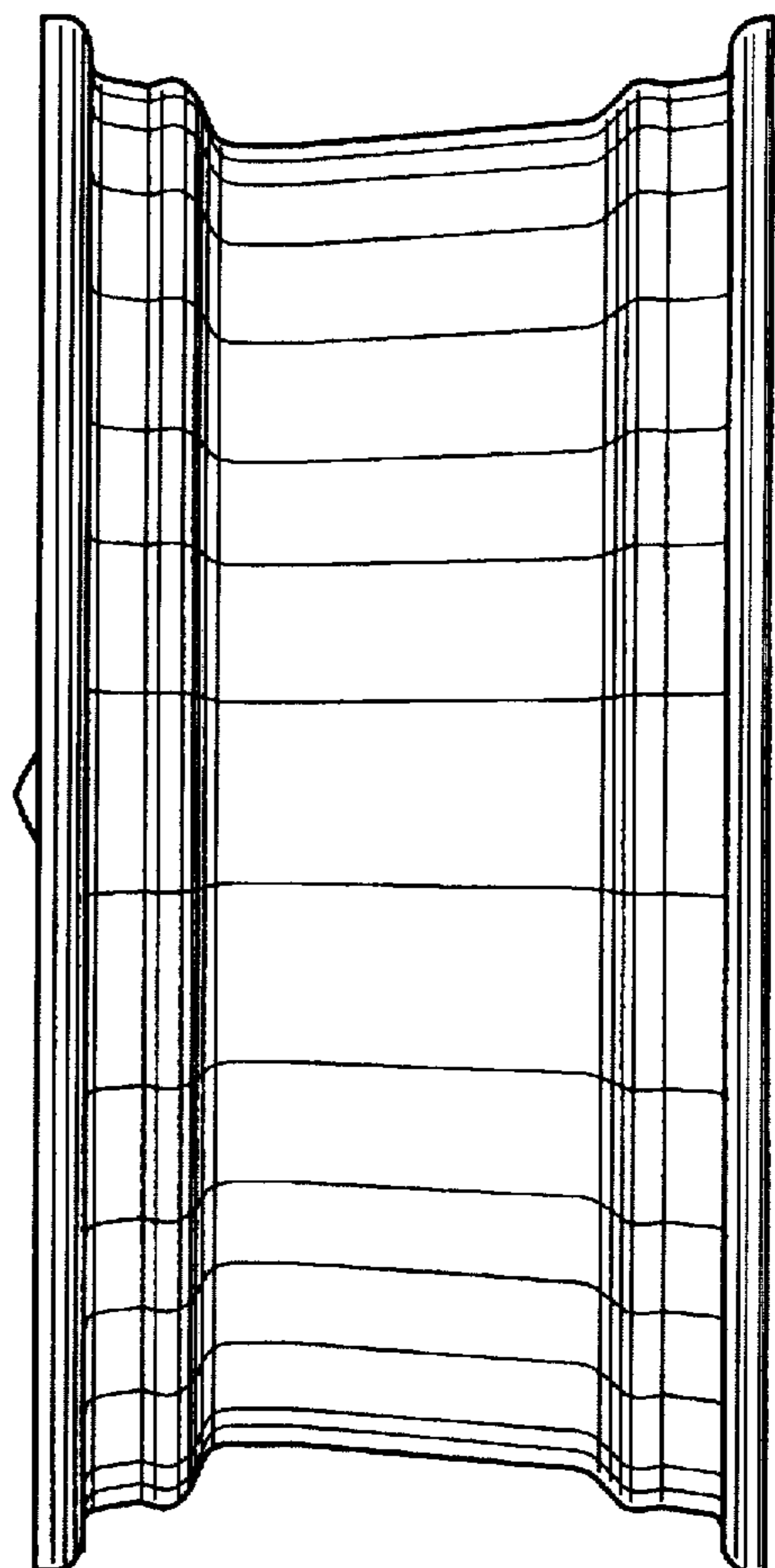

**FIG.4**

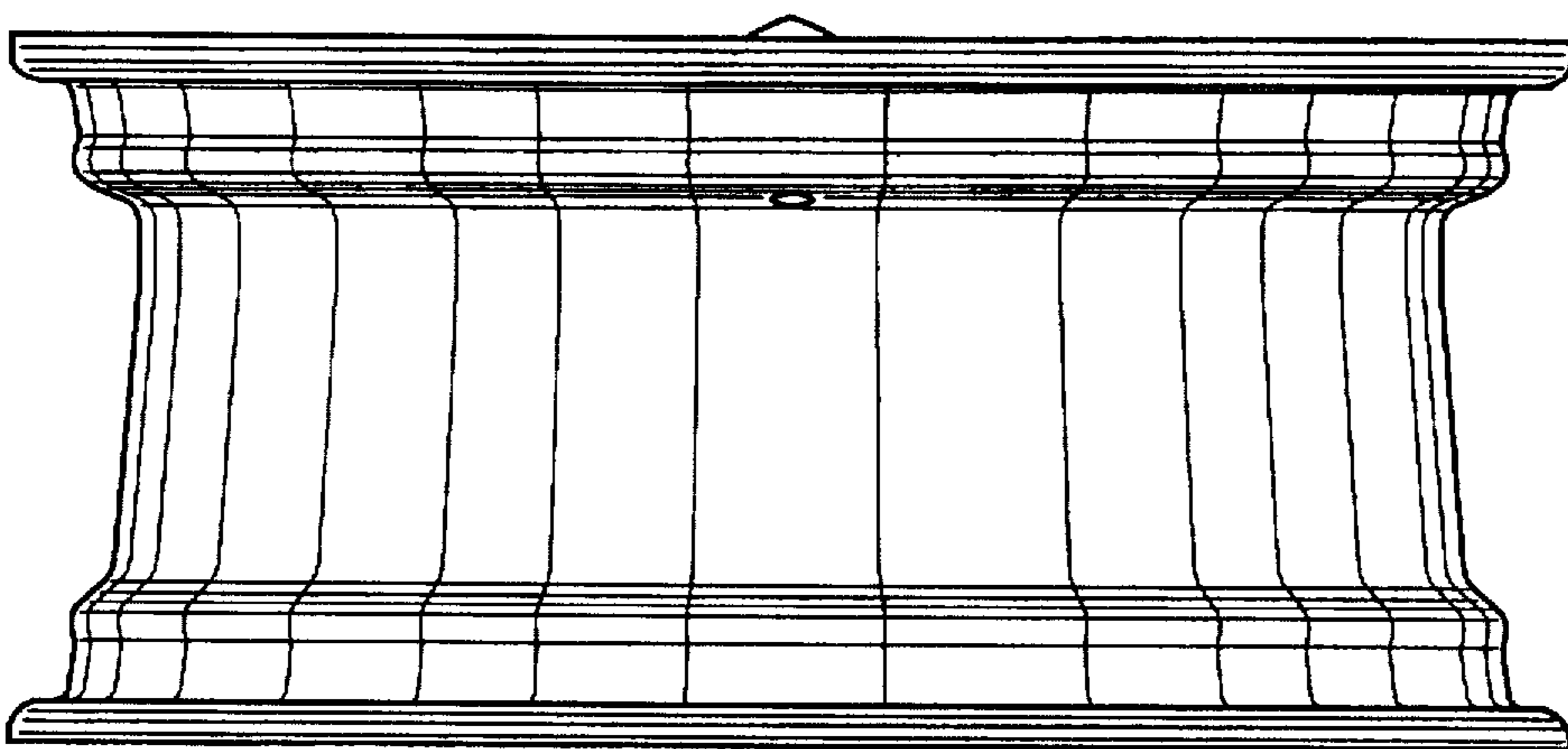

UNITED STATES PATENT AND TRADEMARK OFFICE  
**CERTIFICATE OF CORRECTION**

PATENT NO. : **D396441**  
DATED : **July 28, 1998**  
INVENTOR(S) : **Nobuo NISHIDA**

It is certified that error appears in the above-identified patent and that said Letters Patent is hereby corrected as shown below:

On the title page, Item [73] Assignee, **"Kabushiki Kaishi  
Crimson to --Kabushiki Kaisha Crimson--.**  
**Please change the filing date (22) from "May 23, 1997" to  
--May 20, 1997--.**

Signed and Sealed this  
Eleventh Day of May, 1999

*Attest:*



**Q. TODD DICKINSON**

*Attesting Officer*

*Acting Commissioner of Patents and Trademarks*