



US00D396282S

United States Patent [19]

Schulze

[11] Patent Number: Des. 396,282

[45] Date of Patent: **Jul. 21, 1998

[54] VEHICLE RESTRAINT SERVICE JOCKEY

[76] Inventor: Todd B. Schulze, 842 37th St. SE., Buffalo, Minn. 55313

[**] Term: 14 Years

[21] Appl. No.: 71,048

[22] Filed: May 16, 1997

[51] LOC (6) Cl. 12-05

[52] U.S. Cl. D34/33

[58] Field of Search D34/28, 34, 35, D34/33; 254/8 B, 8 R, 84, 426, 11, 93 H, 88, DIG. 1

[56] **References Cited**

U.S. PATENT DOCUMENTS

D. 274,571	7/1984	Vermette	D34/33
D. 376,240	12/1996	Finnigan et al.	D34/33
3,391,956	7/1968	Hawkins	254/8 B
4,421,209	12/1983	Vermette et al.	254/11
4,508,233	4/1985	Helms	D34/33

4,588,165	5/1986	Stellato	D34/33
4,749,324	6/1988	Rulison	D34/33
4,856,767	8/1989	Wood	254/88
5,076,448	12/1991	Ballard	D34/33

Primary Examiner—Alan P. Douglas
Assistant Examiner—Robin V. Taylor
Attorney, Agent, or Firm—Malcolm Reid

[57] **CLAIM**

The ornamental design for a vehicle restraint service jockey, as shown.

DESCRIPTION

FIG. 1 is a rear elevational view of a vehicle restraint service jockey;
FIG. 2 is a right side elevational view thereof;
FIG. 3 is a left side elevational view thereof;
FIG. 4 is a front elevational view thereof;
FIG. 5 is a top plan view thereof; and,
FIG. 6 is a bottom plan view thereof.

1 Claim, 6 Drawing Sheets

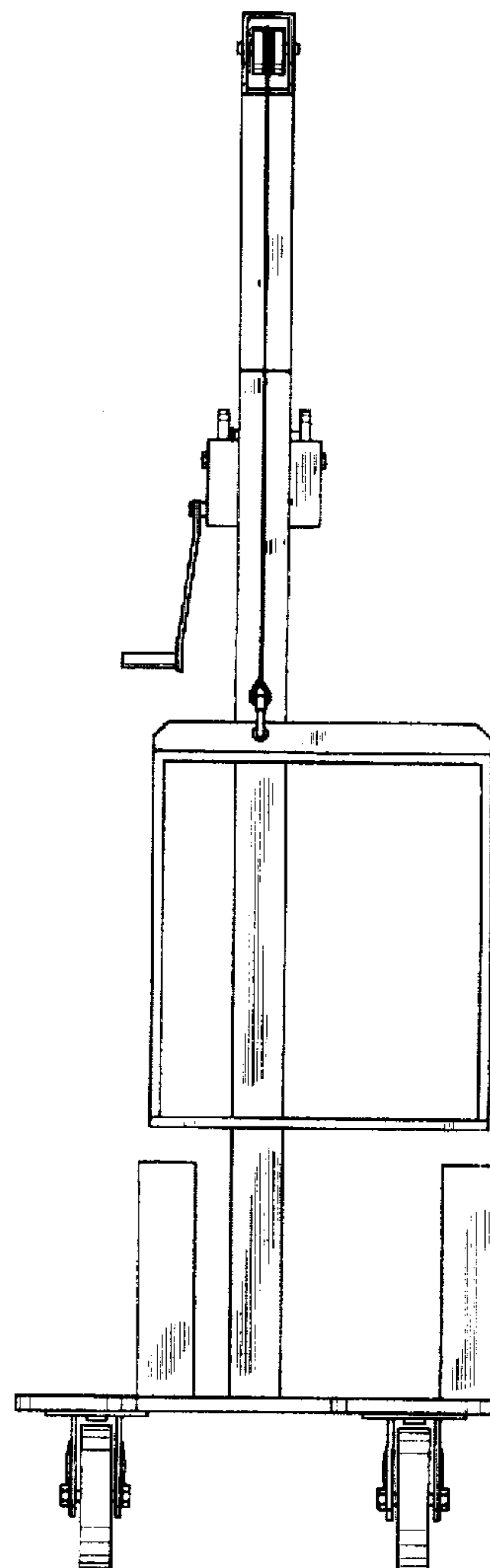
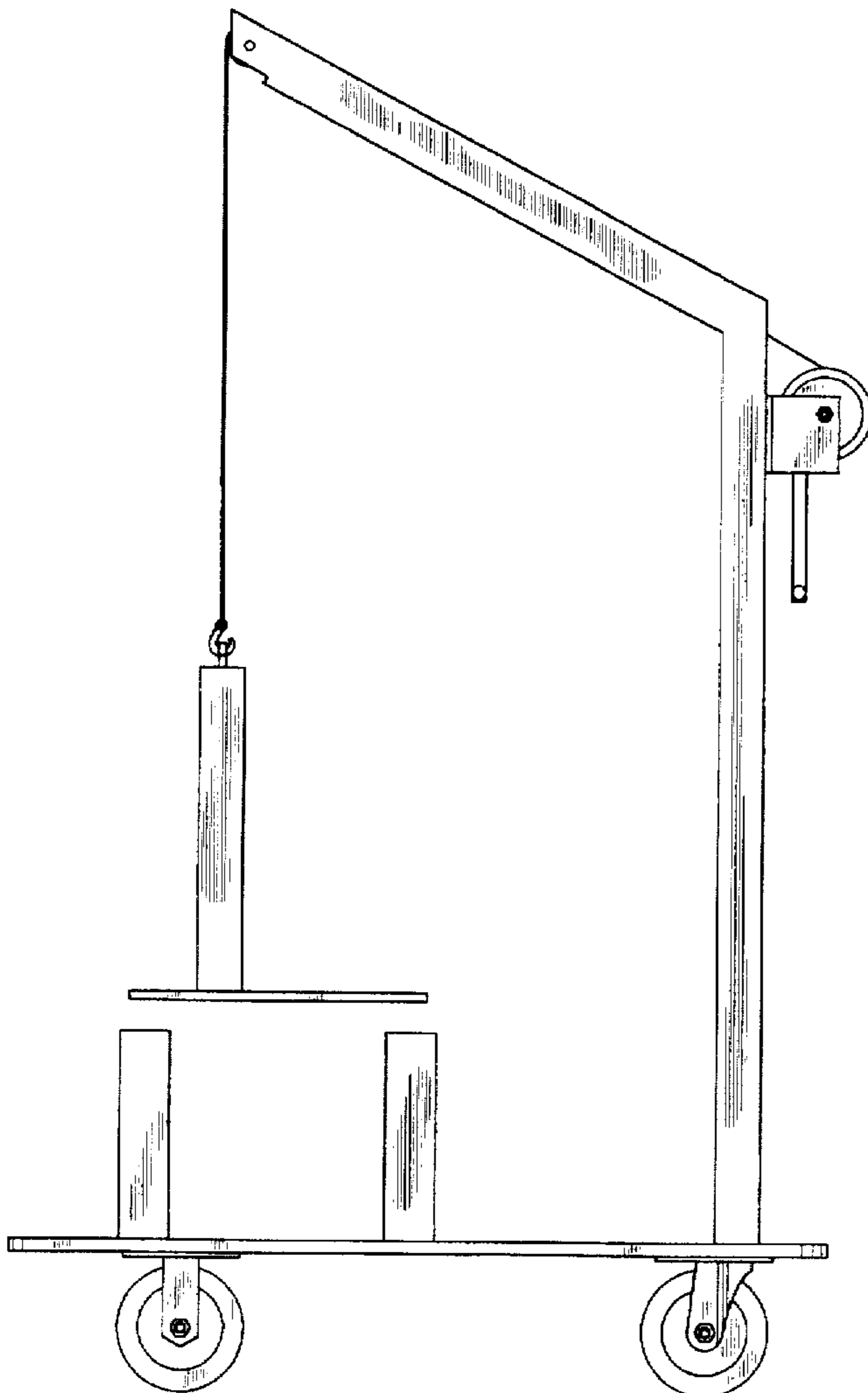

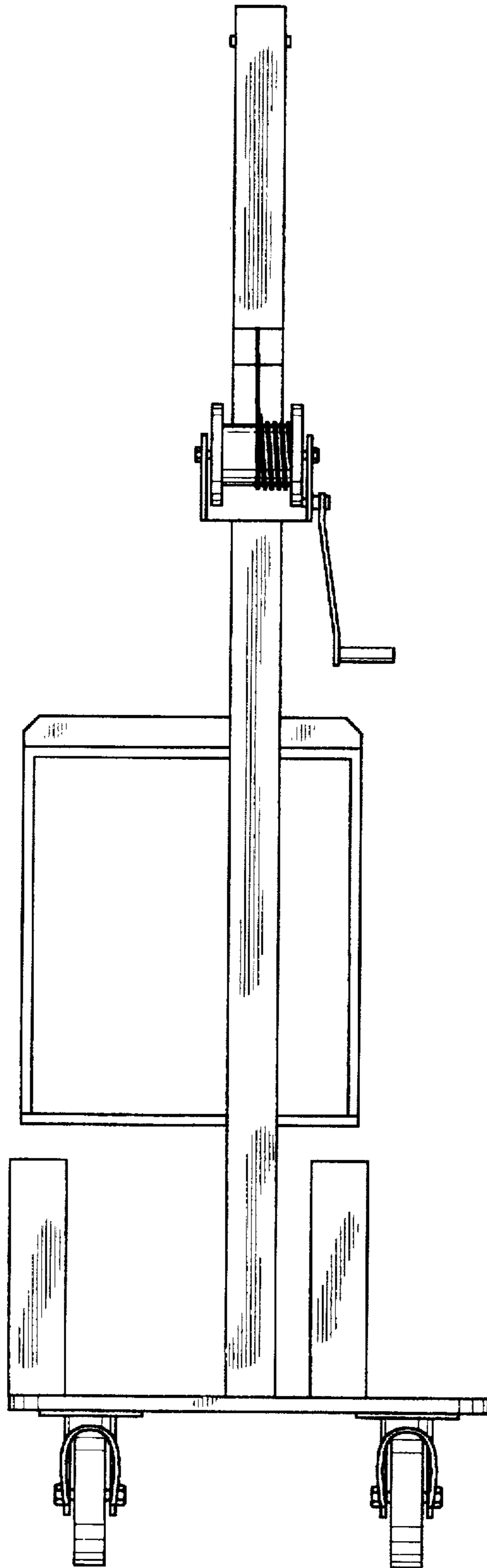

FIG. 1

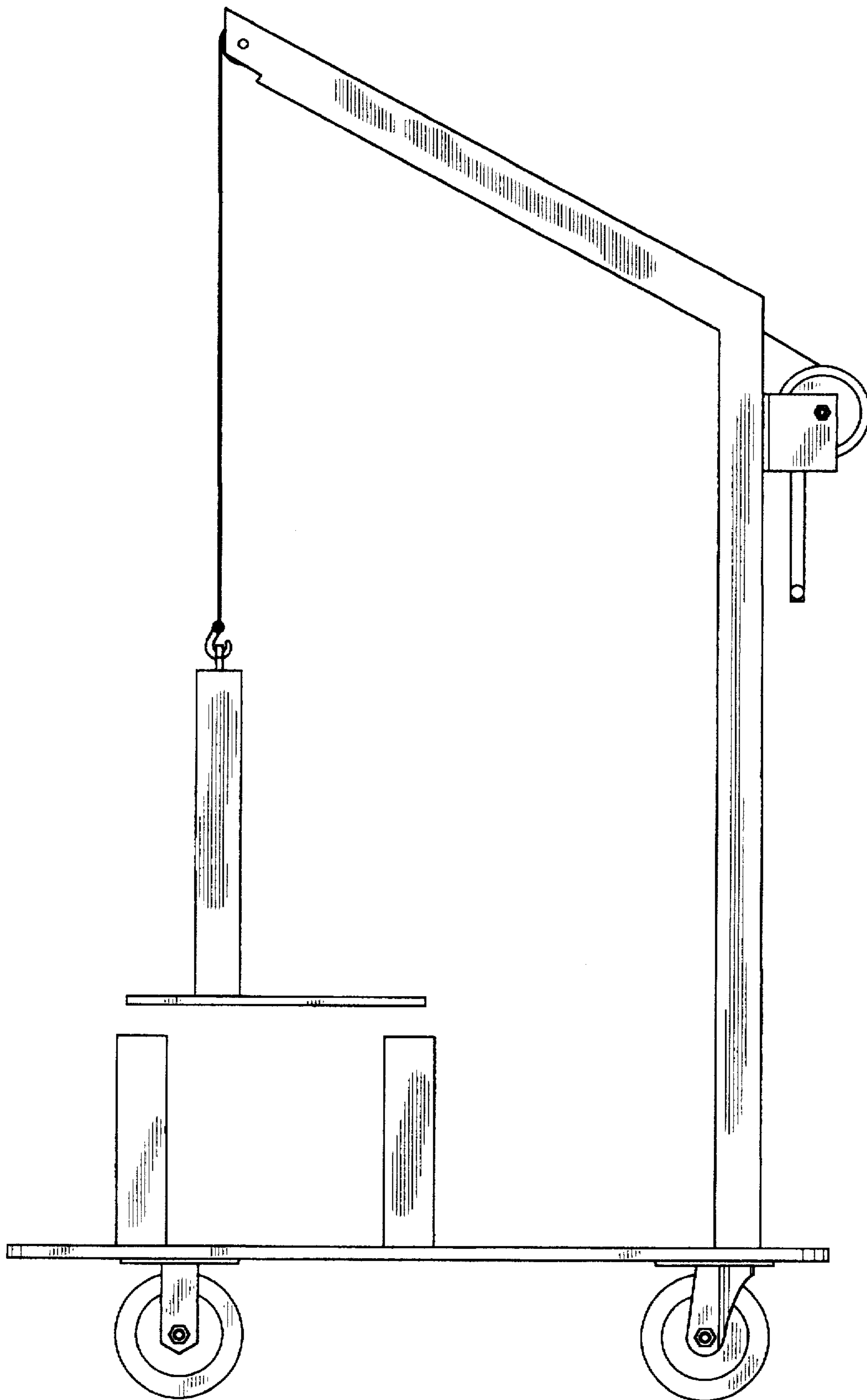

FIG. 2

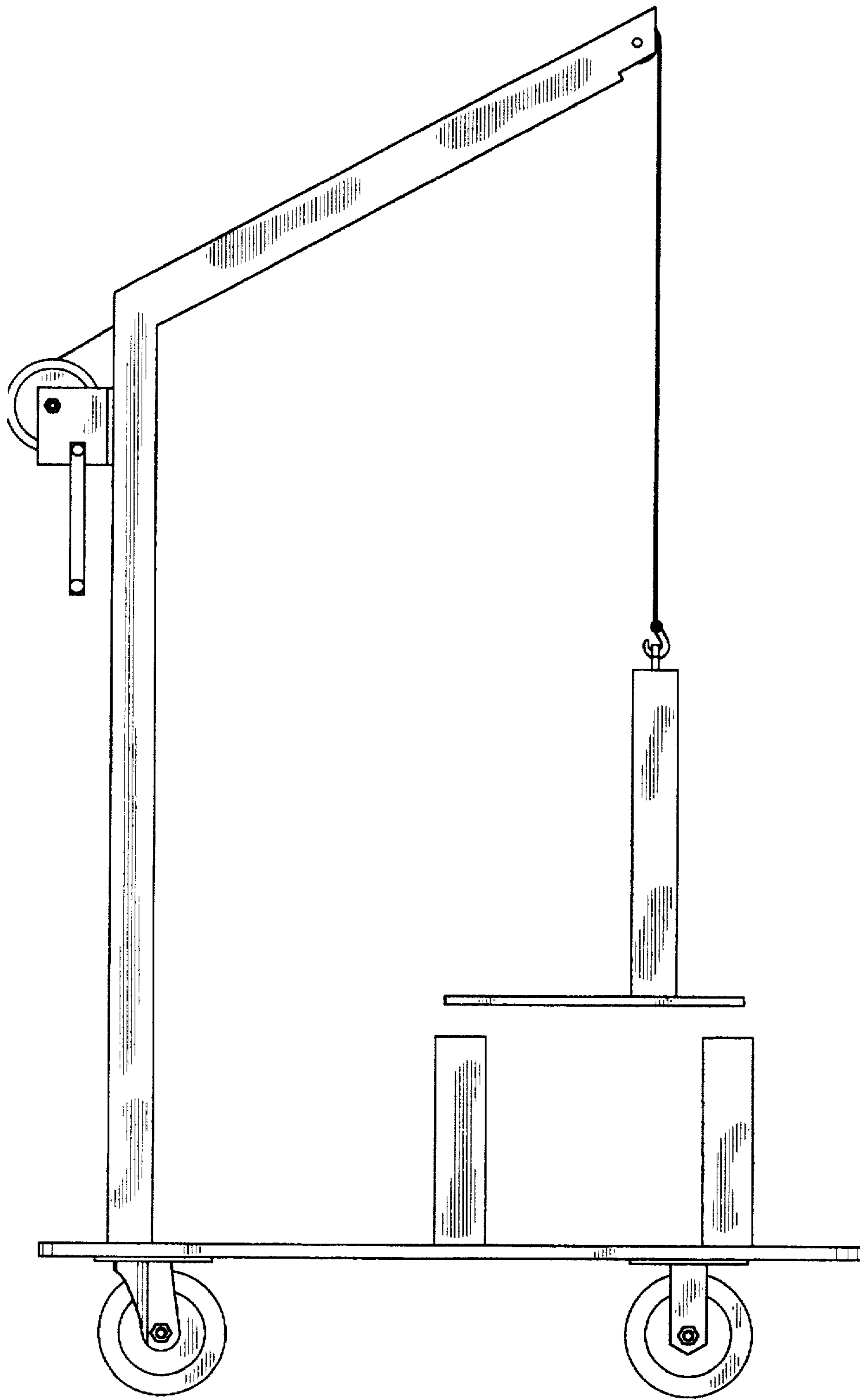

FIG. 3

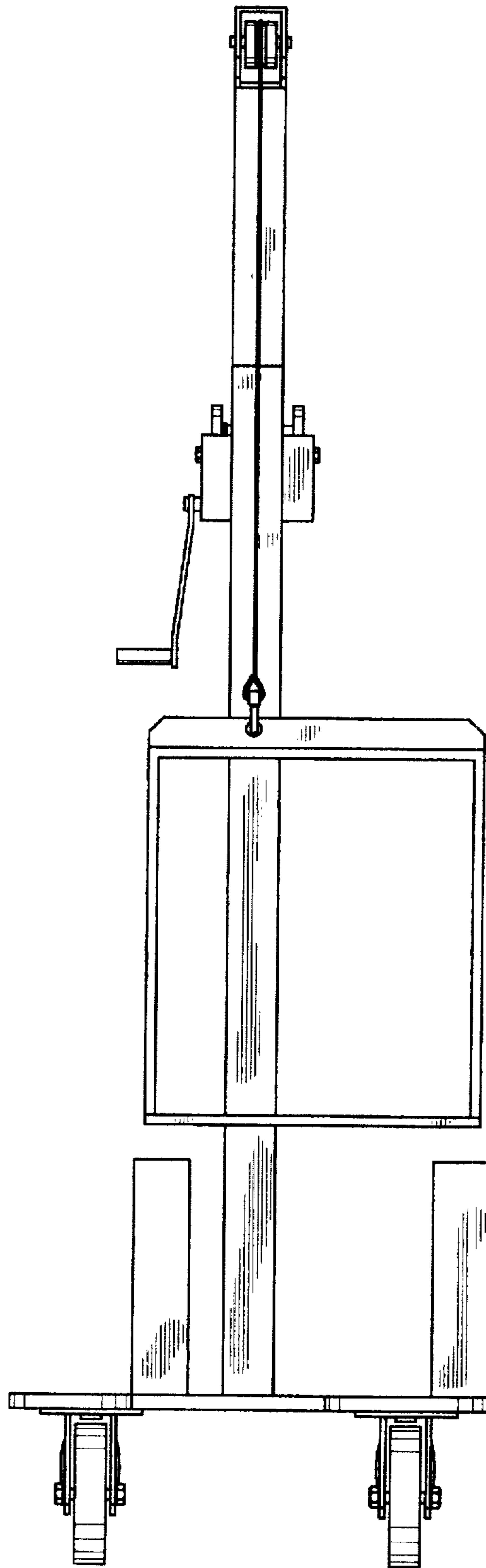

FIG. 4

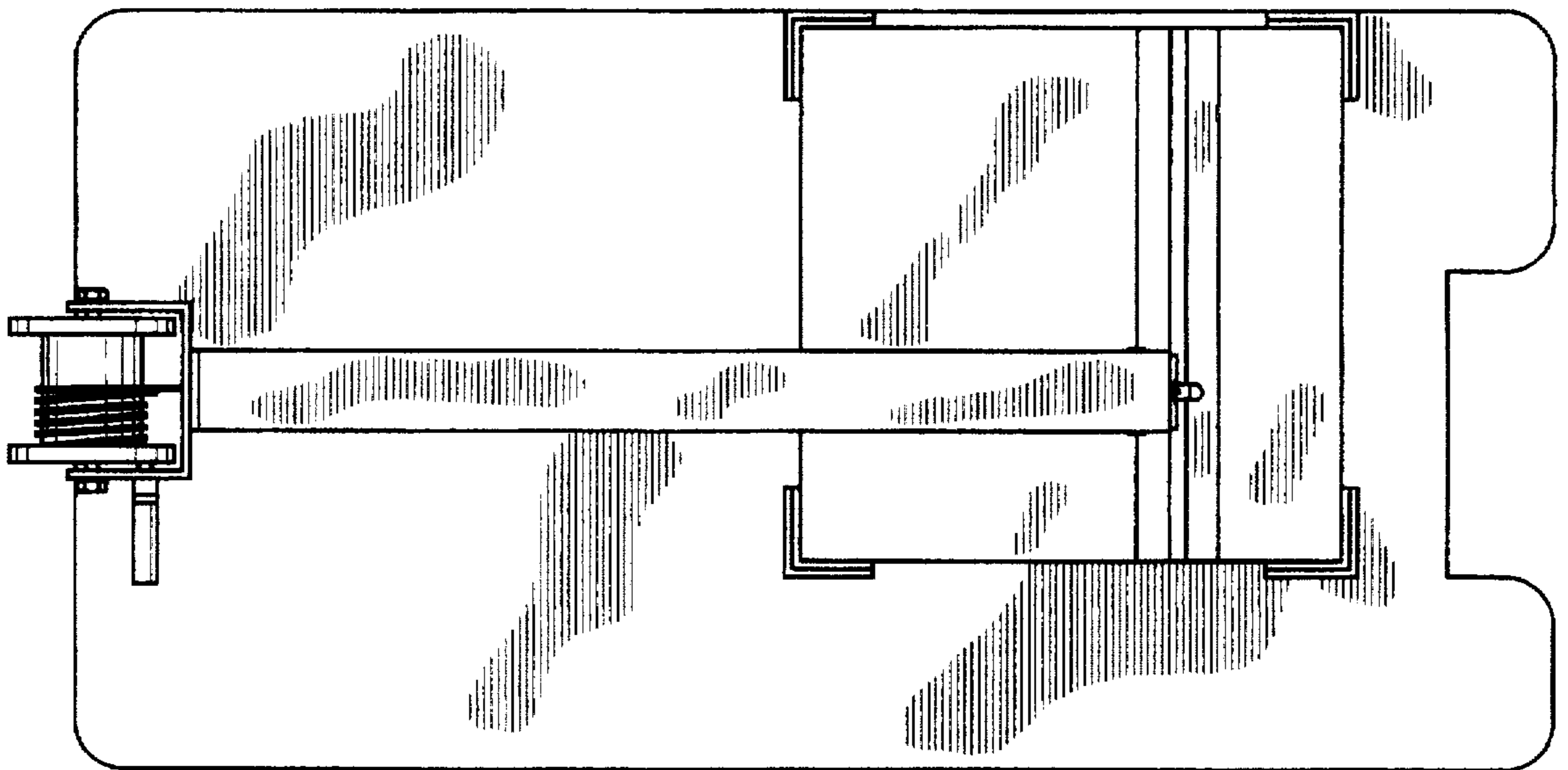

FIG. 5

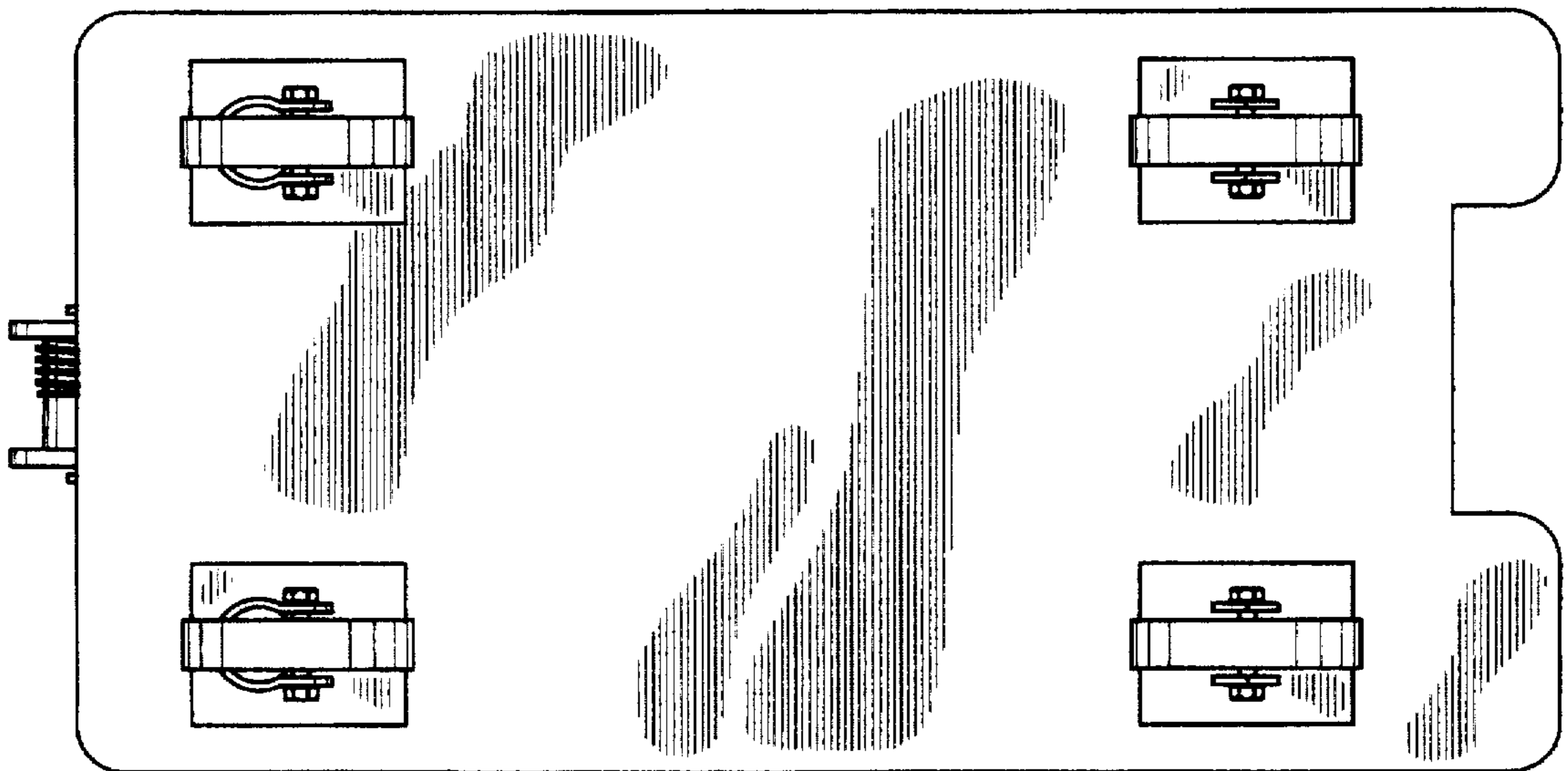

FIG. 6