



US00D396045S

United States Patent [19]

Neeley

[11] Patent Number: Des. 396,045

[45] Date of Patent: **Jul. 14, 1998

[54] INTERNAL COMBUSTION ENGINE

5,251,428 10/1993 Gay D15/16 X

[75] Inventor: Brian D. Neeley, Nix, Wis.

OTHER PUBLICATIONS

[73] Assignee: Tecumseh Products Company,
Tecumseh, Mich.

Jeg's High Performance Mail Order Catalog, p. 129-Q,
Power Package, Briggs and Stratton engine, Apr. 1993.

[**] Term: 14 Years

Primary Examiner—Sandra L. Morris
Assistant Examiner—Nanda Bonade
Attorney, Agent, or Firm—Baker & Daniels

[21] Appl. No.: 47,355

[57] CLAIM

[22] Filed: Dec. 1, 1995

The ornamental design for an internal combustion engine, as shown and described.

[51] LOC (6) Cl. 15-01

[52] U.S. Cl. D15/1; D15/17

[58] Field of Search D15/1-5, 14-17;
123/41.7, 198 E

DESCRIPTION

[56] References Cited

U.S. PATENT DOCUMENTS

D. 198,043	4/1964	Stevens	D15/17
D. 352,043	11/1994	Davies, III	D15/17
4,233,043	11/1980	Catterson	123/198 E X
5,197,426	3/1993	Frangesch et al.	123/198 E
5,199,389	4/1993	Wold et al.	123/41.07

FIG. 1 is a front perspective view of an internal combustion engine showing my new design;
FIG. 2 is a front elevational view thereof;
FIG. 3 is a rear elevational view thereof;
FIG. 4 is a left side elevational view thereof;
FIG. 5 is a right side elevational view thereof;
FIG. 6 is a top plan view thereof; and,
FIG. 7 is a bottom plan view thereof.

1 Claim, 4 Drawing Sheets

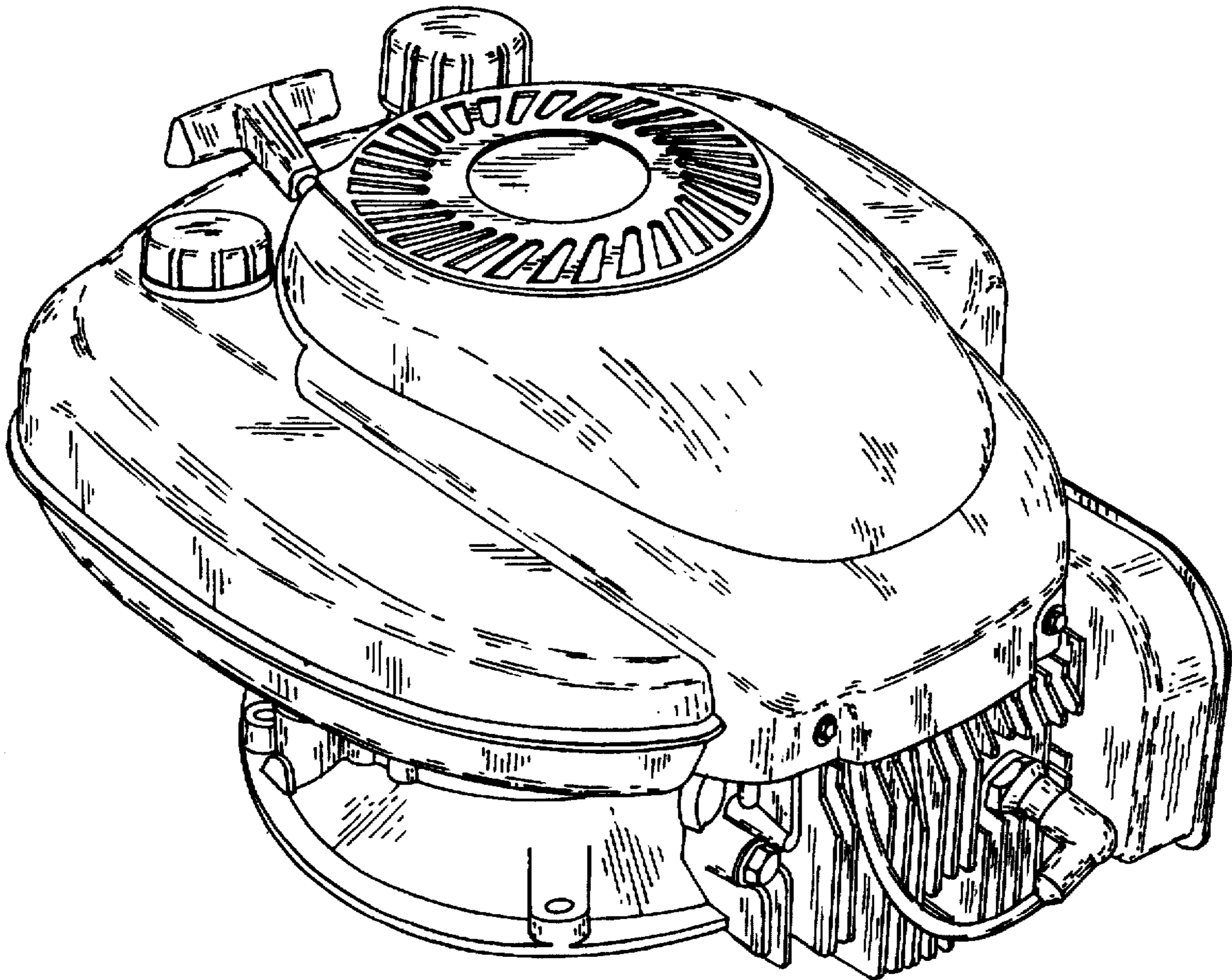

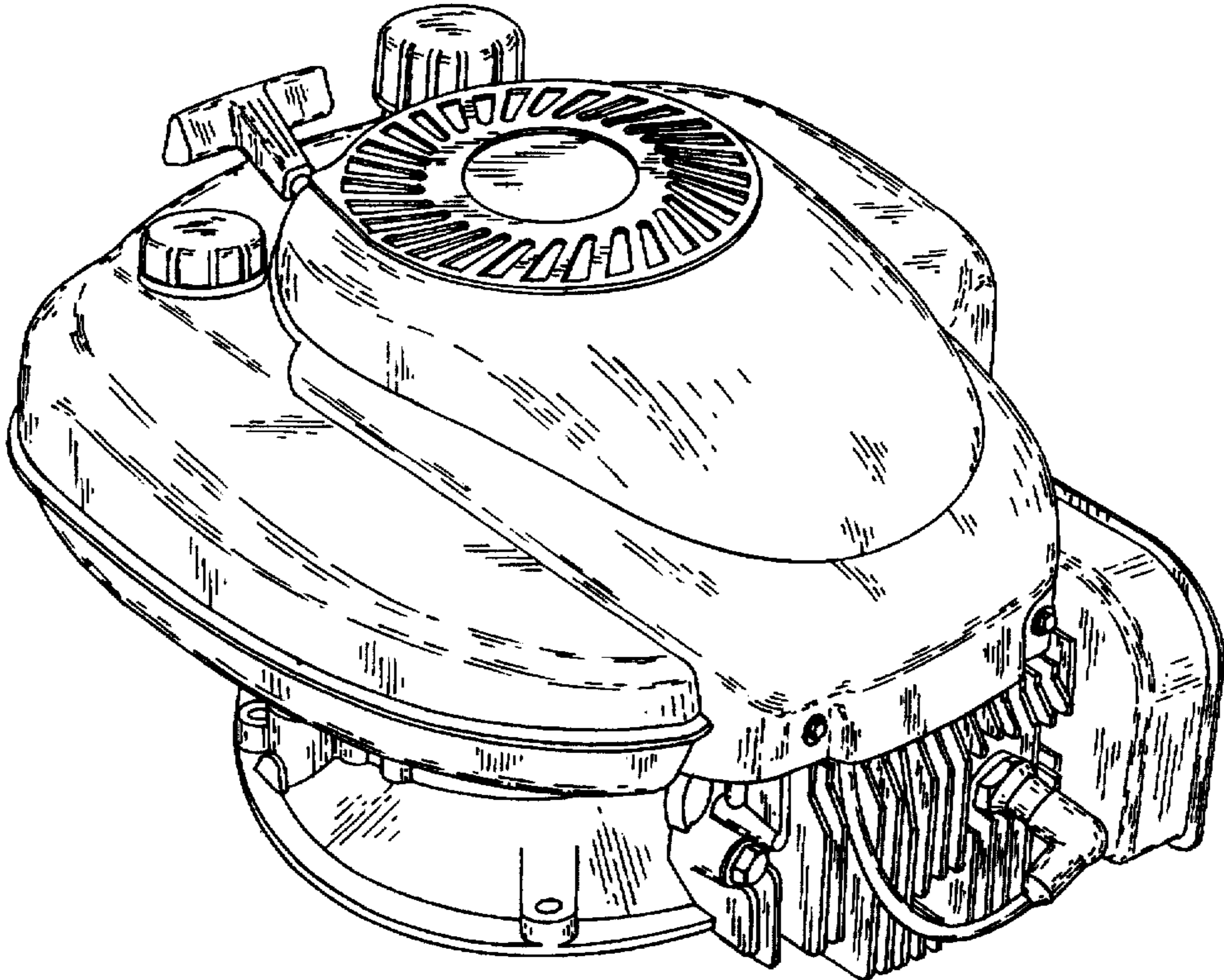

FIG. 1

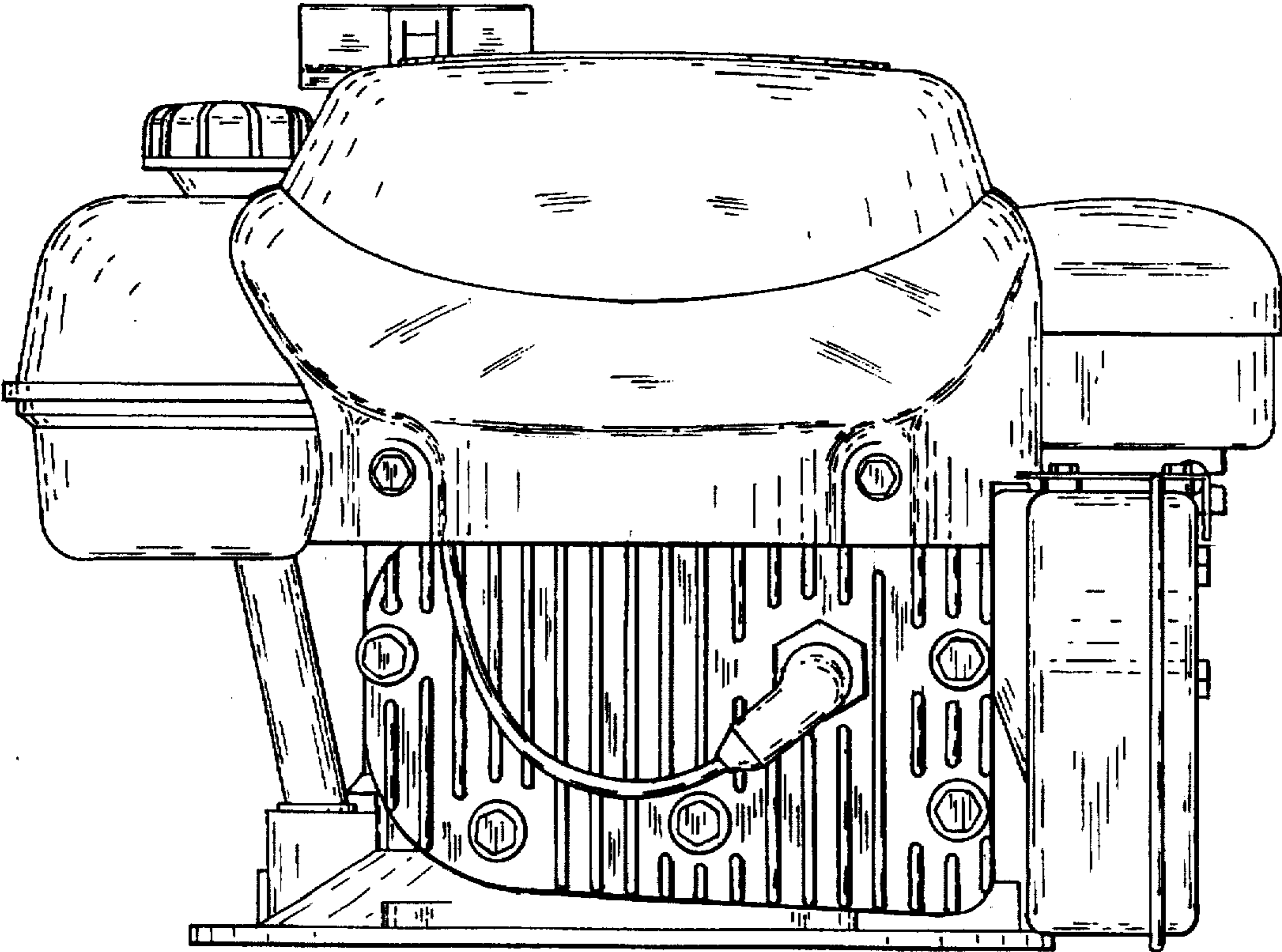

FIG. 2

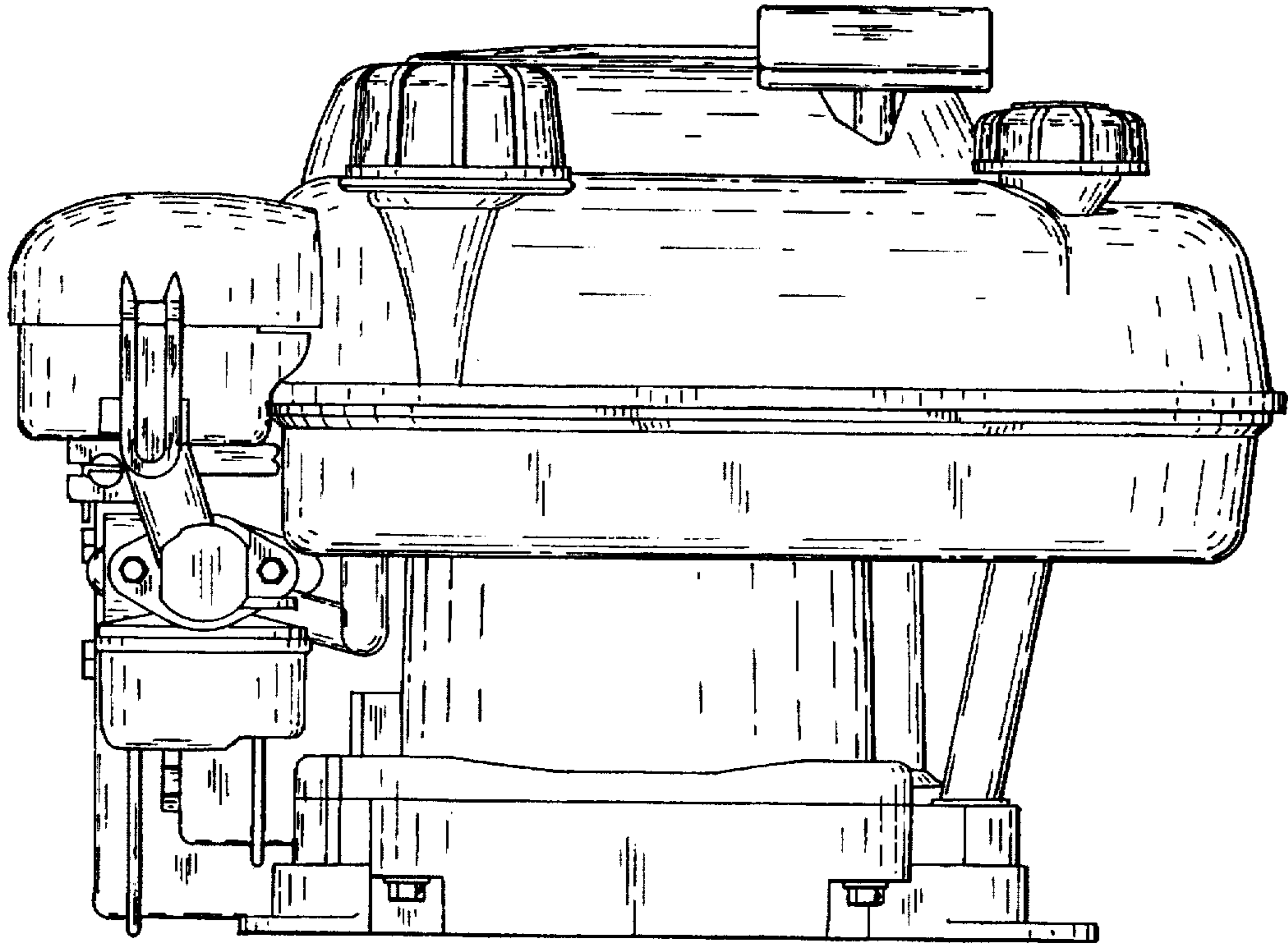

FIG. 3

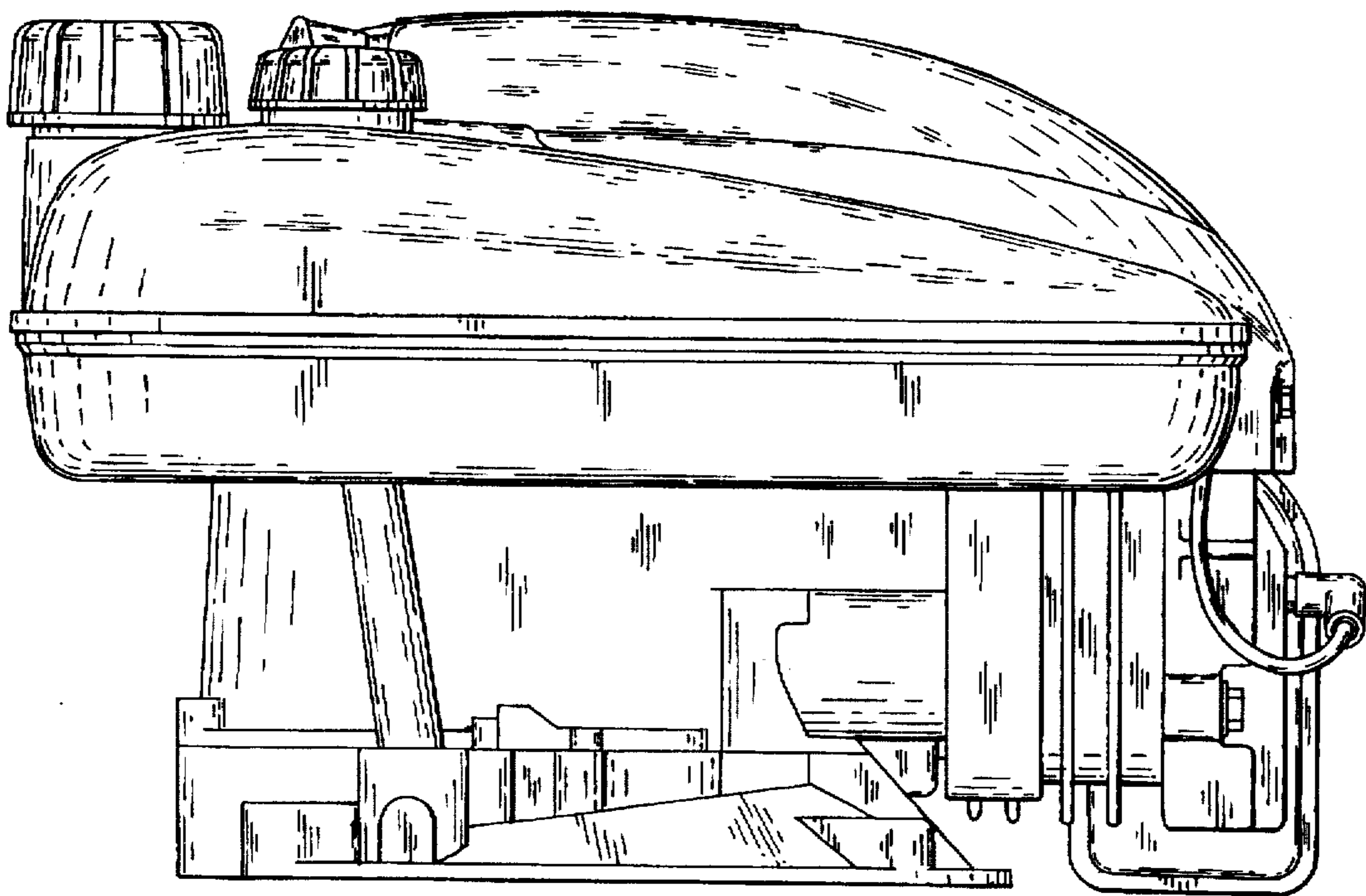

FIG. 4

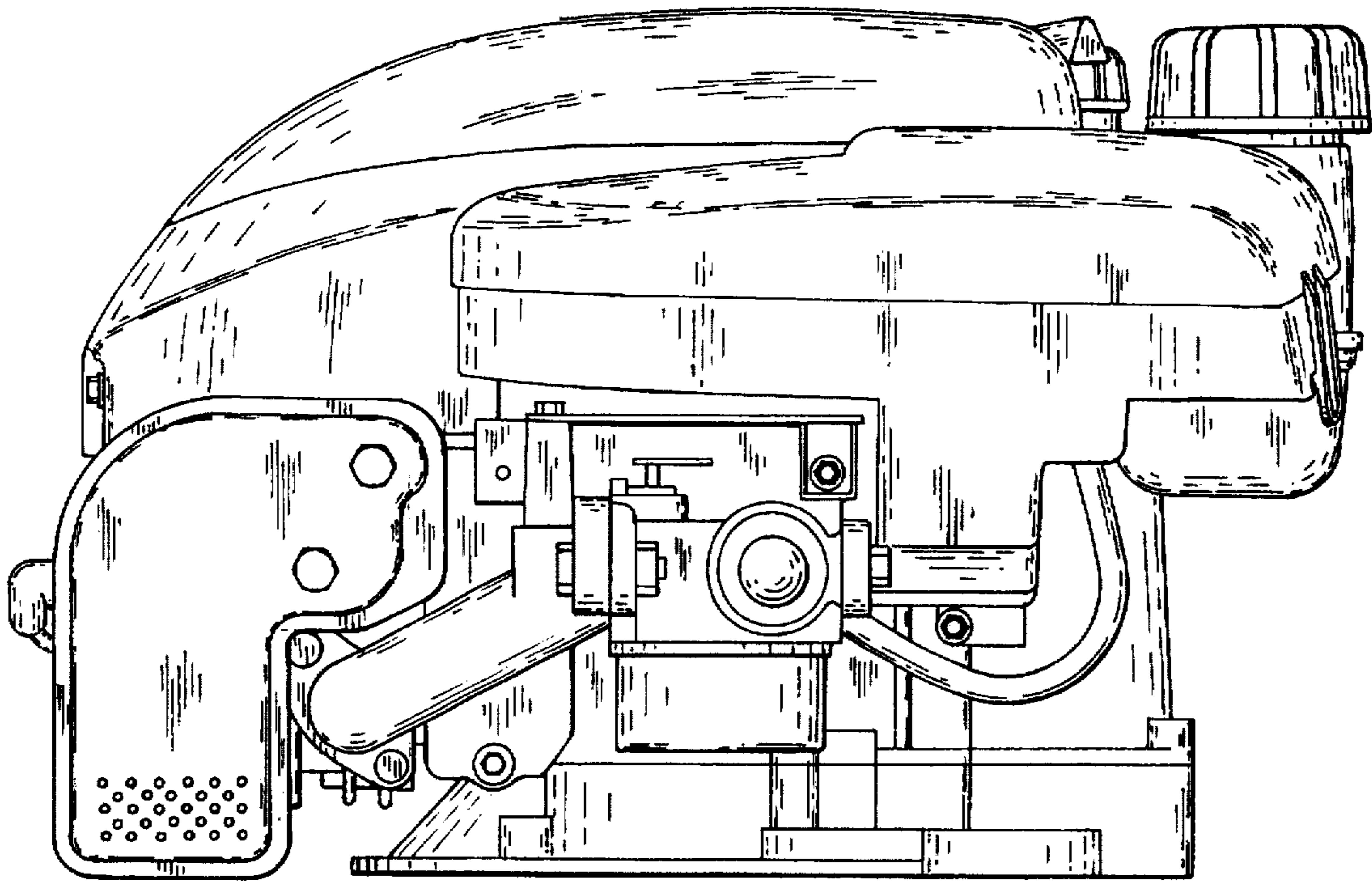

FIG. 5

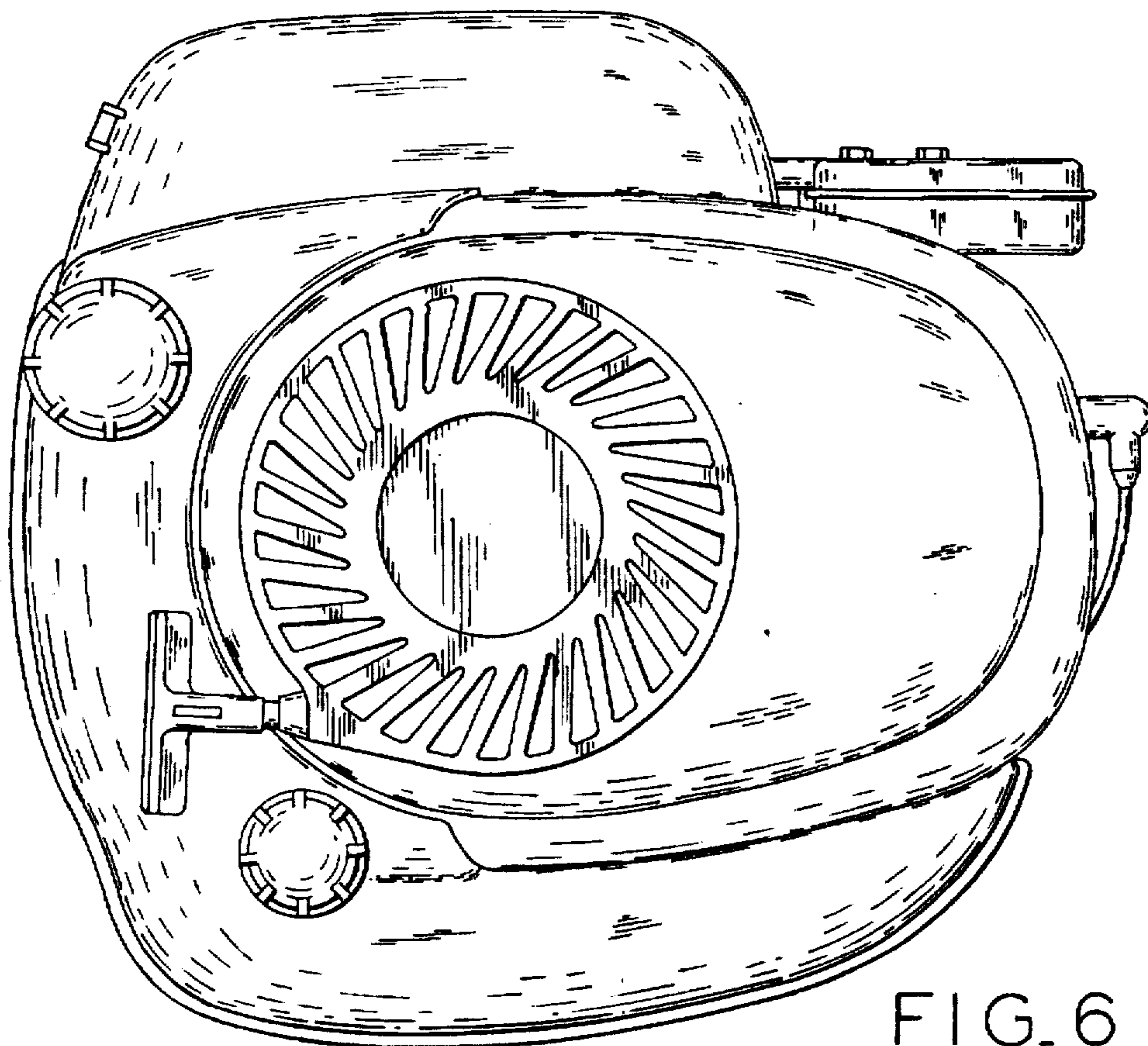

FIG. 6

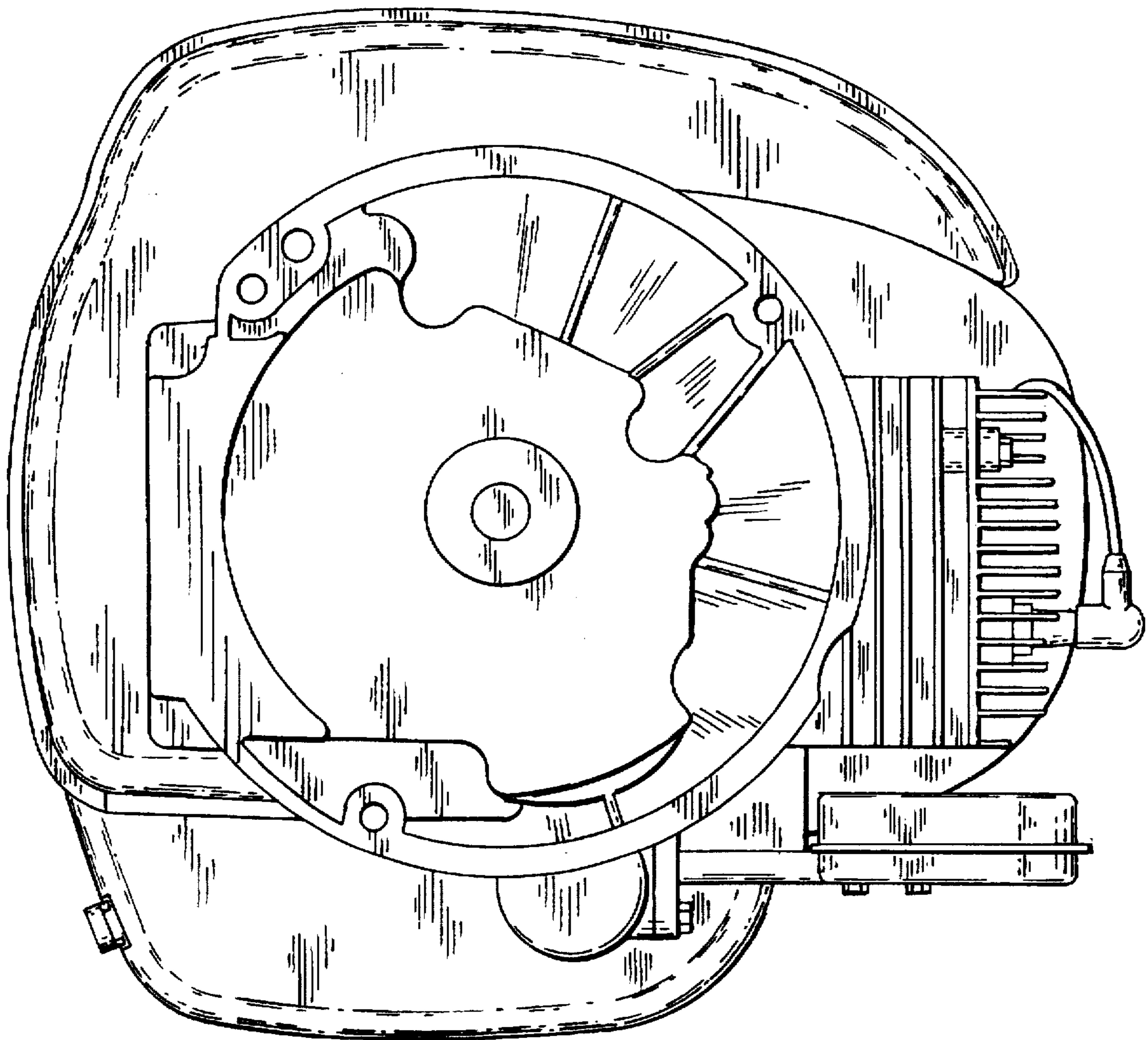

FIG. 7