



US00D395683S

United States Patent [19]

Chiappetta

[11] Patent Number: **Des. 395,683**

[45] Date of Patent: ****Jun. 30, 1998**

[54] **COMBINED TOY HELICOPTER AND AUTOMOBILE**

[75] Inventor: **Frank Richard Chiappetta**, Berwyn, Pa.

[73] Assignee: **Fran-Rich-Chi Associates**, Berwyn, Pa.

[**] Term: **14 Years**

[21] Appl. No.: **52,908**

[22] Filed: **Apr. 8, 1996**

Related U.S. Application Data

[63] Continuation-in-part of Ser. No. 118,966, Sep. 9, 1993, Pat. No. 5,505,407.

[51] **LOC (6) Cl.** **21-01**

[52] **U.S. Cl.** **D21/128**

[58] **Field of Search** D21/71, 76, 77, D21/78, 79, 82, 87, 90, 134, 128, 136, 137; D12/87, 91; 446/37, 163, 420, 462, 456, 465; 280/828

[56] References Cited

U.S. PATENT DOCUMENTS

- D. 205,326 7/1966 Postelson-Apostolescu D12/91
- D. 233,359 10/1974 Krumholz D21/134

- D. 365,311 12/1995 Mosekich, et al. D21/76
- 3,082,977 3/1963 Arlin 446/37
- 4,161,843 7/1979 Hui 446/37
- 5,127,658 7/1992 Openiano 446/456
- 5,441,289 8/1995 Spielberg D21/136

Primary Examiner—Raphael Barkai
Attorney, Agent, or Firm—William H. Meise

[57] CLAIM

The ornamental design for a combined toy helicopter and automobile, as shown and described.

DESCRIPTION

FIG. 1 is a right side perspective view of a combined toy helicopter and automobile showing my new design; FIG. 2 is a left side perspective view thereof; FIG. 3 is right side perspective view of a modified embodiment of the design shown in FIGS. 1 and 2; FIG. 4 is left side perspective view thereof; FIG. 5 is right side perspective view of the design shown in FIG. 1 with the environmental structure omitted for clarity; FIG. 6 is a left side perspective view thereof; and, FIG. 7 is a rear elevational view of the design shown in FIG. 1.

The broken lines shown in FIGS. 1-4 is for illustrative purposes only and forms no part of the claimed design.

1 Claim, 7 Drawing Sheets

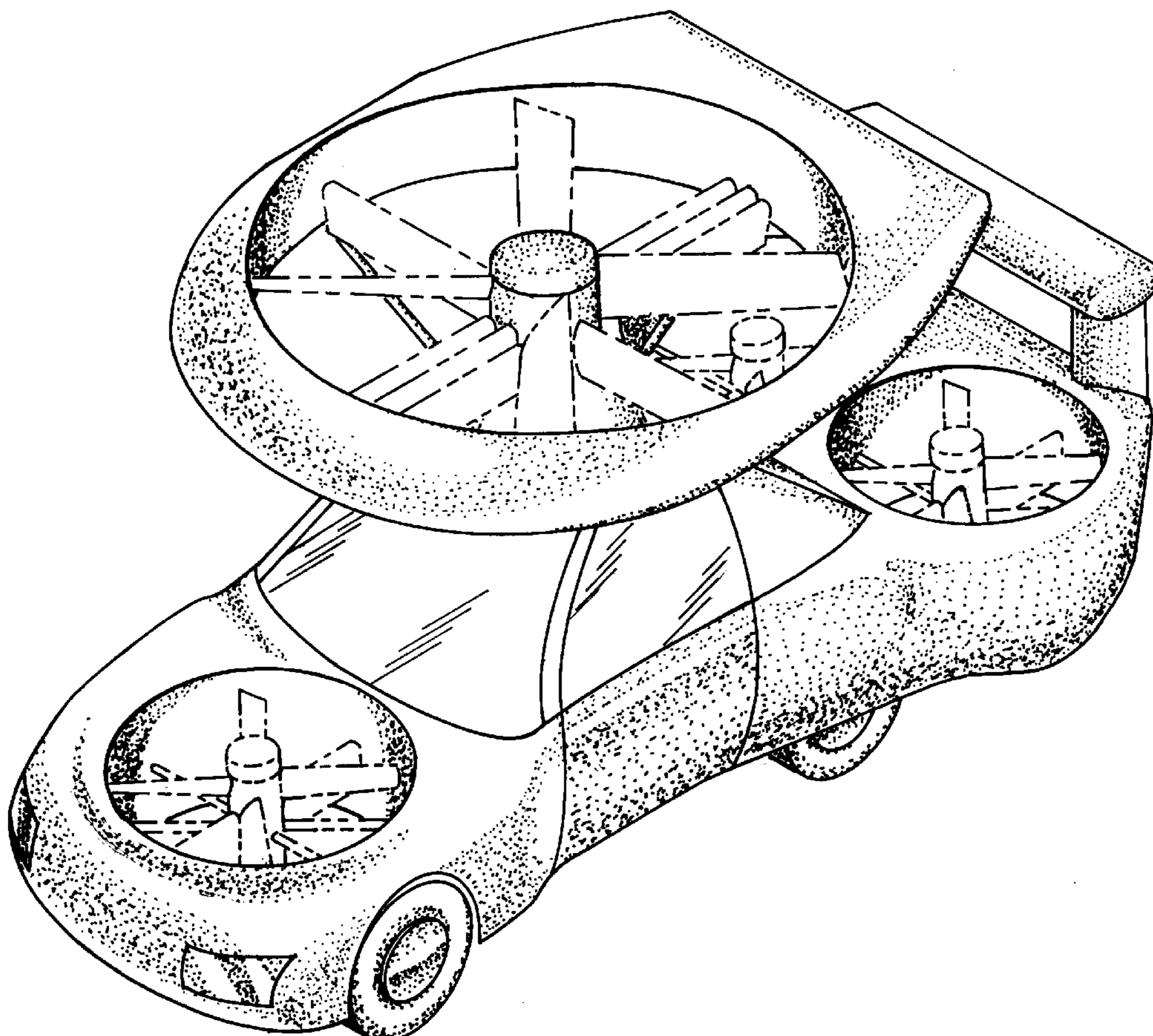

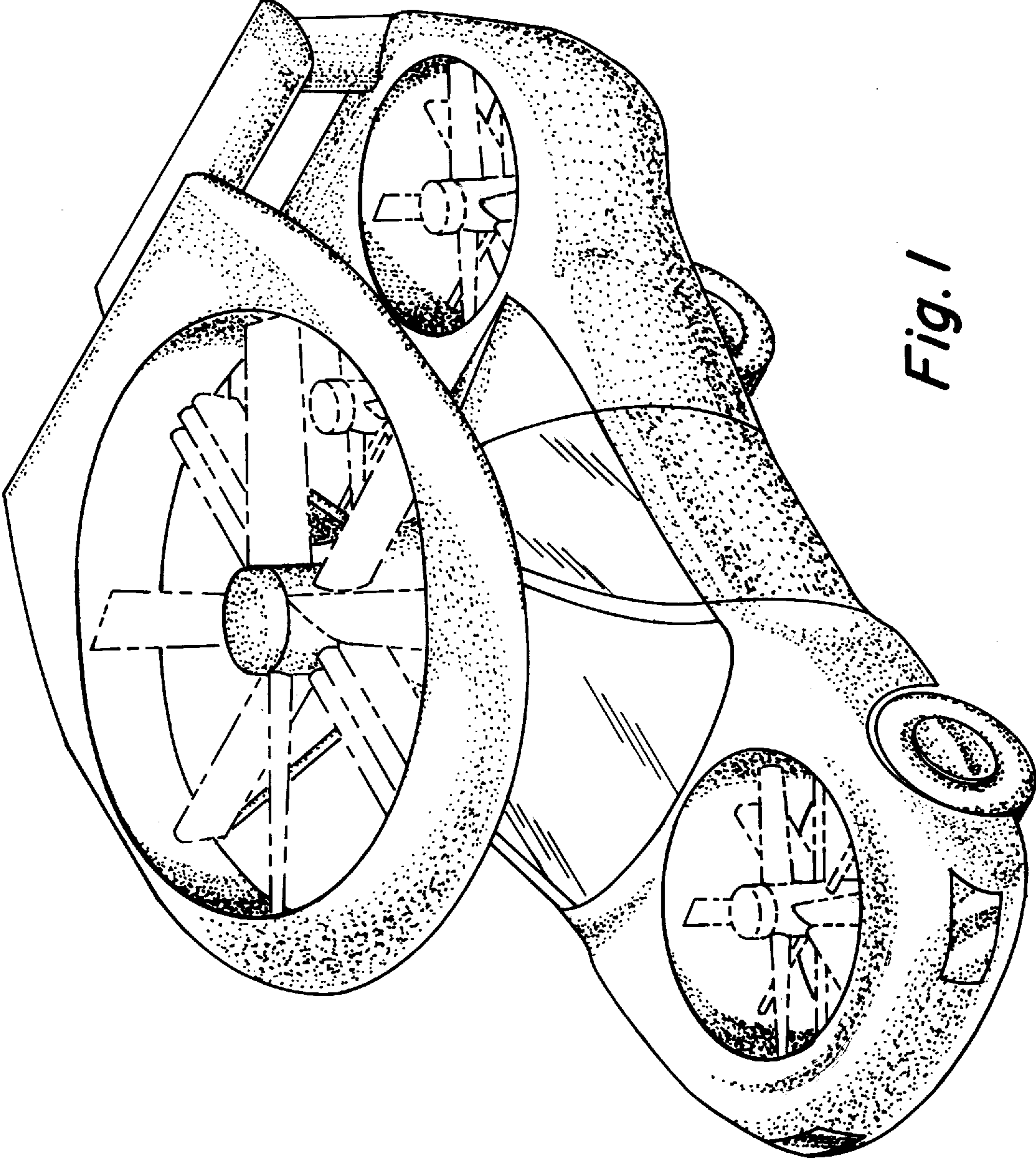

Fig. 1

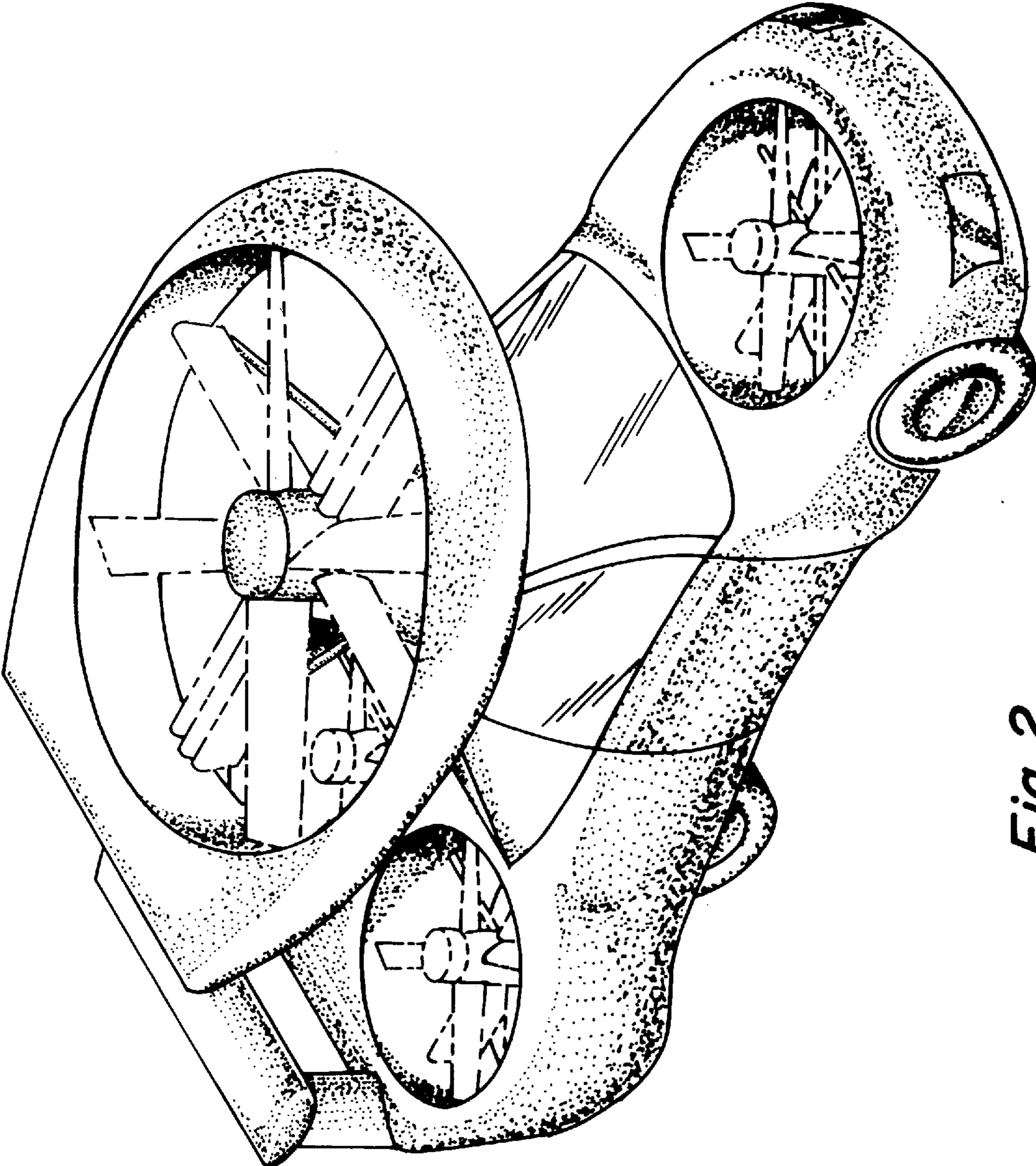

Fig. 2

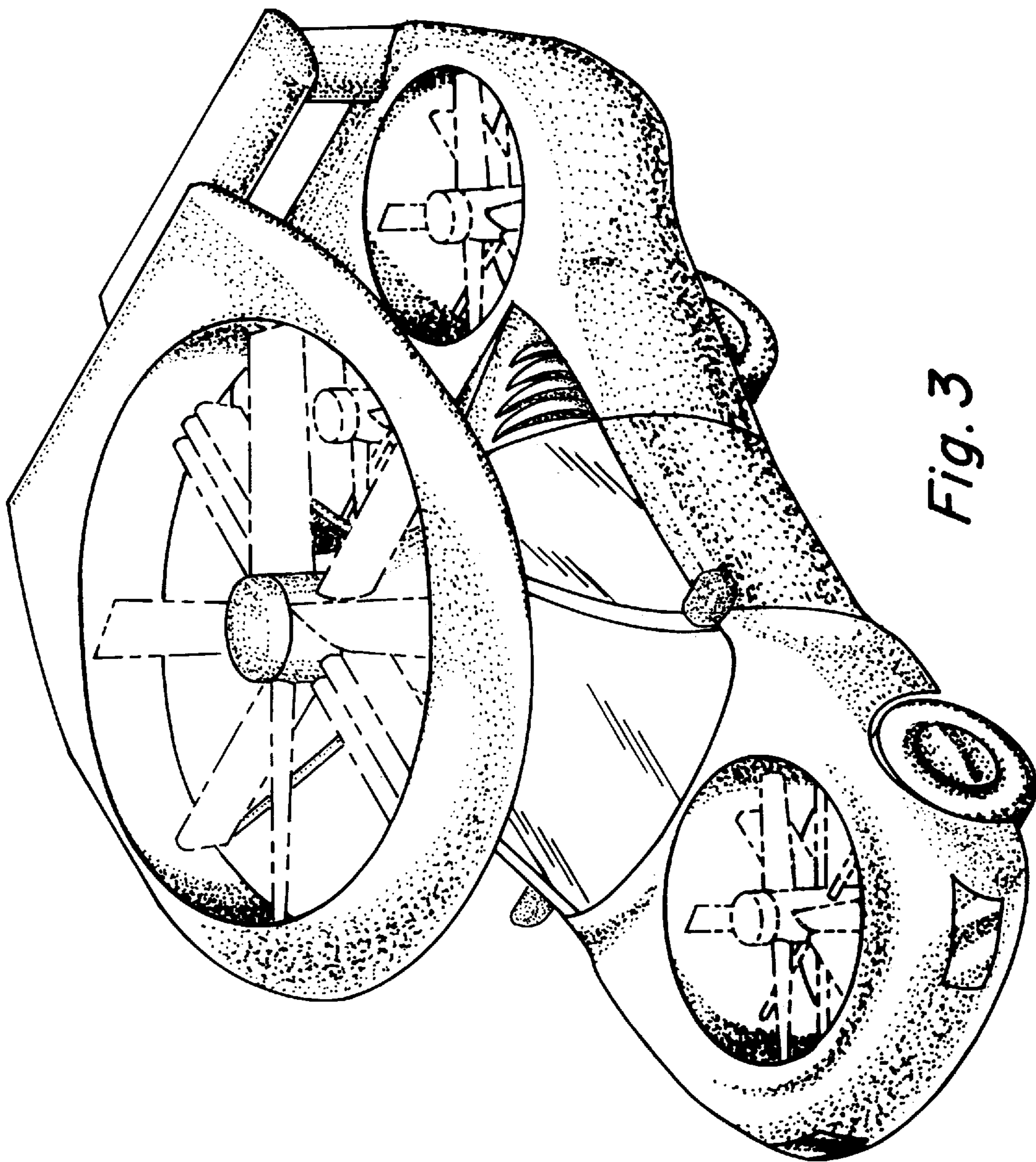

Fig. 3

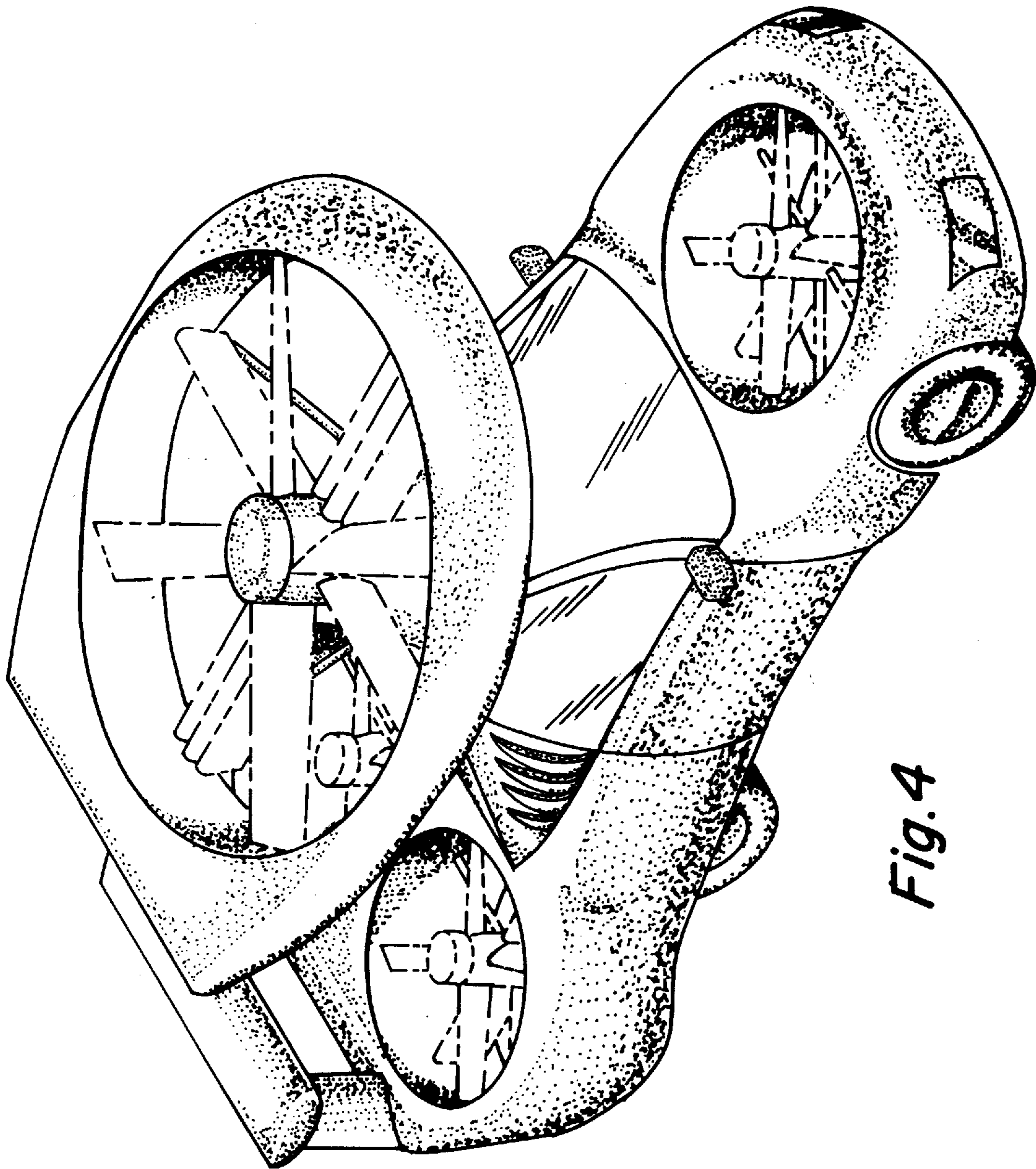
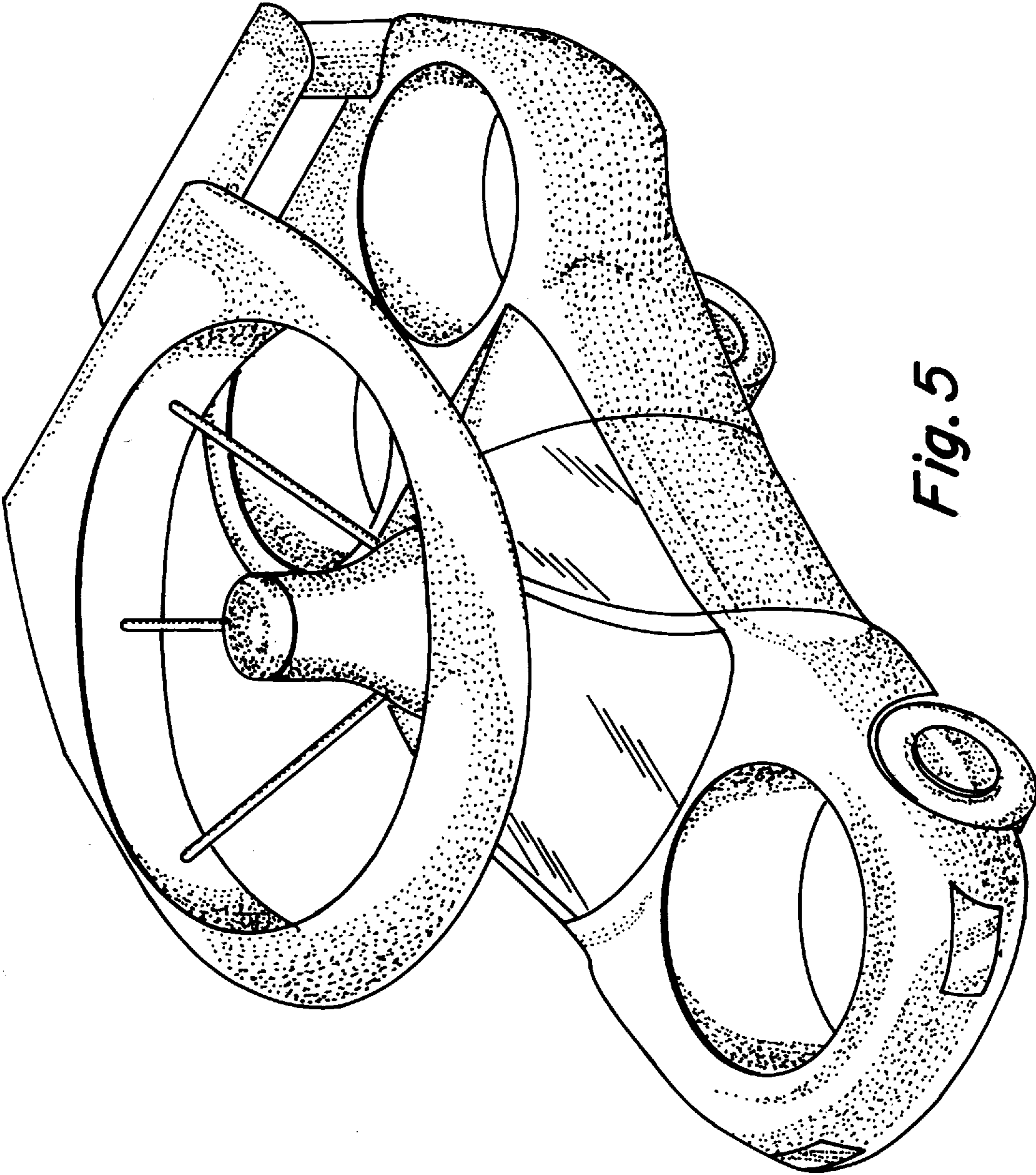

Fig. 4



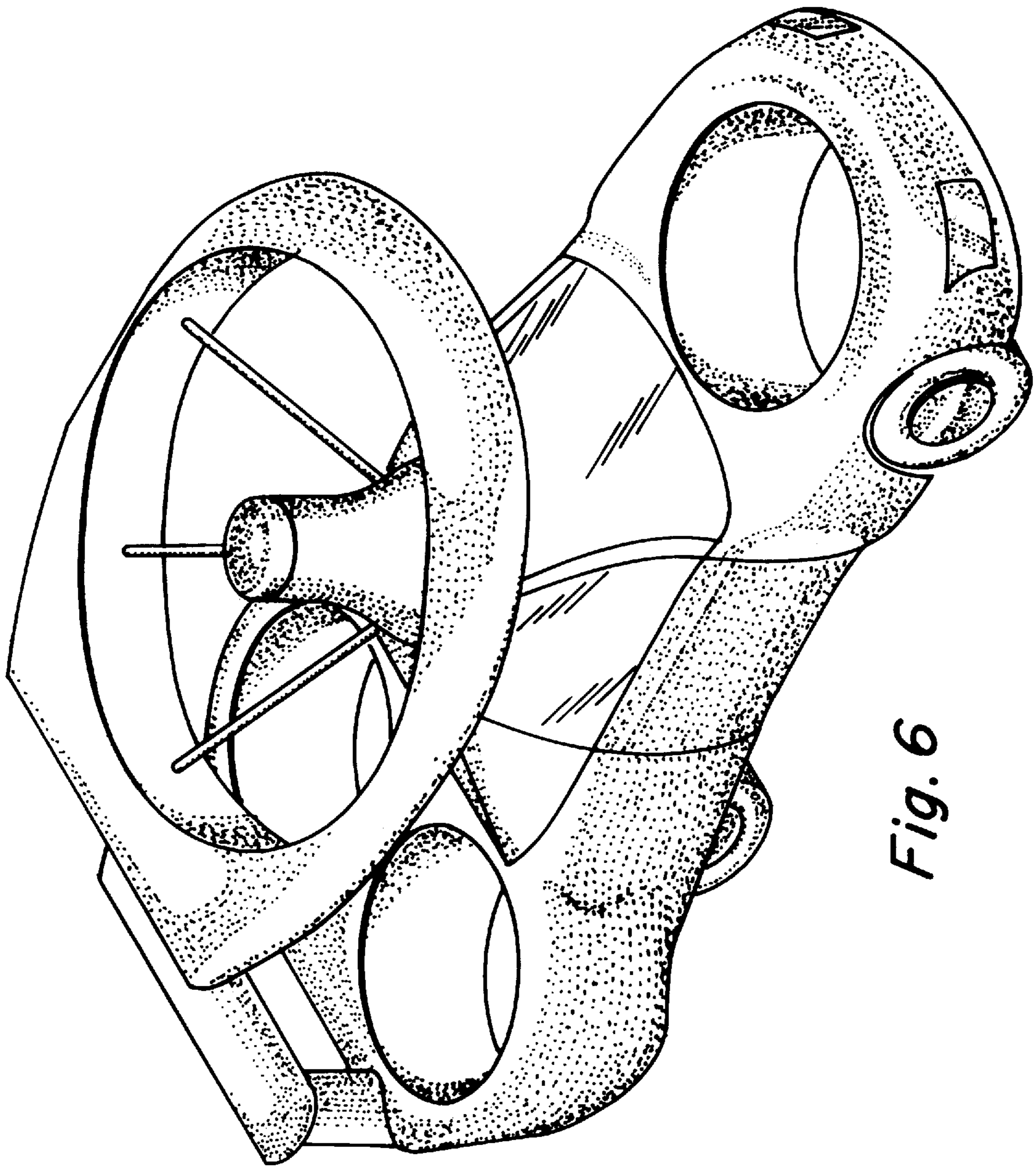

Fig. 6

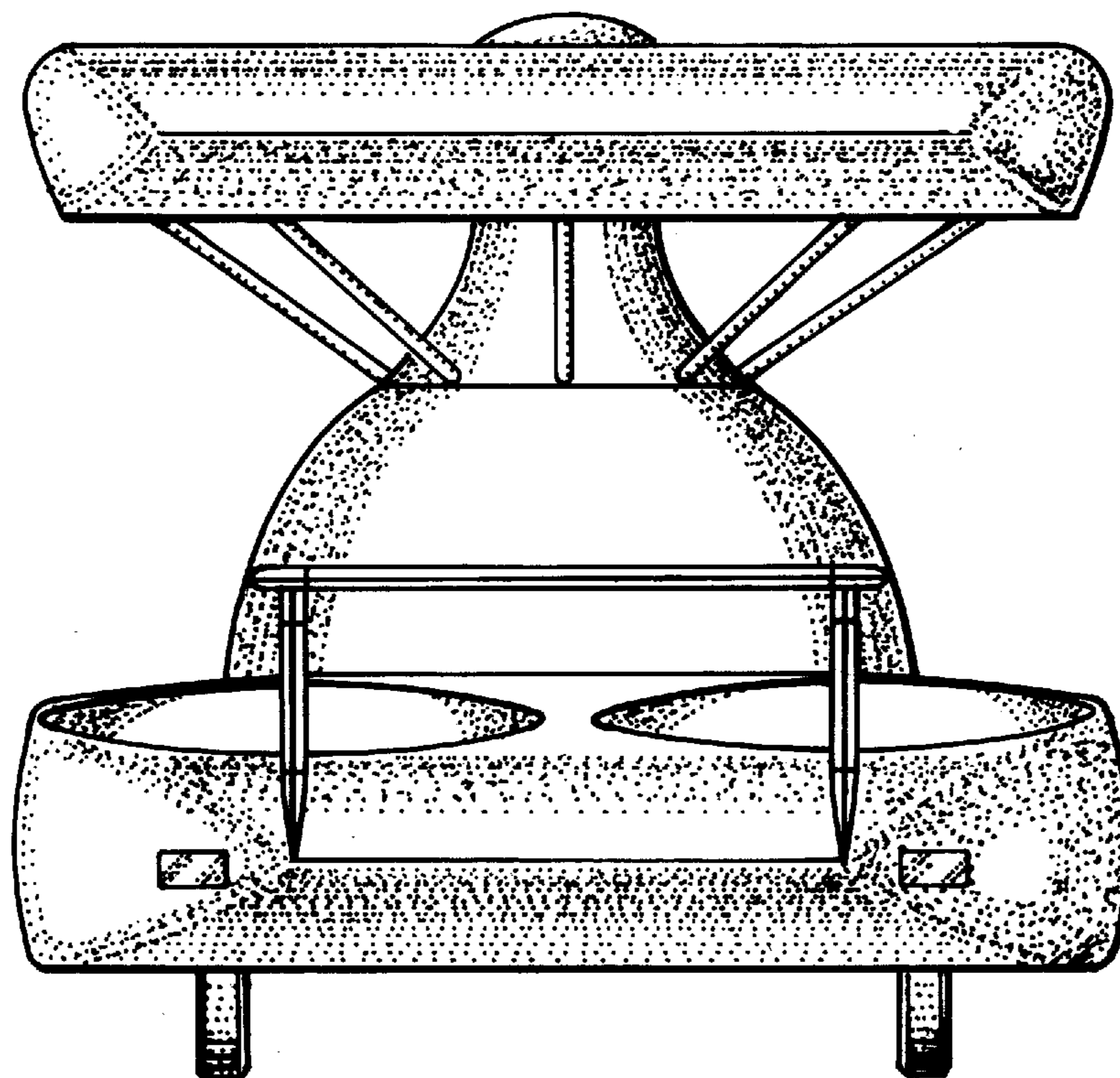

Fig. 7