



US00D395421S

# United States Patent [19]

Gable et al.

[11] Patent Number: Des. 395,421

[45] Date of Patent: \*\*Jun. 23, 1998

[54] **COMBINED CARRIER AND SEAT COVER FOR A BICYCLE**

[75] Inventors: **Jack C. Gable; Kenneth C. Smith; Nicholas W. Markin**, all of Kelowna, Canada

[73] Assignee: **Okanagan Bike Ventures Ltd.**, Kelowna, Canada

[\*\*] Term: **14 Years**

[21] Appl. No.: **64,842**

[22] Filed: **Jan. 10, 1997**

[51] **LOC (6) Cl.** ..... **12-16**

[52] **U.S. Cl.** ..... **D12/407**

[58] **Field of Search** ..... D12/186, 407; 280/152.1-152.3, 166, 851, 158.1; 224/413-416

### [56] **References Cited**

#### U.S. PATENT DOCUMENTS

D. 185,323	5/1959	Schreckenyoost	.....	D12/407
D. 311,510	10/1990	Royce	.....	D12/707
D. 320,590	10/1991	Dunn	.....	D12/186
D. 325,367	4/1992	Cottel	.....	D12/186
585,474	6/1897	Heaton	.....	224/413
1,040,192	10/1912	Hall	.....	224/416
3,901,534	8/1975	Popken	.....	224/415
4,038,935	8/1977	Margiloff	.....	116/35
4,410,116	10/1983	Matei	.....	224/416
4,948,020	8/1990	Smith	.....	224/416
5,112,071	5/1992	Jones	.....	D12/186 X
5,121,935	6/1992	Mathieu et al.	.....	280/152.3
5,135,143	8/1992	Naughton	.....	224/416

#### FOREIGN PATENT DOCUMENTS

38706	4/1928	Denmark	.....	224/415
-------	--------	---------	-------	---------

53747	10/1937	Denmark	.....	224/415
392521	11/1908	France	.....	224/416
470354	9/1914	France	.....	224/416
576679	5/1933	Germany	.....	224/415
412743	2/1946	Italy	.....	224/413
33626	10/1912	Switzerland	.....	224/416
16112	of 1897	United Kingdom	.....	224/413
20590	of 1904	United Kingdom	.....	224/416
15030	of 1914	United Kingdom	.....	224/416
348409	5/1931	United Kingdom	.....	224/413
415558	8/1934	United Kingdom	.....	224/413

### OTHER PUBLICATIONS

Performance Bicycle, pp. 19 & 57, the Headland Utility X Rack, the Topeak MTB Bike Fender and Zebal Bike Fender, Midsummer 1995.

*Primary Examiner*—Melody N. Brown  
*Attorney, Agent, or Firm*—Antony C. Edwards

### [57] **CLAIM**

The ornamental design for a combined carrier and seat cover for a bicycle.

### **DESCRIPTION**

FIG. 1 is a top plan view of the combined carrier and seat cover for a bicycle of the present design in a closed position; FIG. 2 is a right side elevation view of the design of FIG. 1, the left side elevation view being identical; FIG. 3 is a bottom plan view of the design of FIG. 1; FIG. 4 is a front elevation view of the design of FIG. 1; FIG. 5 is a rear elevation view of the design of FIG. 1; FIG. 6 is a perspective view of the design of FIG. 1; FIG. 7 is a right side elevation view of the combined carrier and seat cover for a bicycle of the present design in an open position. FIG. 8 is a perspective view of the design of FIG. 7.

**1 Claim, 5 Drawing Sheets**

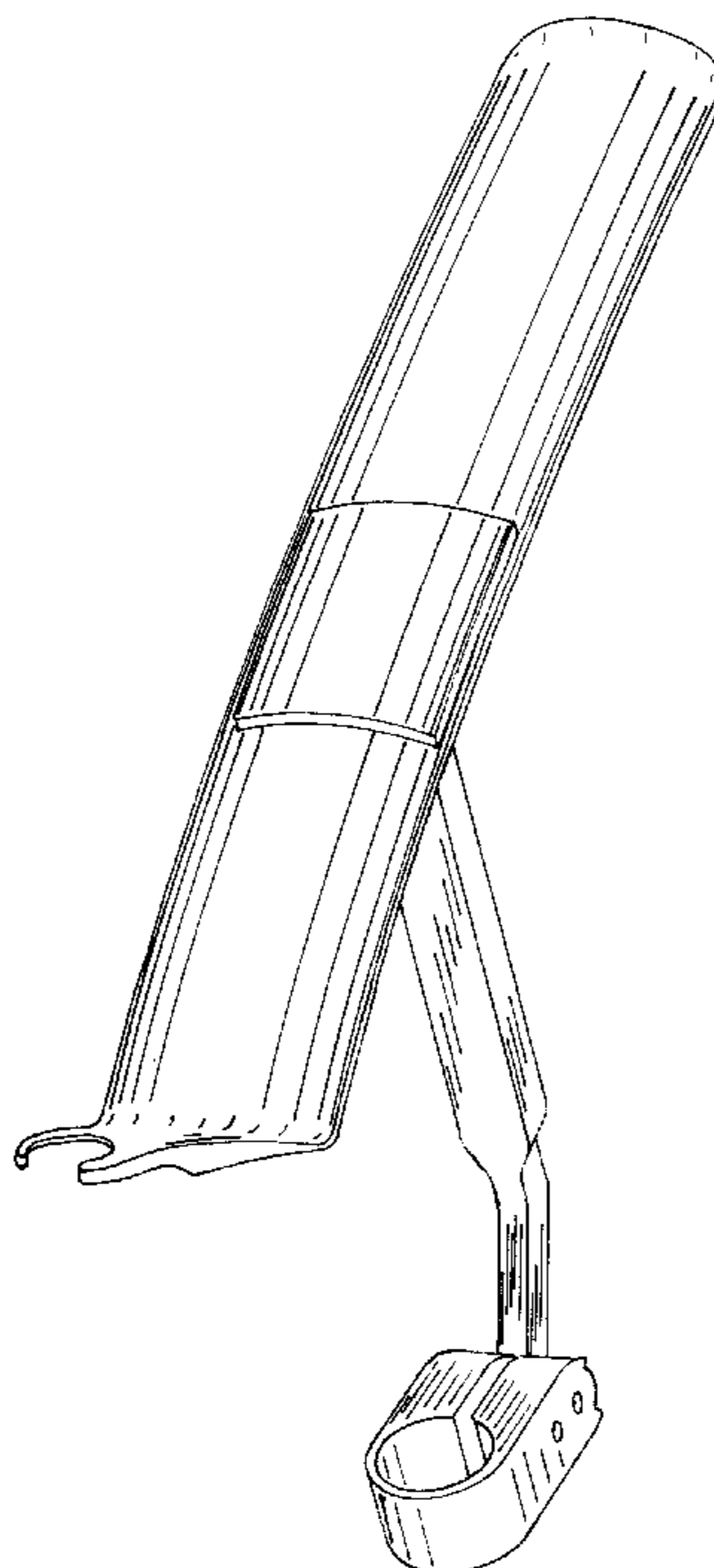

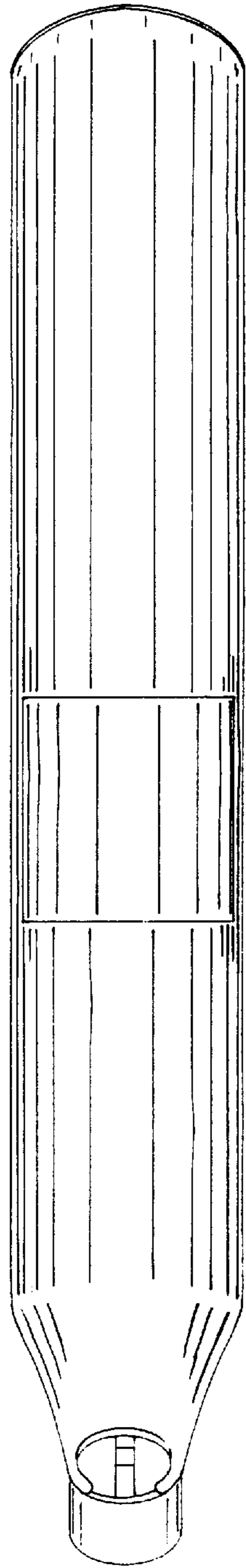

FIG. 1

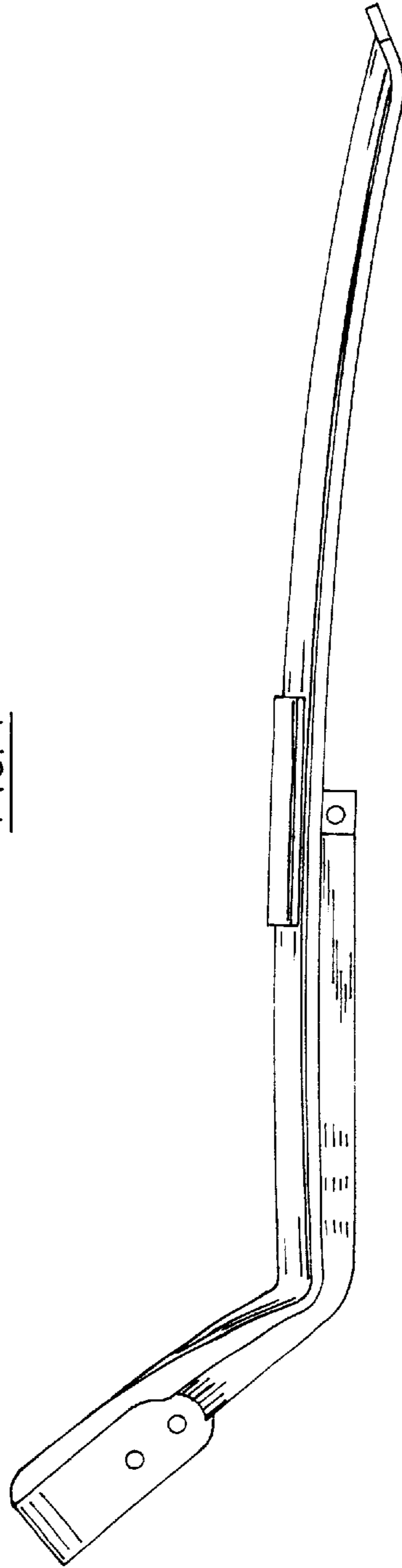

FIG. 2

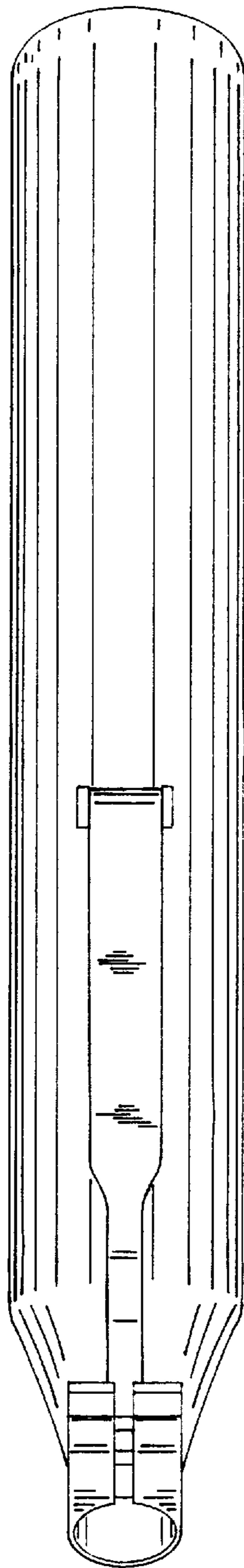

FIG. 3

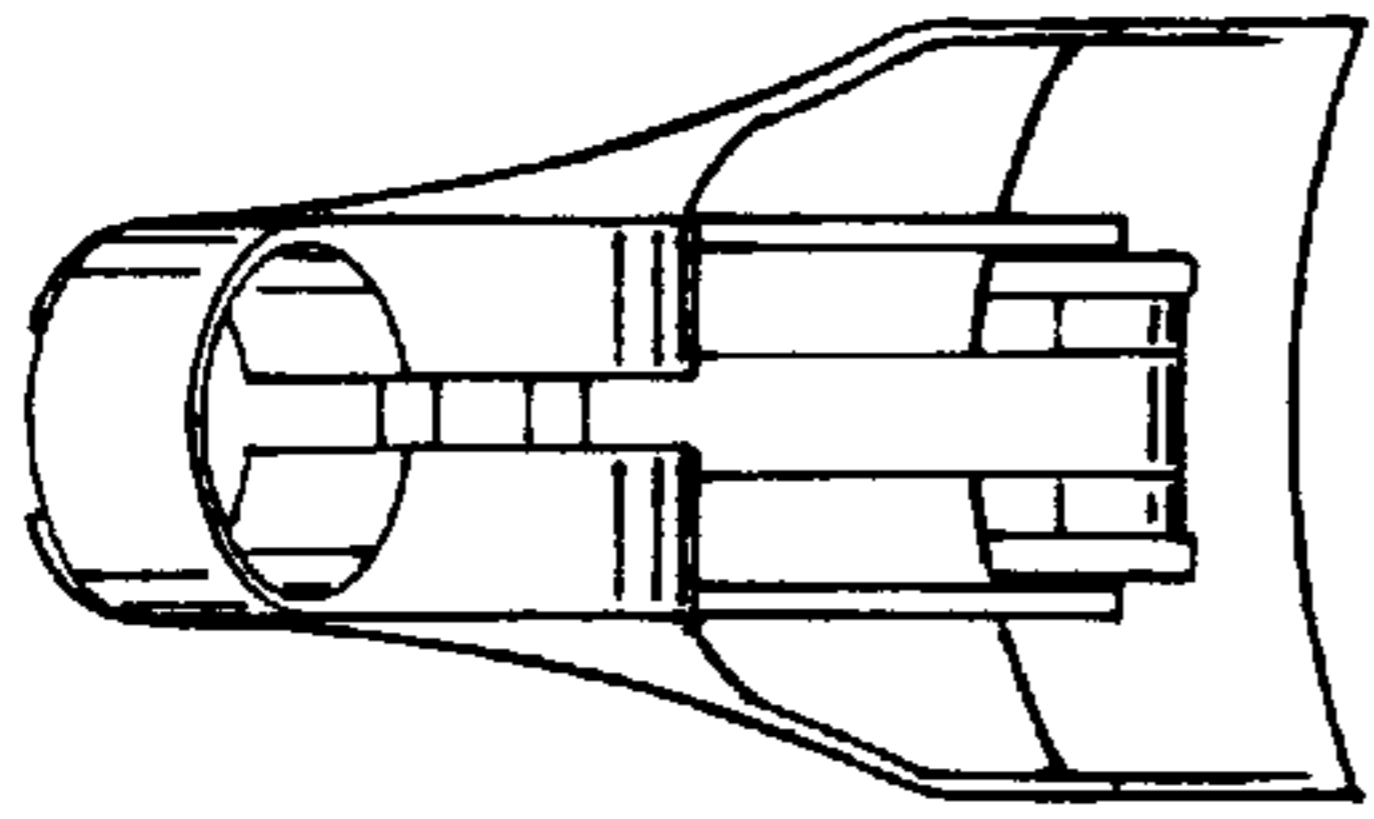

FIG. 4

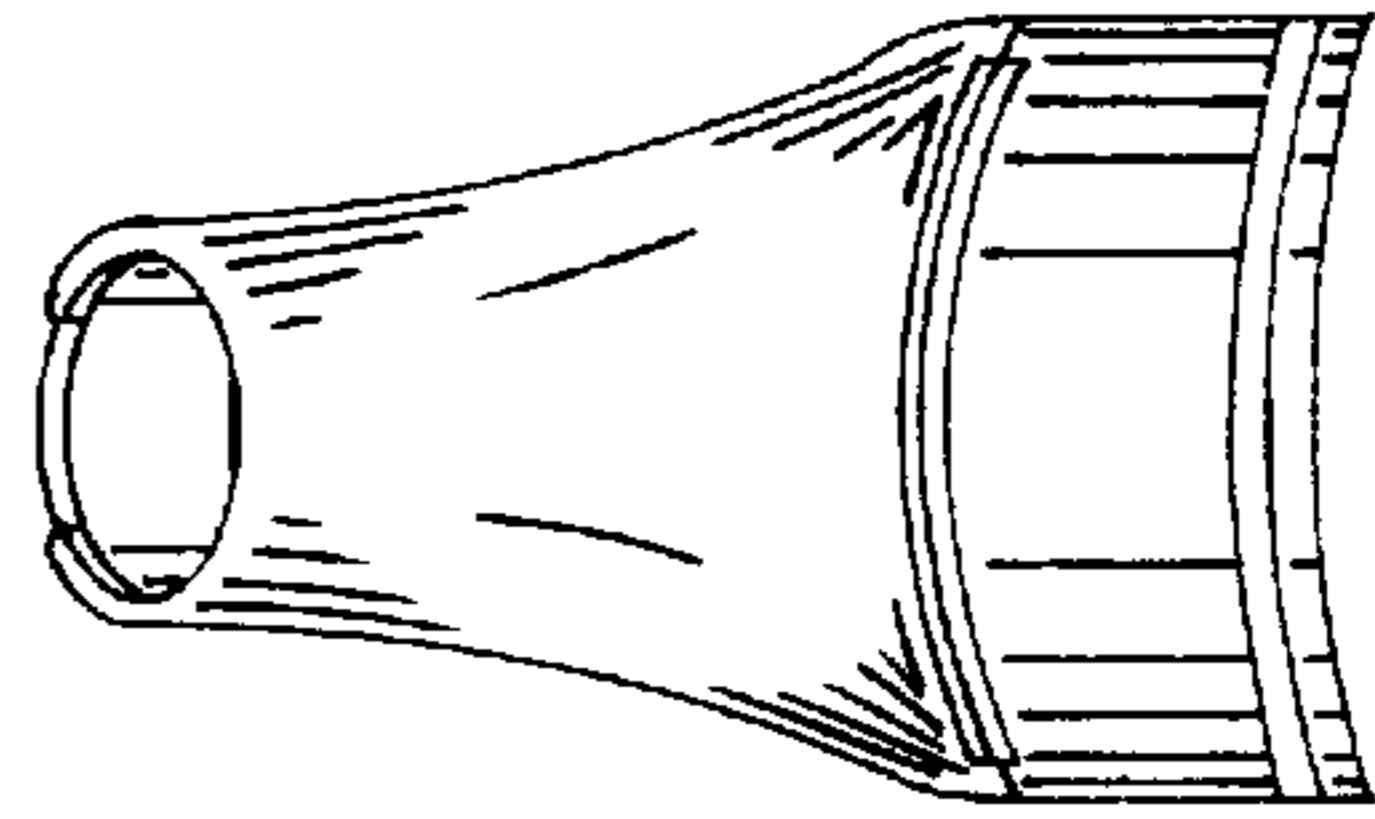

FIG. 5

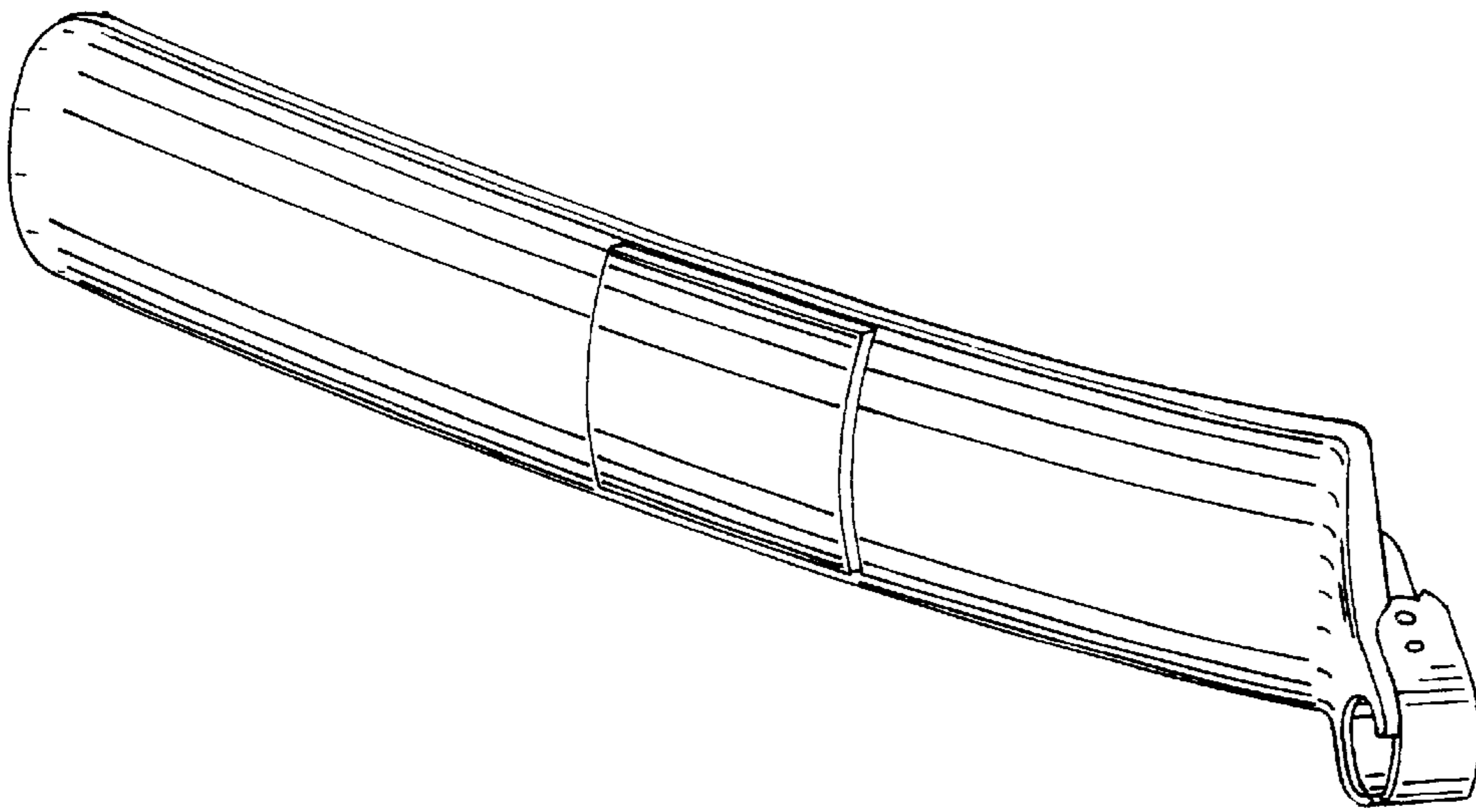

FIG. 6

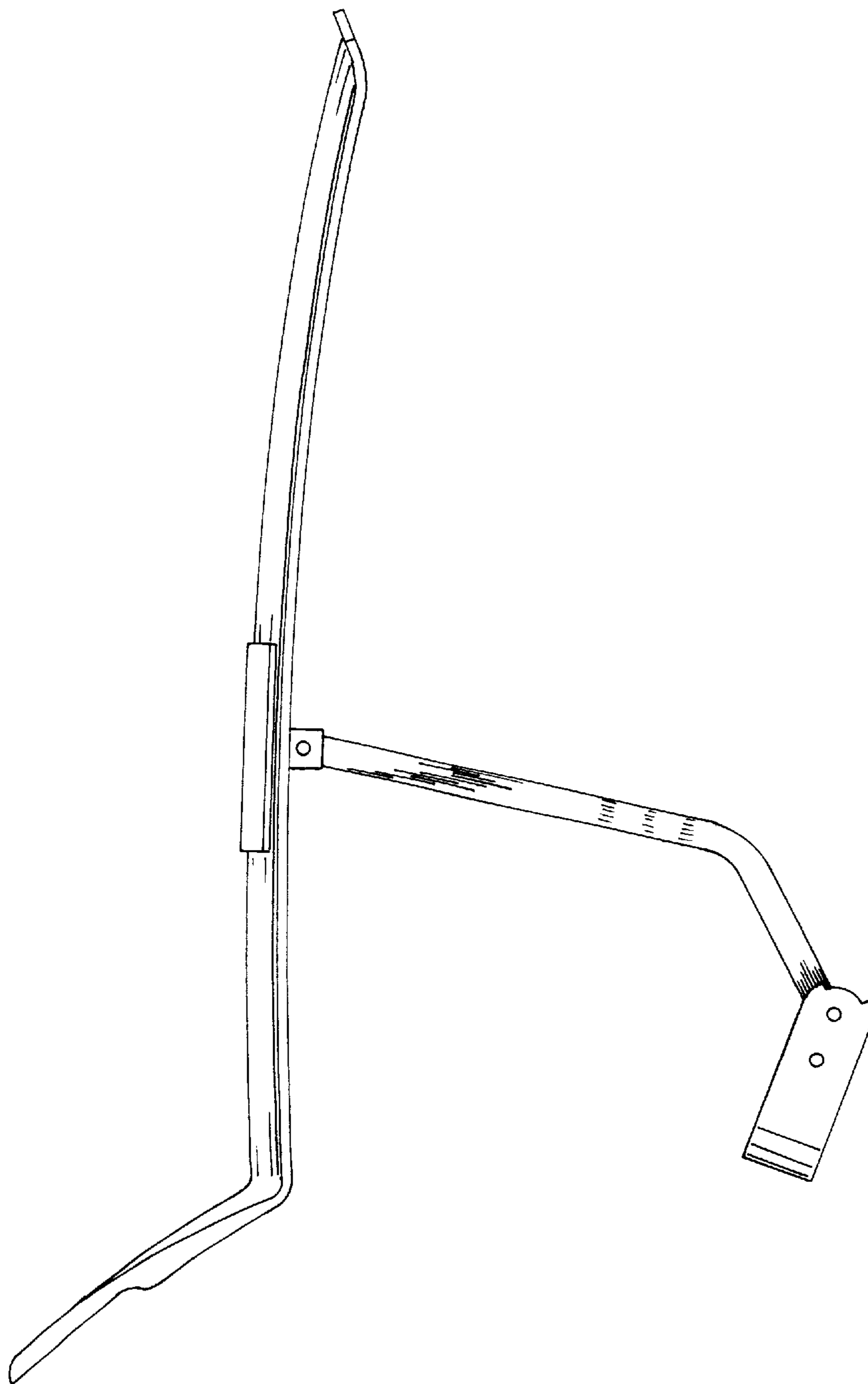

FIG. 7

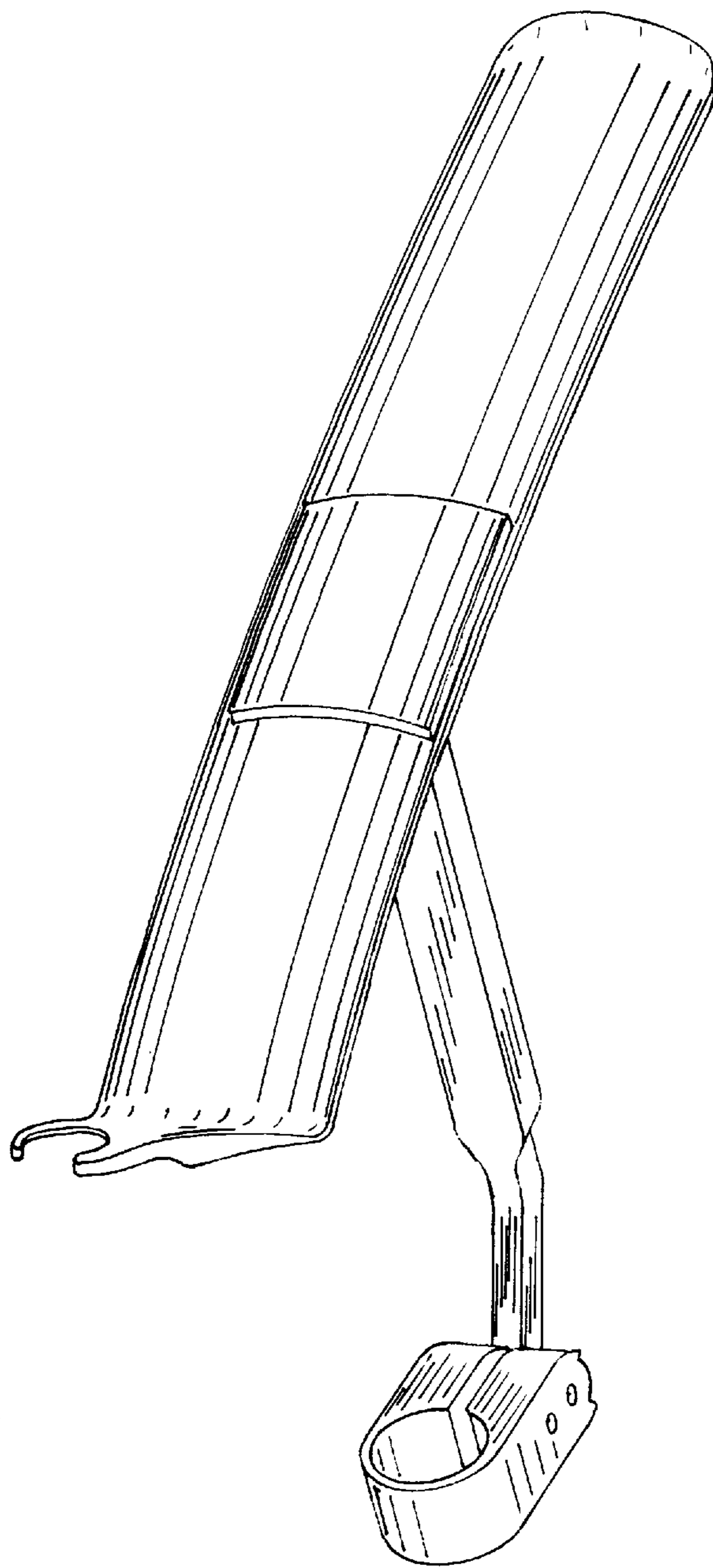

FIG. 8