



US00D395247S

**United States Patent** [19]  
**Bidwell**

[11] **Patent Number: Des. 395,247**

[45] **Date of Patent: \*\*Jun. 16, 1998**

[54] **CENTERLINE HUB BODY**

5,479,721 1/1996 Wickander ..... 33/542.1 XZ  
5,548,901 8/1996 Isler ..... 33/542 XZ

[75] **Inventor: Steven T. Bidwell, Ellington, Conn.**

[73] **Assignee: Bidwell Corporation, Enfield, Conn.**

[\*\*] **Term: 14 Years**

*Primary Examiner*—Antoine Duval Davis  
*Attorney, Agent, or Firm*—Richard H. Kosakowski, Esq.;  
Holland & Bonzagni, P.C.

[21] **Appl. No.: 43,840**

[57] **CLAIM**

[22] **Filed: Sep. 11, 1995**

The ornamental design for a centerline hub body, as shown.

[51] **LOC (6) Cl. .... 10-04**

**DESCRIPTION**

[52] **U.S. Cl. .... D10/65**

FIG. 1 is a front elevation view of a centerline hub body showing my new design;

[58] **Field of Search** ..... D10/64, 65; 38/542,

FIG. 2 is a top plan view;

38/542.1, 543, 544, 544.1, 544.2, 544.3,  
544.4, 544.5, 544.6

FIG. 3 is a bottom plan view;

FIG. 4 is a rear elevation view; and,

[56] **References Cited**

FIG. 5 is a left side elevation view, the opposite side view being a mirror image thereof.

**U.S. PATENT DOCUMENTS**

3,238,626 3/1966 White ..... 33/542

**1 Claim, 3 Drawing Sheets**

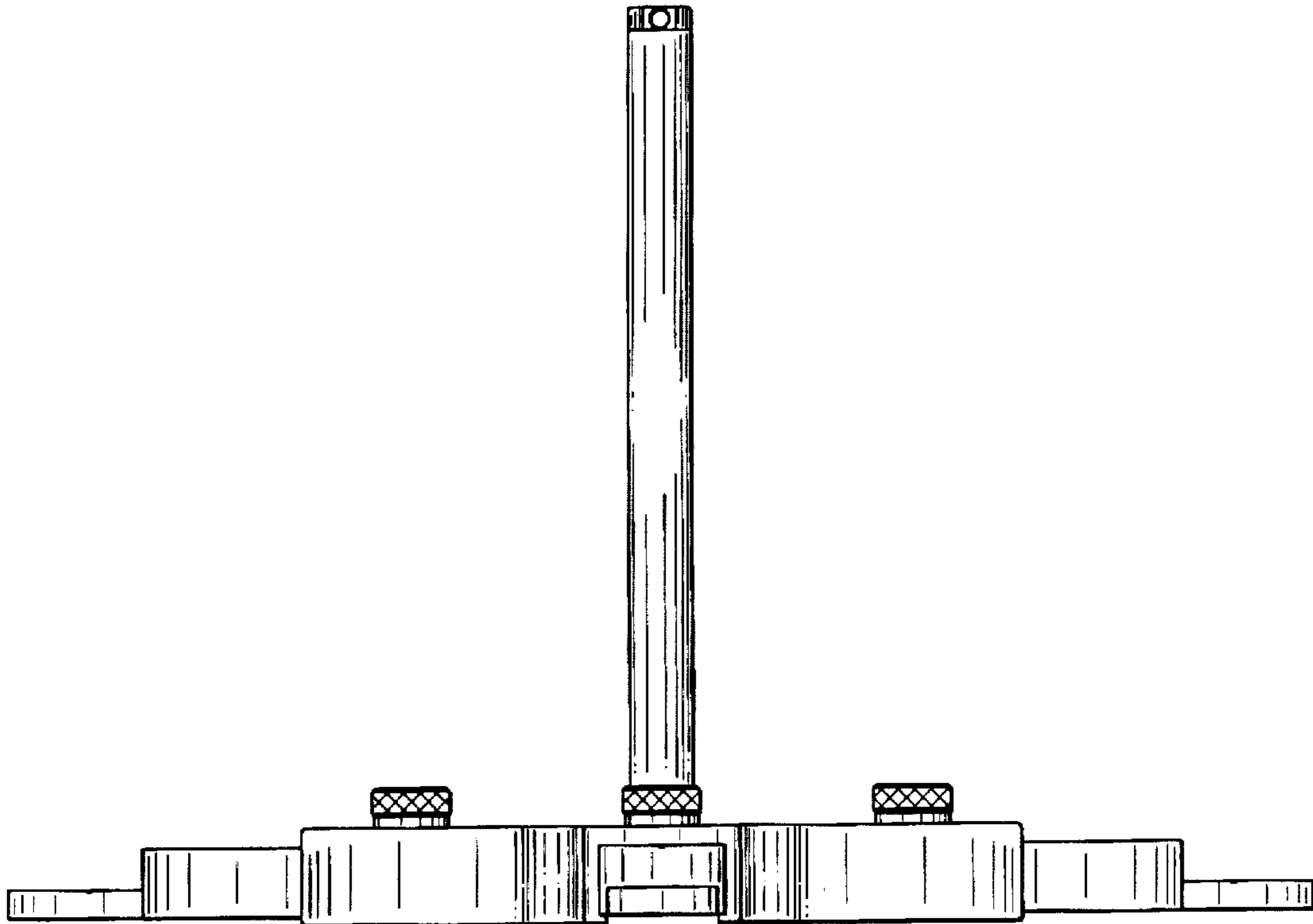

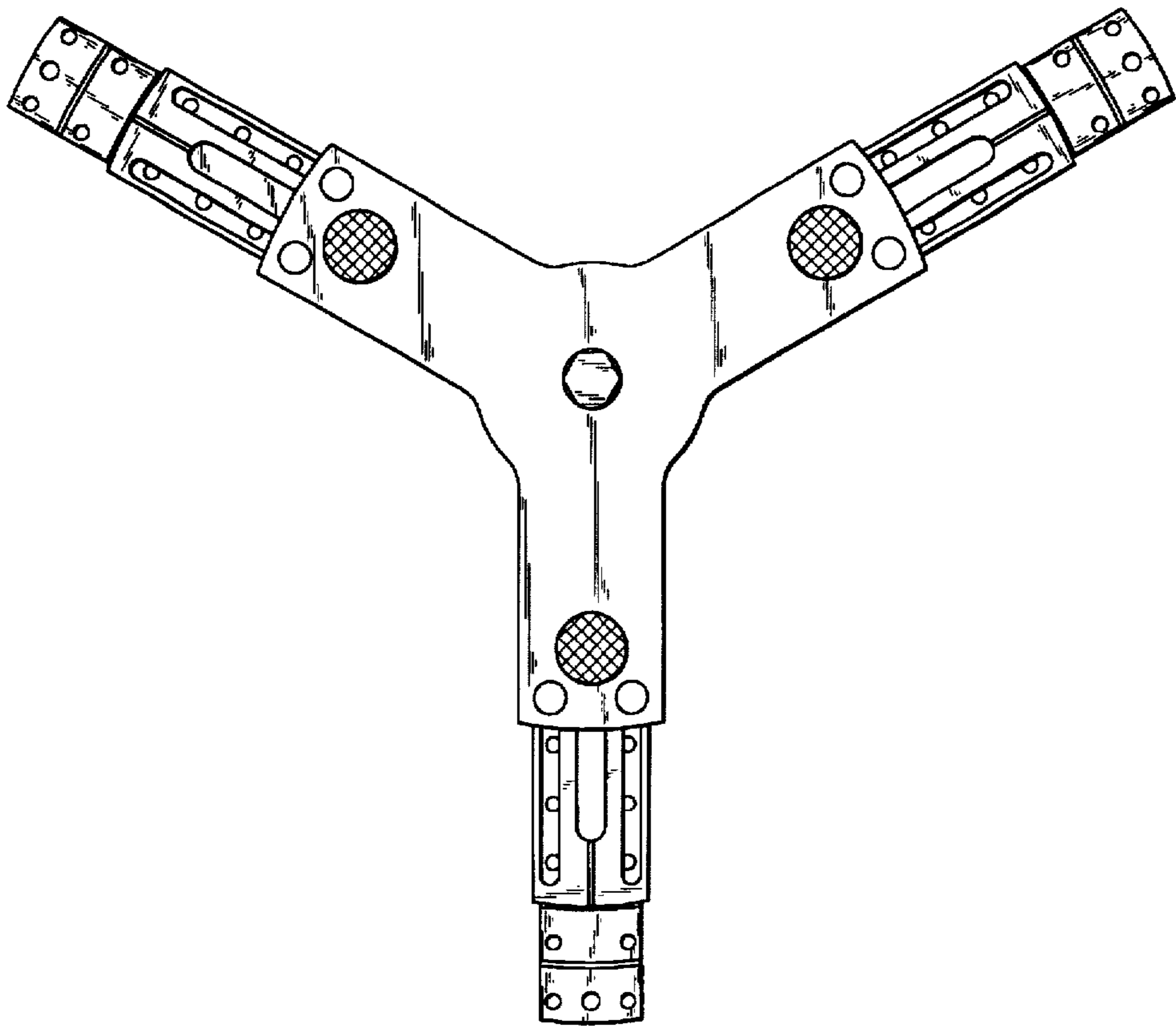

FIG. 2

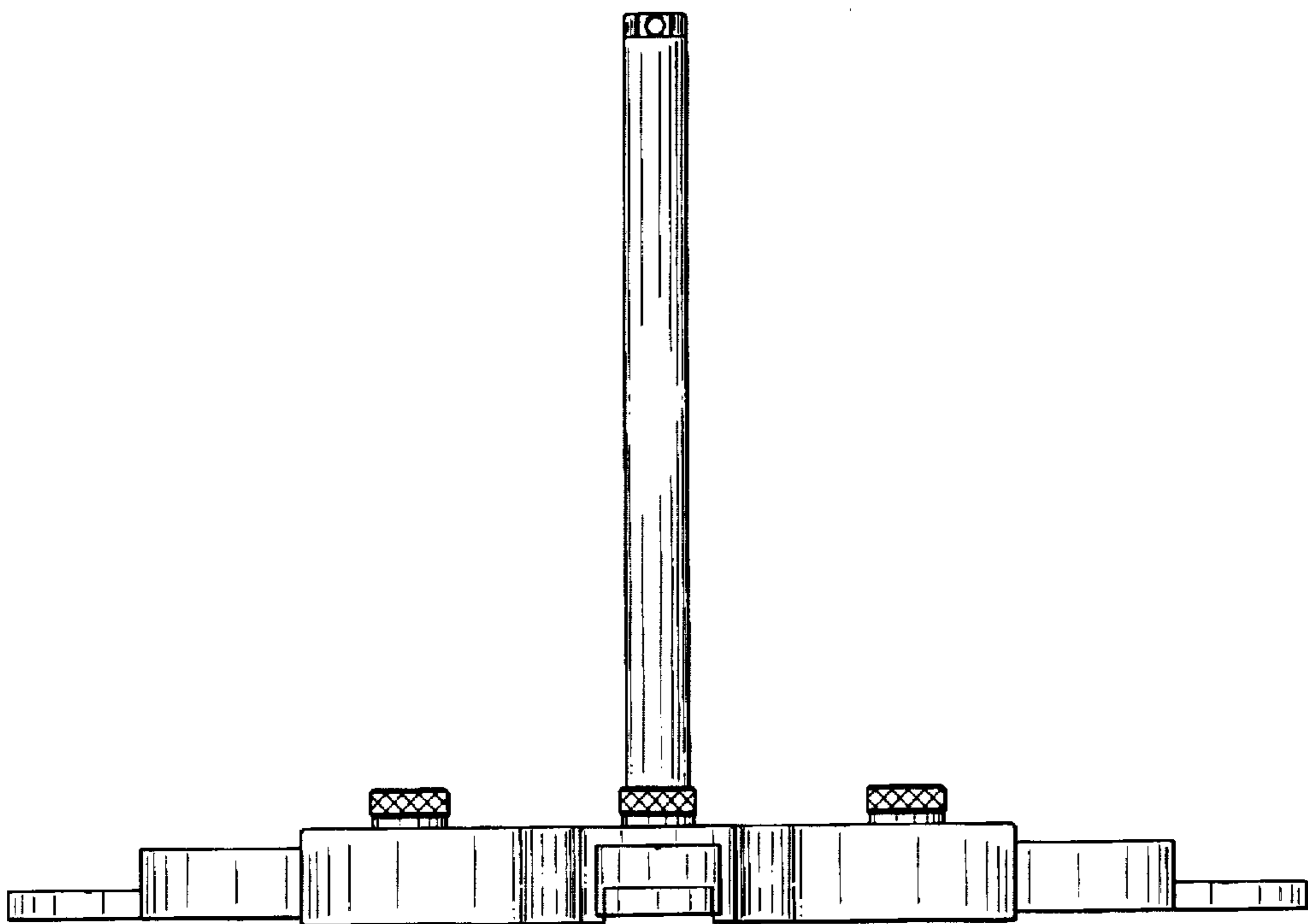

FIG. 1

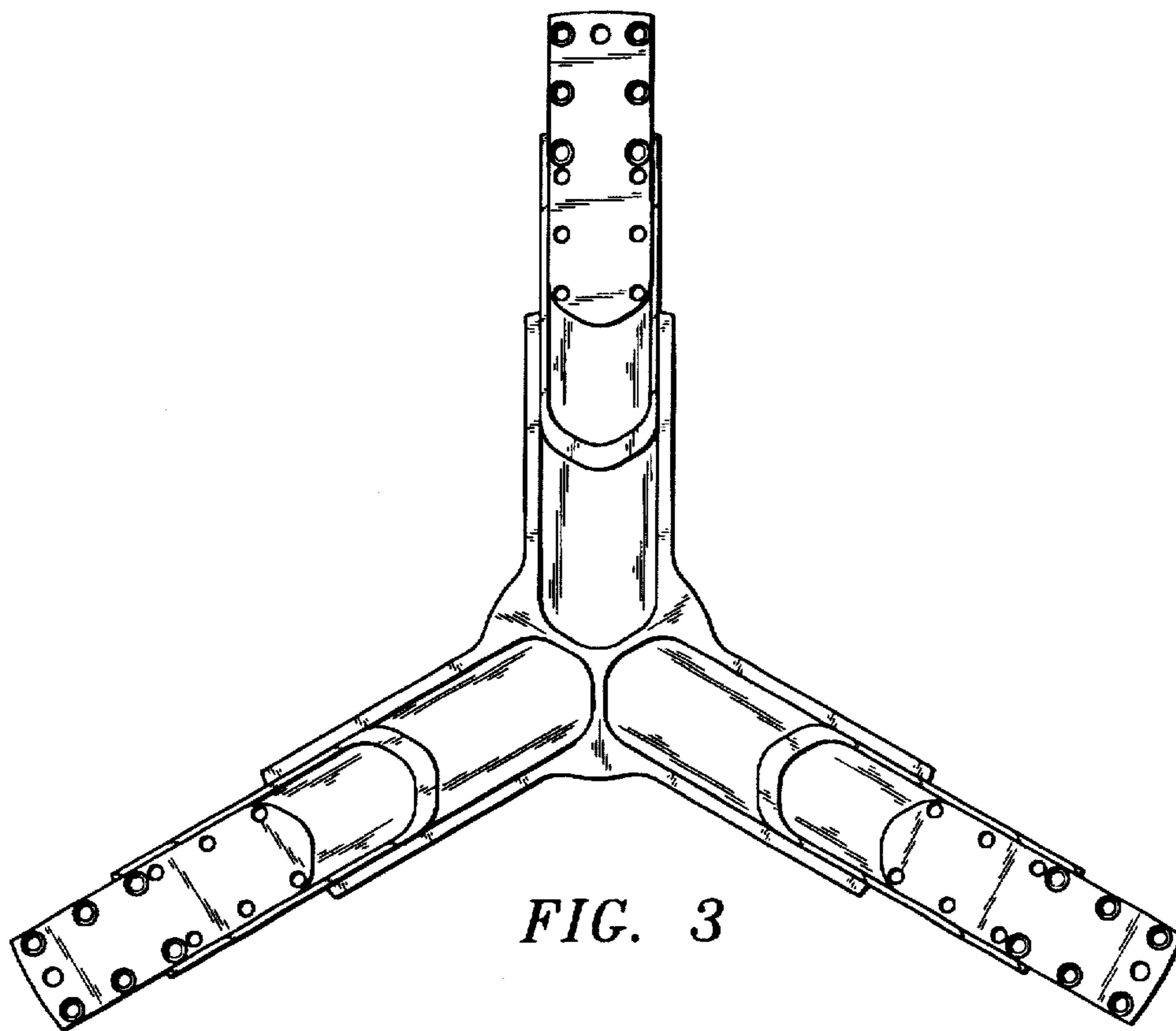

FIG. 3

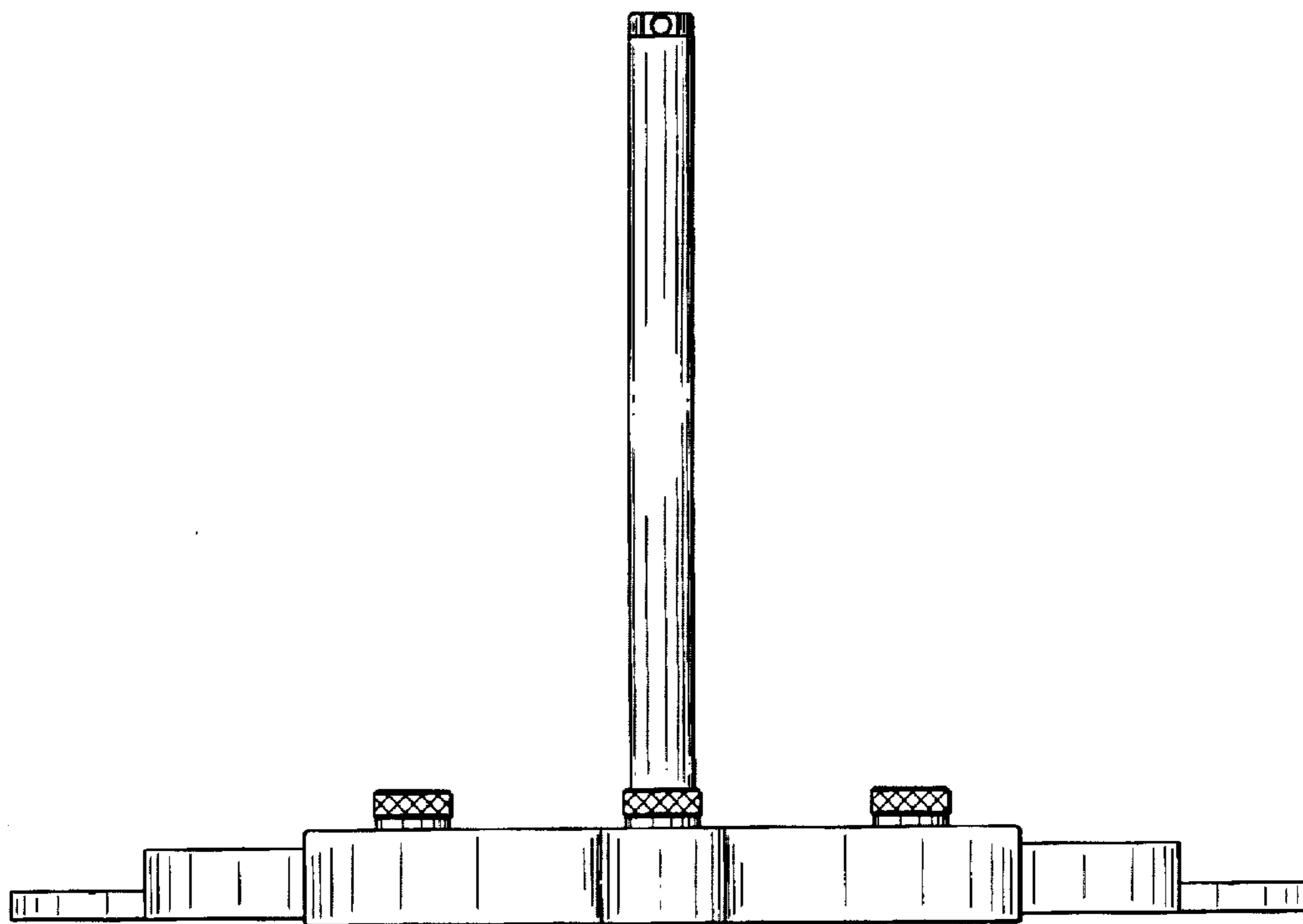
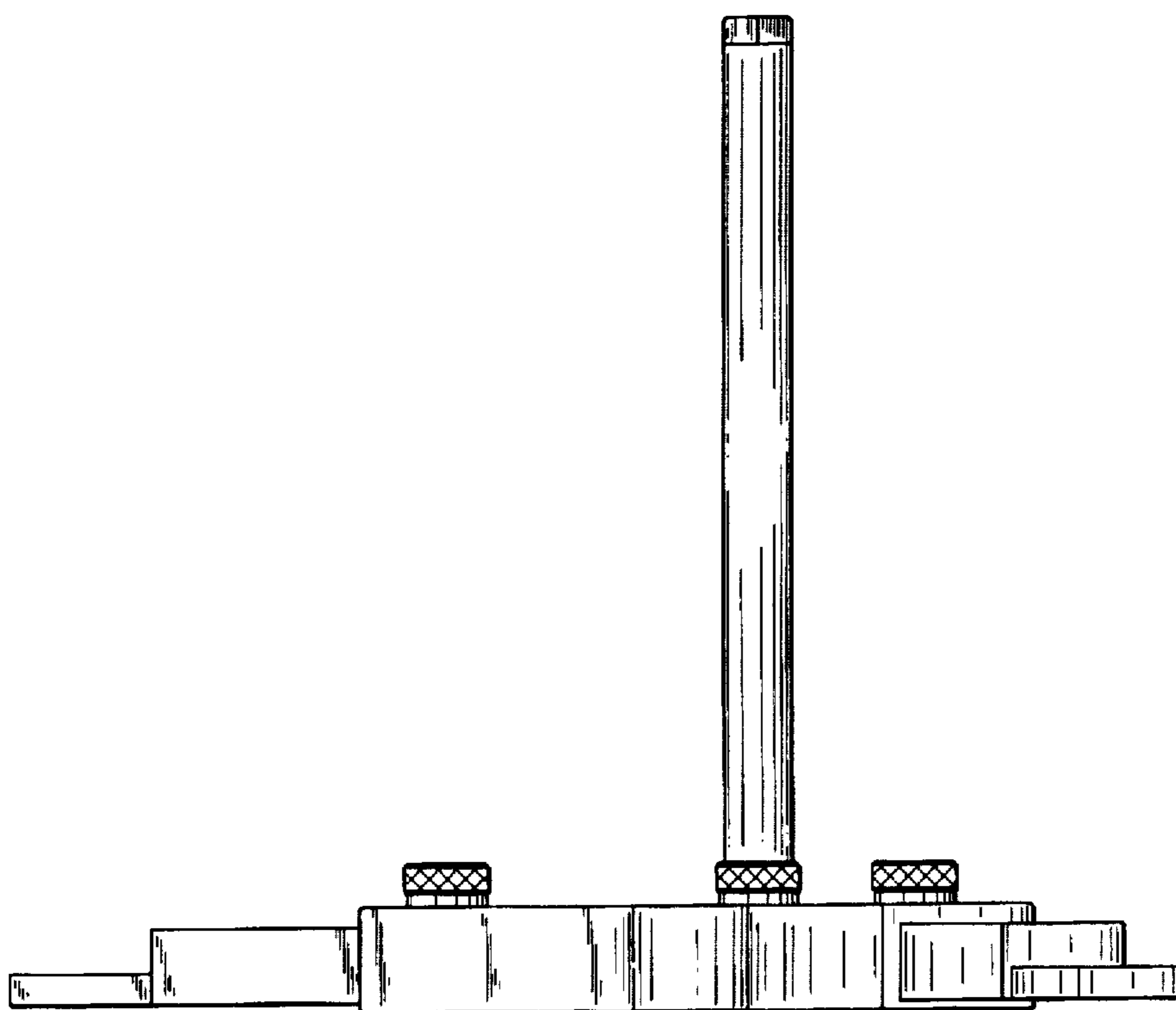

FIG. 4



*FIG. 5*