



US00D395105S

United States Patent [19]
Stallbaumer

[11] **Patent Number:** **Des. 395,105**
[45] **Date of Patent:** ****Jun. 9, 1998**

[54] **HAND TRUCK**

[75] **Inventor:** **John J. Stallbaumer**, Wichita, Kans.

[73] **Assignee:** **Harper Trucks, Inc.**, Wichita, Kans.

[**] **Term:** **14 Years**

[21] **Appl. No.:** **66,962**

[22] **Filed:** **Feb. 28, 1997**

[51] **LOC (6) Cl.** **12-02**

[52] **U.S. Cl.** **D34/12; D34/26**

[58] **Field of Search** **D34/12-27; 280/47.18,**
280/47.28, 47.34, 654, 655, 47.19

[56] **References Cited**

U.S. PATENT DOCUMENTS

D. 330,959	11/1992	Apter et al.	D34/26
D. 364,022	11/1995	Kazmark, Jr.	D34/26
5,630,601	5/1997	Vom Braucke et al.	280/655

Primary Examiner—Kay H. Chin
Attorney, Agent, or Firm—Edward L. Brown, Jr.

[57] **CLAIM**

The ornamental design for a “hand truck,” as shown and described.

DESCRIPTION

FIG. 1 is a front elevational view of the “hand truck;”

FIG. 2 is a right side elevational view;

FIG. 3 is a back elevational view;

FIG. 4 is a top view;

FIG. 5 is a bottom view; and,

FIG. 6 is a perspective view from the left side.

The left side elevational view is a mirror image of the right side.

The broken lines are for illustrative purposes only and form no part of the claimed design.

1 Claim, 2 Drawing Sheets

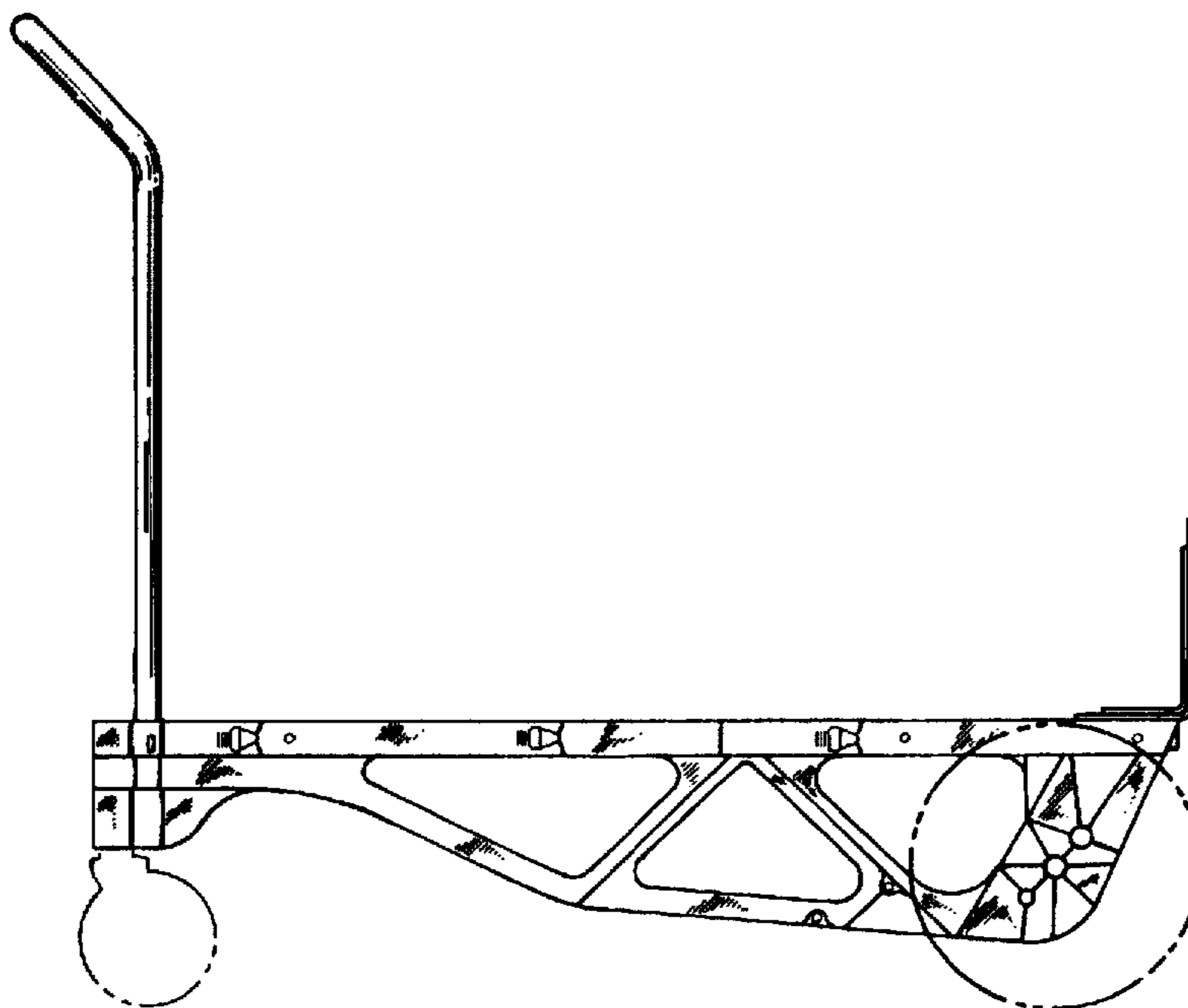

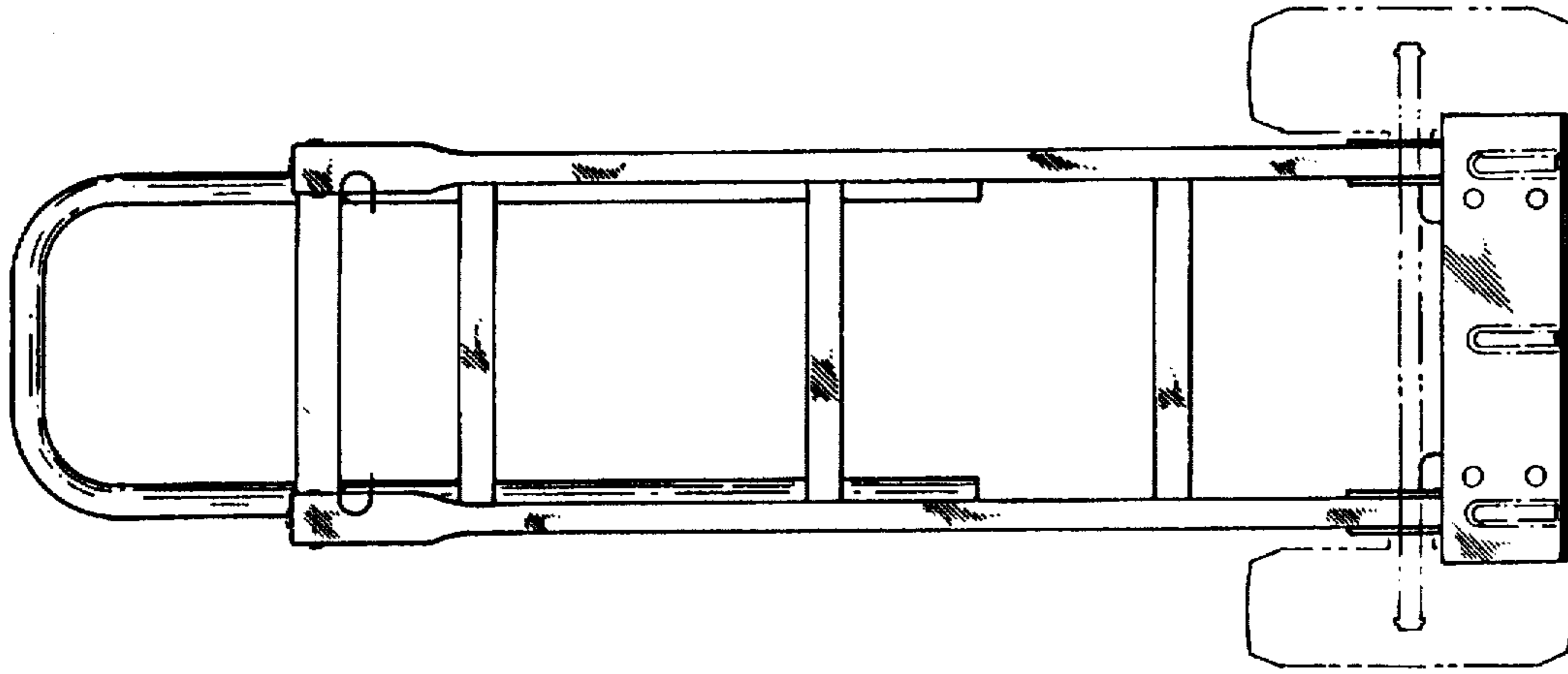

FIG 1

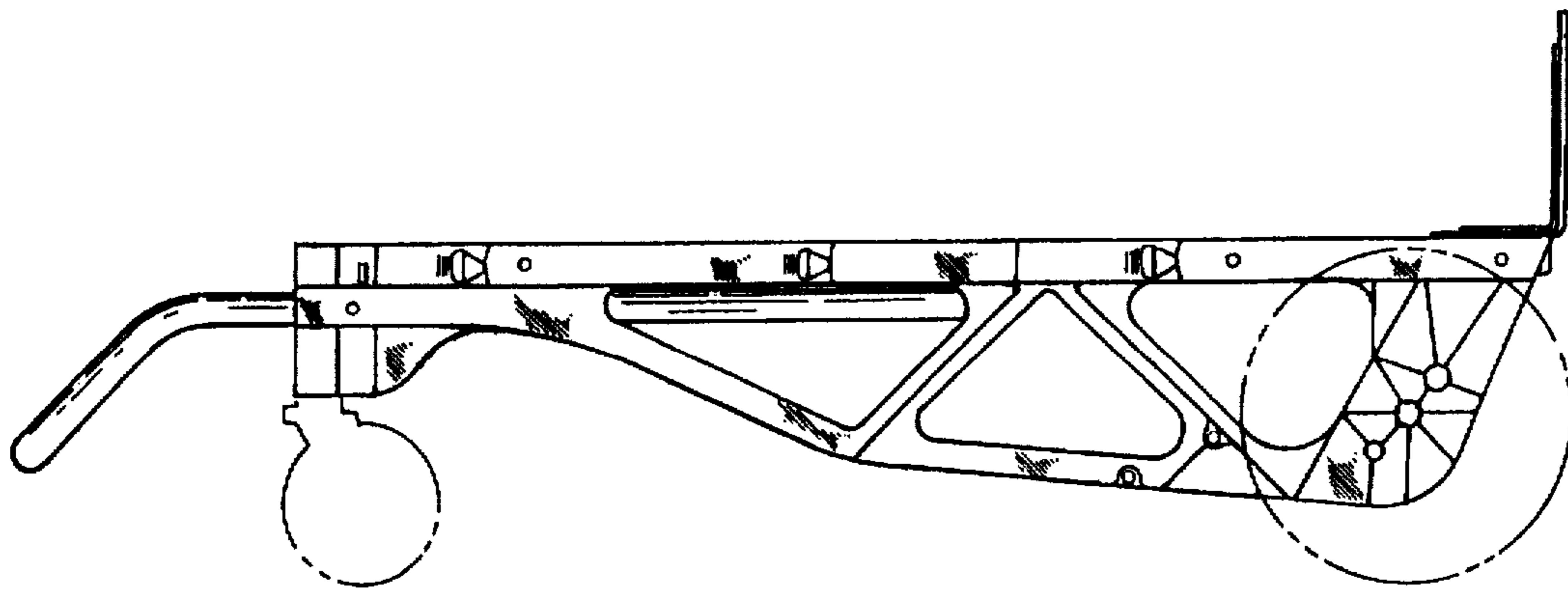

FIG 2

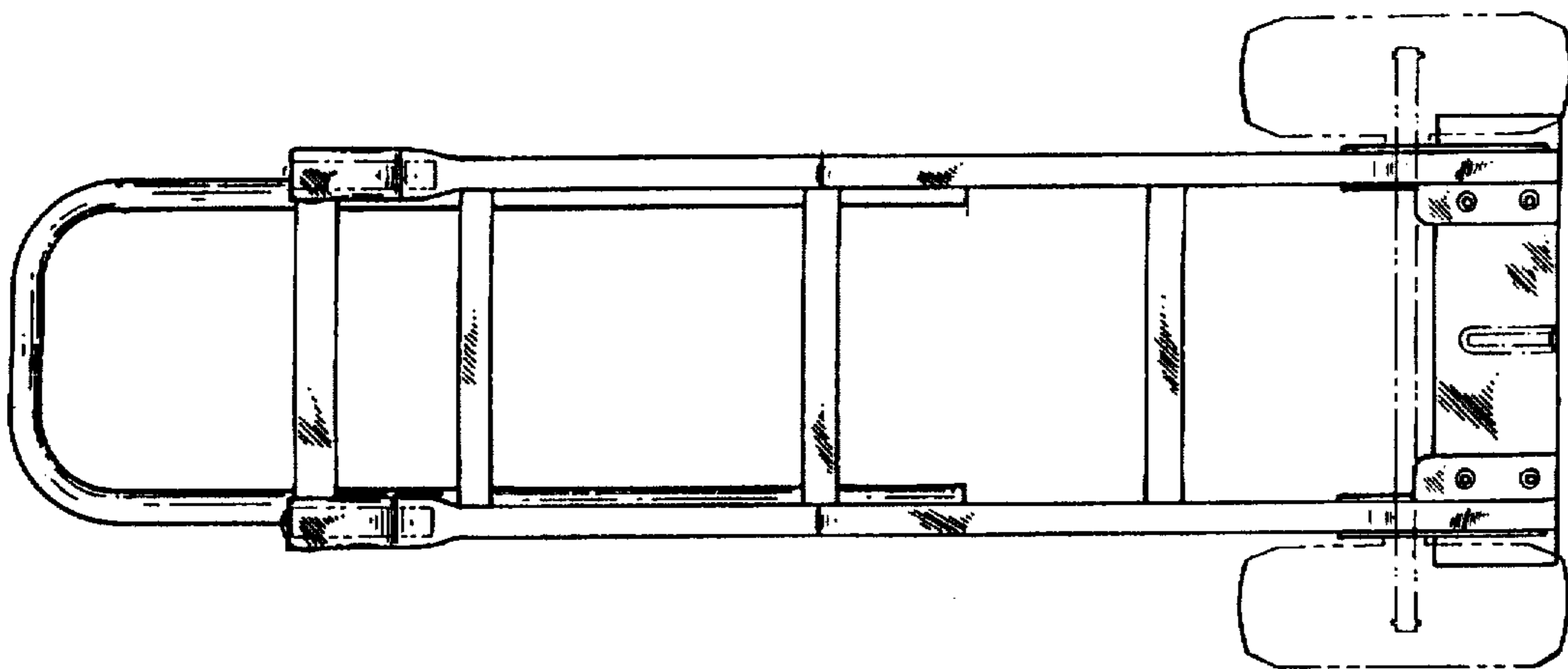

FIG 3

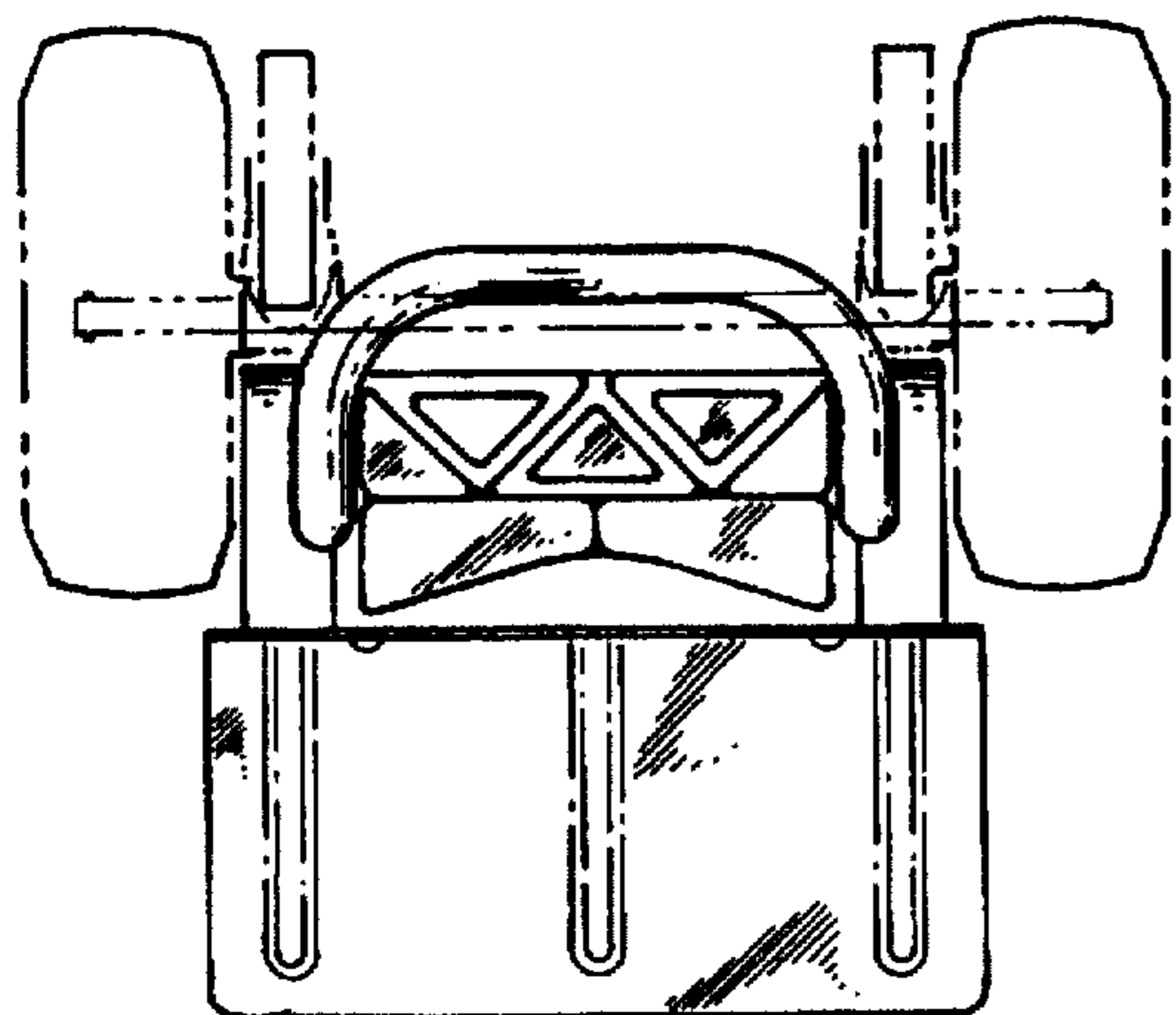

FIG 4

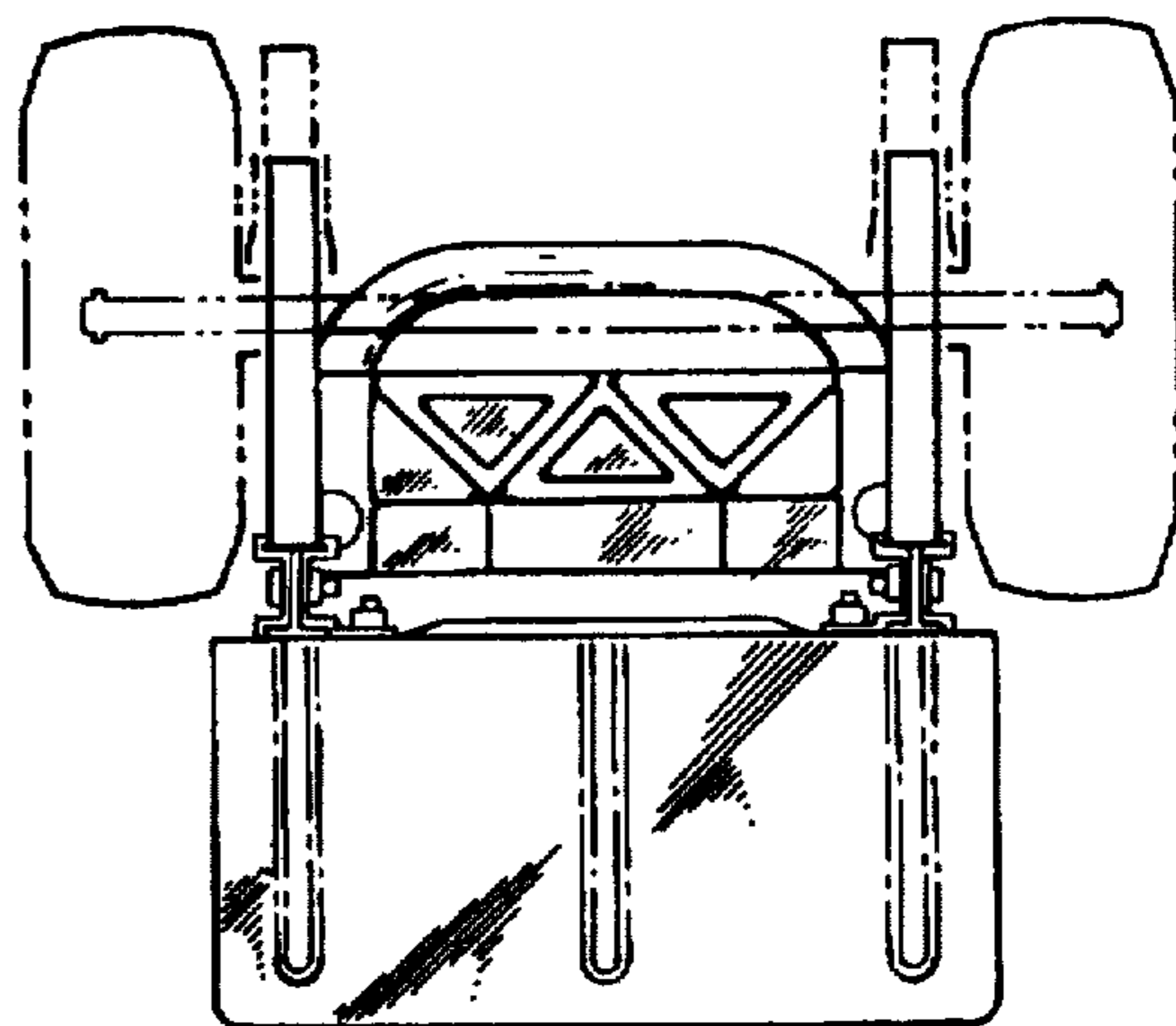

FIG 5

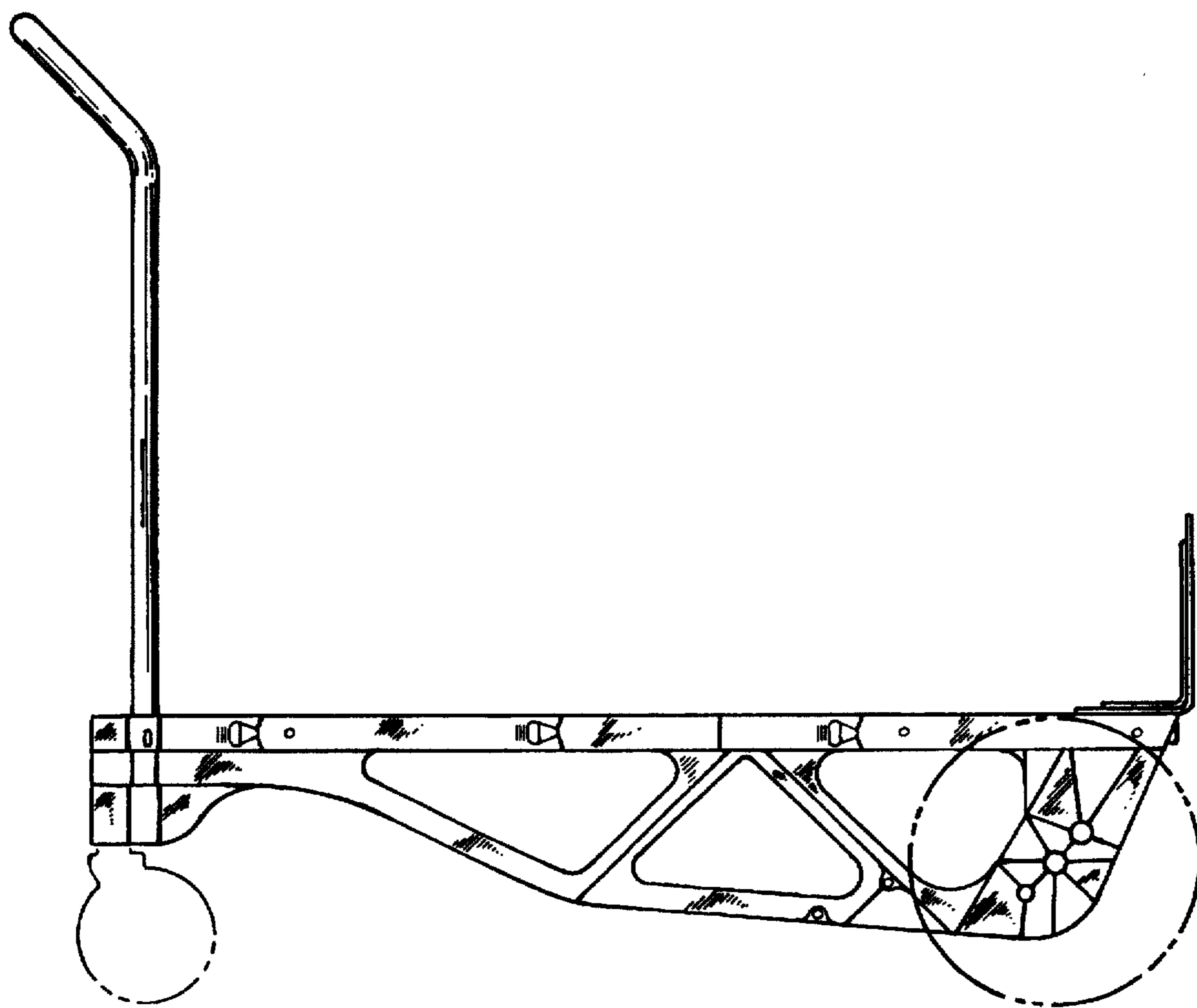

FIG 6