



US00D394624S

United States Patent [19]

Allendorph et al.

[11] Patent Number: **Des. 394,624**

[45] Date of Patent: ****May 26, 1998**

[54] **EXTERIOR SHELL OF A VEHICLE HOOD**

[75] Inventors: **L. David Allendorph**, Fort Wayne;
Robert M. Zimmerman, Kendalville,
both of Ind.

[73] Assignee: **Navistar International Transportation Corp.**, Chicago, Ill.

[**] Term: **14 Years**

[21] Appl. No.: **35,290**

[22] Filed: **Feb. 24, 1995**

[51] LOC (6) Cl. **12-16**

[52] U.S. Cl. **D12/173**

[58] Field of Search D12/82, 93, 96,
D12/97, 99, 173; 180/89.12, 89.13, 89.18,
89.19, 69.2; 296/183-190

[56] **References Cited**

U.S. PATENT DOCUMENTS

D. 306,714	3/1990	Allendorph	D12/173
D. 307,126	4/1990	Allendorph et al.	D12/173
D. 328,273	7/1992	McGrew, Jr. et al.	D12/173
D. 366,638	1/1996	Tucker et al.	D12/173

OTHER PUBLICATIONS

Chilton's Commercial Carrier Journal, vol. 151 Freightliner Business Class Truck, p. 1, Mar. 1994.
"5000 Set-Forward Axle (SFA) Paystar®" Brochure No. AD-432684, Navistar Int'l Transportation Corp., Mar., 1994.

"Ford Aeroforce" Brochure No. FTO-2159, Ford Motor Company, Jan., 1991 pp. 10-14 & 20.

Primary Examiner—Alan P. Douglas
Assistant Examiner—Lavone D. Tabor
Attorney, Agent, or Firm—Dennis K. Sullivan; Jeffrey P. Calfa

[57] **CLAIM**

The ornamental design for an exterior shell of a vehicle hood, as shown and described.

DESCRIPTION

FIG. 1 is a left, front perspective view of an exterior shell of a vehicle hood showing our new design, it being understood that the broken lines are for illustrative purposes only and form no part of the claimed design;

FIG. 2 is a left side elevation view thereof;

FIG. 3 is a right side elevation view thereof;

FIG. 4 is a front elevation view thereof; and,

FIG. 5 is a top plan view thereof.

1 Claim, 2 Drawing Sheets

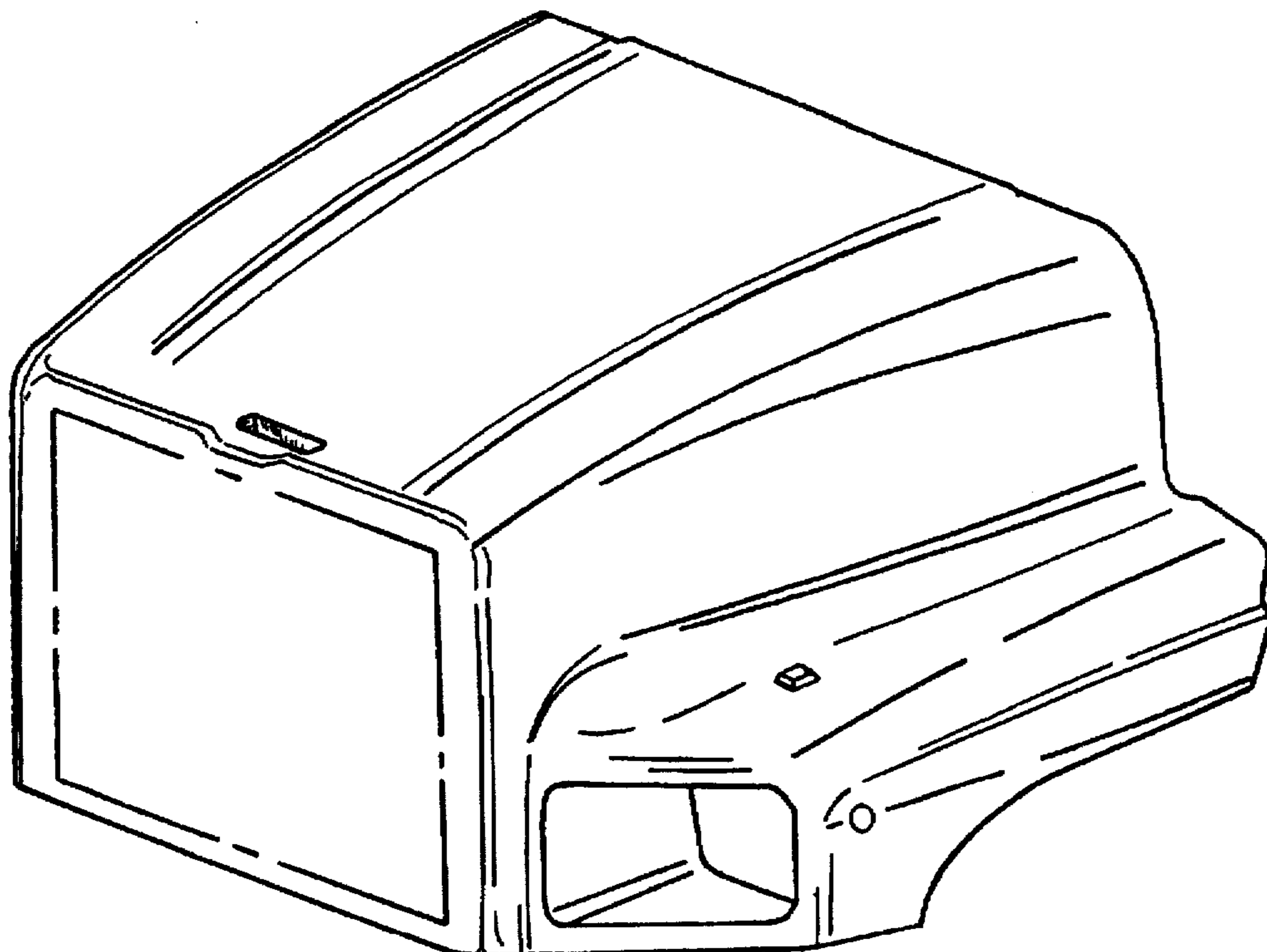

FIG. 1

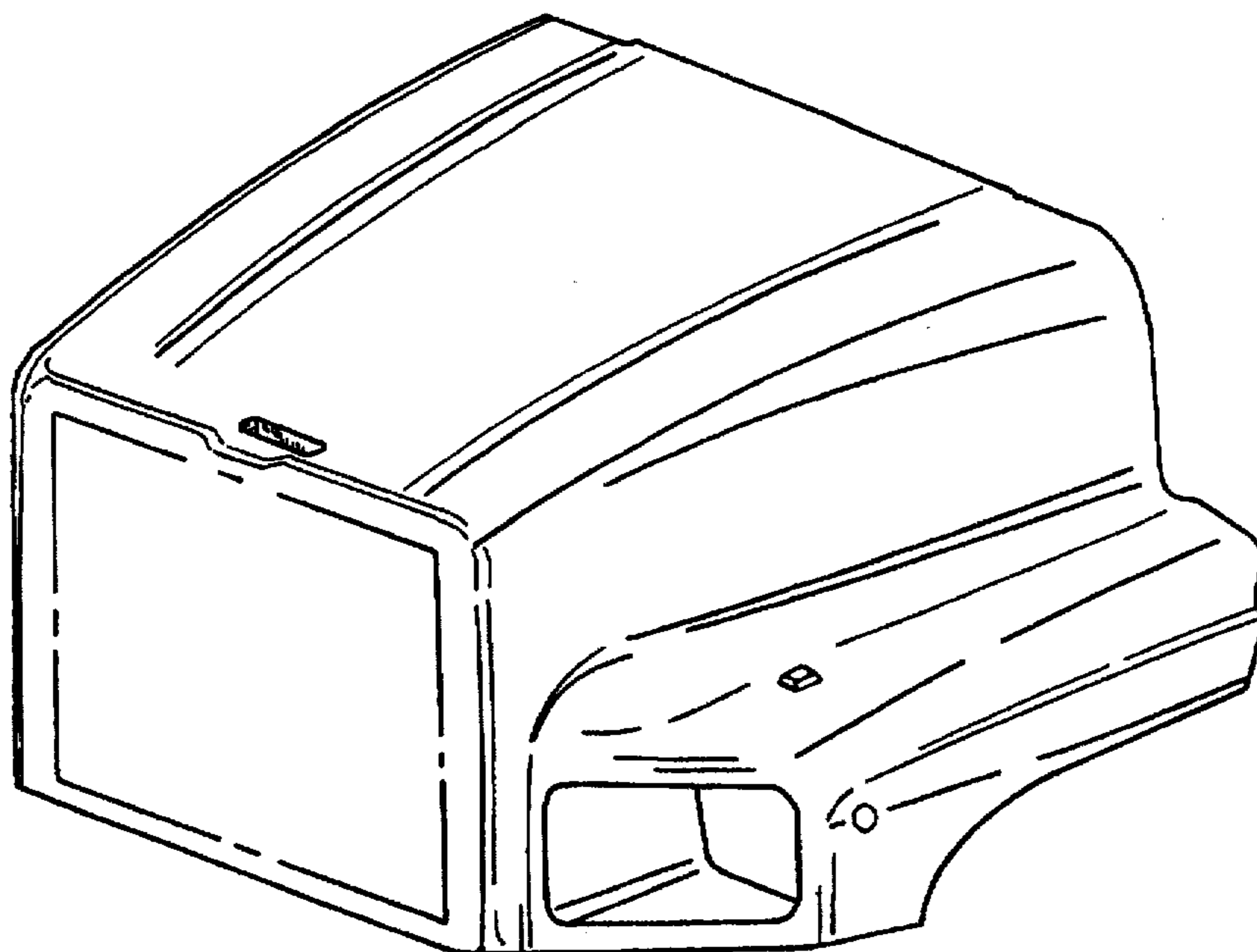

FIG. 2

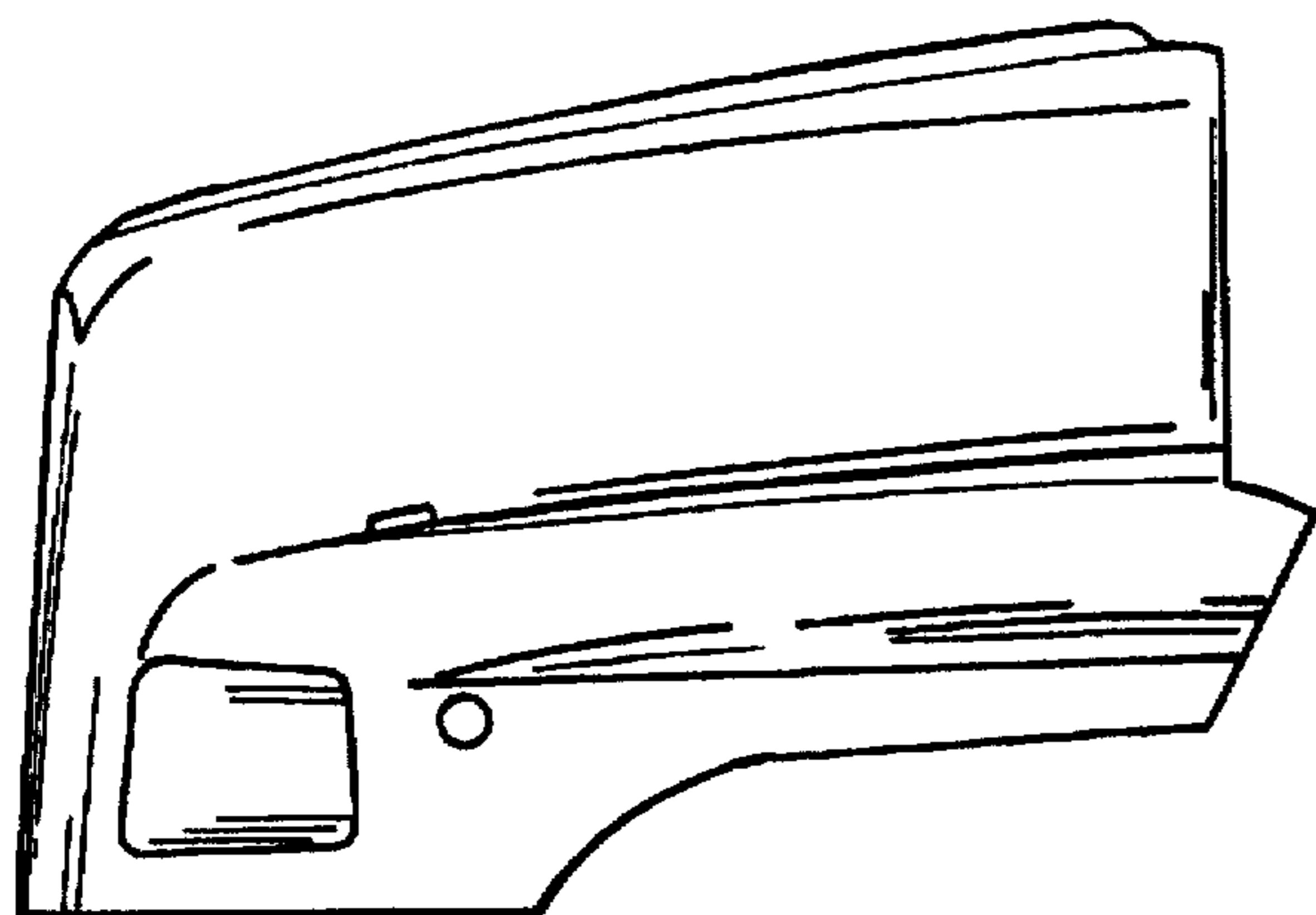

FIG. 3

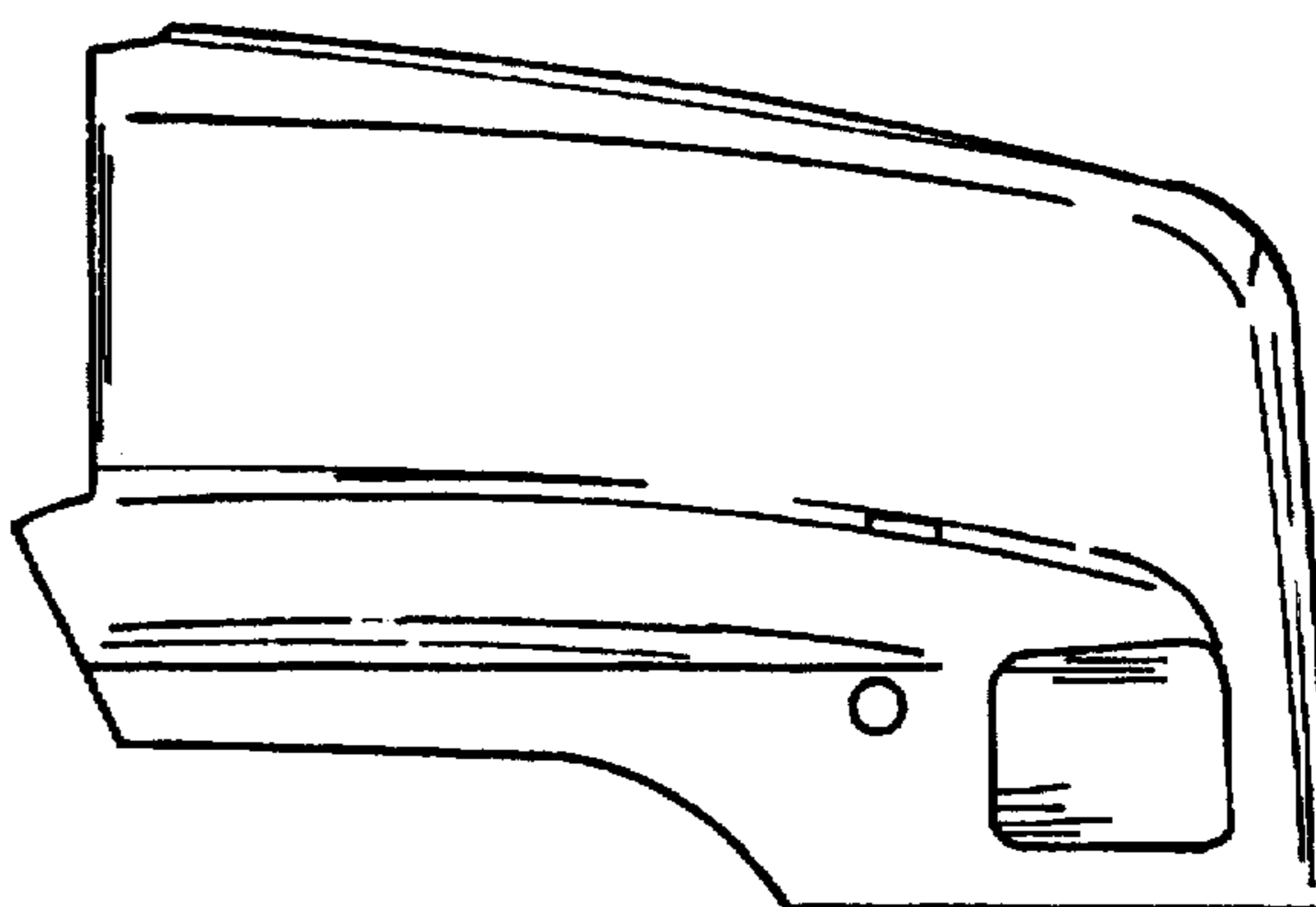

FIG. 4

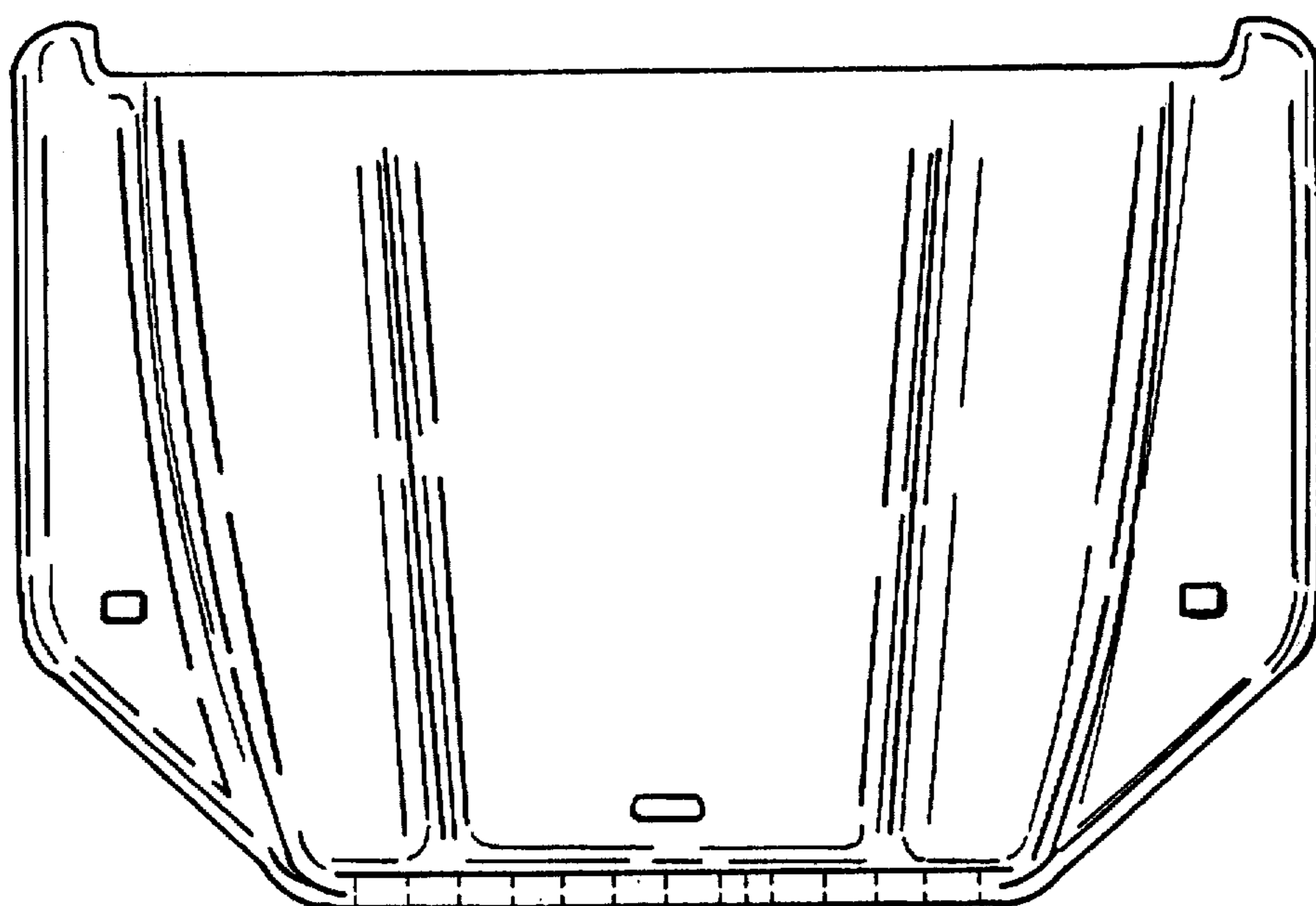
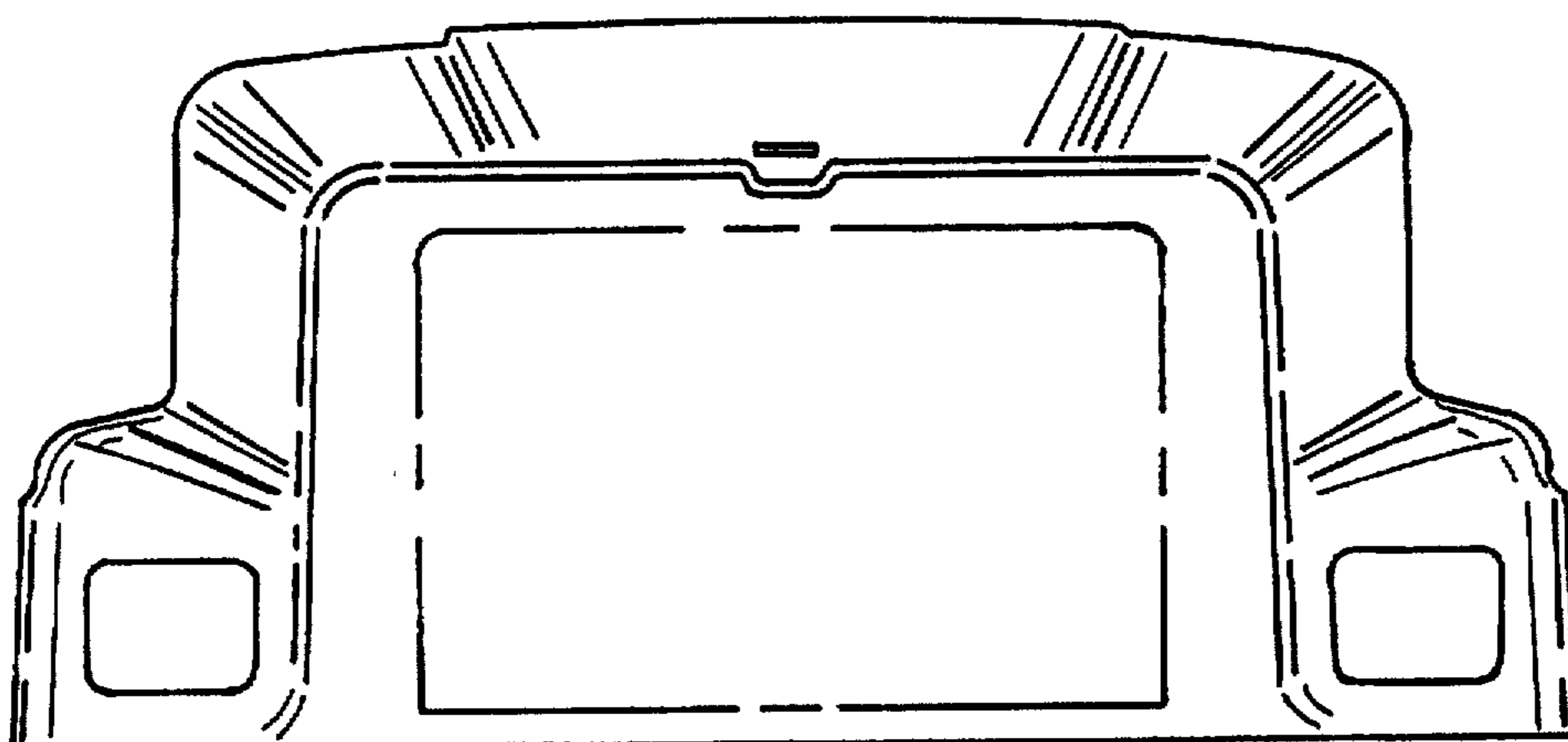

FIG. 5