



US00D394423S

United States Patent [19]

[11] Patent Number: **Des. 394,423**

Nagele et al.

[45] Date of Patent: ****May 19, 1998**

[54] BATTERY CHARGER

[75] Inventors: **Albert L. Nagele**, Wilmette; **Leonid Soren**, Lincolnwood; **James D. Domoleczny**, Lindenhurst, all of Ill.; **Steven R. Remy**, Atlanta; **Willard F. Amero, Jr.**, Flowering Branch, both of Ga.

[73] Assignee: **Motorola, Inc.**, Schaumburg, Ill.

[**] Term: **14 Years**

[21] Appl. No.: **69,610**

[22] Filed: **May 5, 1997**

Related U.S. Application Data

[63] Continuation of Ser. No. 45,836, Oct. 31, 1995, abandoned.

[51] LOC (6) Cl. **13-02**

[52] U.S. Cl. **D13/107**

[58] Field of Search D13/107, 108;
D14/149, 251; 320/2, 3, 4, 15

[56] References Cited

U.S. PATENT DOCUMENTS

D. 328,889	8/1992	Seki	D13/108
D. 345,728	4/1994	Tyneski et al.	D13/108
D. 350,540	9/1994	Hyvonen	D13/108 X
D. 353,131	12/1994	Nagele	D13/107
D. 358,364	5/1995	Siddoway	D13/108
D. 358,821	5/1995	Hellier et al.	D13/108 X
D. 361,979	9/1995	Shirakawa et al.	D13/108
D. 368,892	4/1996	Tanaka	D13/108
5,059,885	10/1991	Weiss et al.	320/2
5,256,954	10/1993	Chen	320/2

OTHER PUBLICATIONS

NTT Do Co Mo, Mo Va, 94-4, Japan pp. 1, 80, 90.

Primary Examiner—Joel Sincavage
Attorney, Agent, or Firm—Mark D. Patrick

[57] CLAIM

The ornamental design for a battery charger, as shown and described.

DESCRIPTION

FIG. 1 is a front, top, and right side perspective view showing our new design for a battery charger in full lines and broken lines, wherein the broken lines are for illustrative purposes only and form no part of the claimed design;

FIG. 2 is a left side elevational view of the battery charger according to FIG. 1;

FIG. 3 is a rear elevational view of the battery charger according to FIG. 1;

FIG. 4 is a bottom plan view of the battery charger according to FIG. 1;

FIG. 5 is a top plan view of the battery charger according to FIG. 1;

FIG. 6 is the front, top, and right side perspective view of FIG. 1 with the broken lines removed;

FIG. 7 is the left side elevational view of FIG. 2 with the broken lines removed;

FIG. 8 is a rear elevational view of FIG. 3 with the broken lines removed;

FIG. 9 is the bottom plan view of FIG. 4 with the broken lines removed; and,

FIG. 10 is the top plan view of FIG. 5 with the broken lines removed.

1 Claim, 8 Drawing Sheets

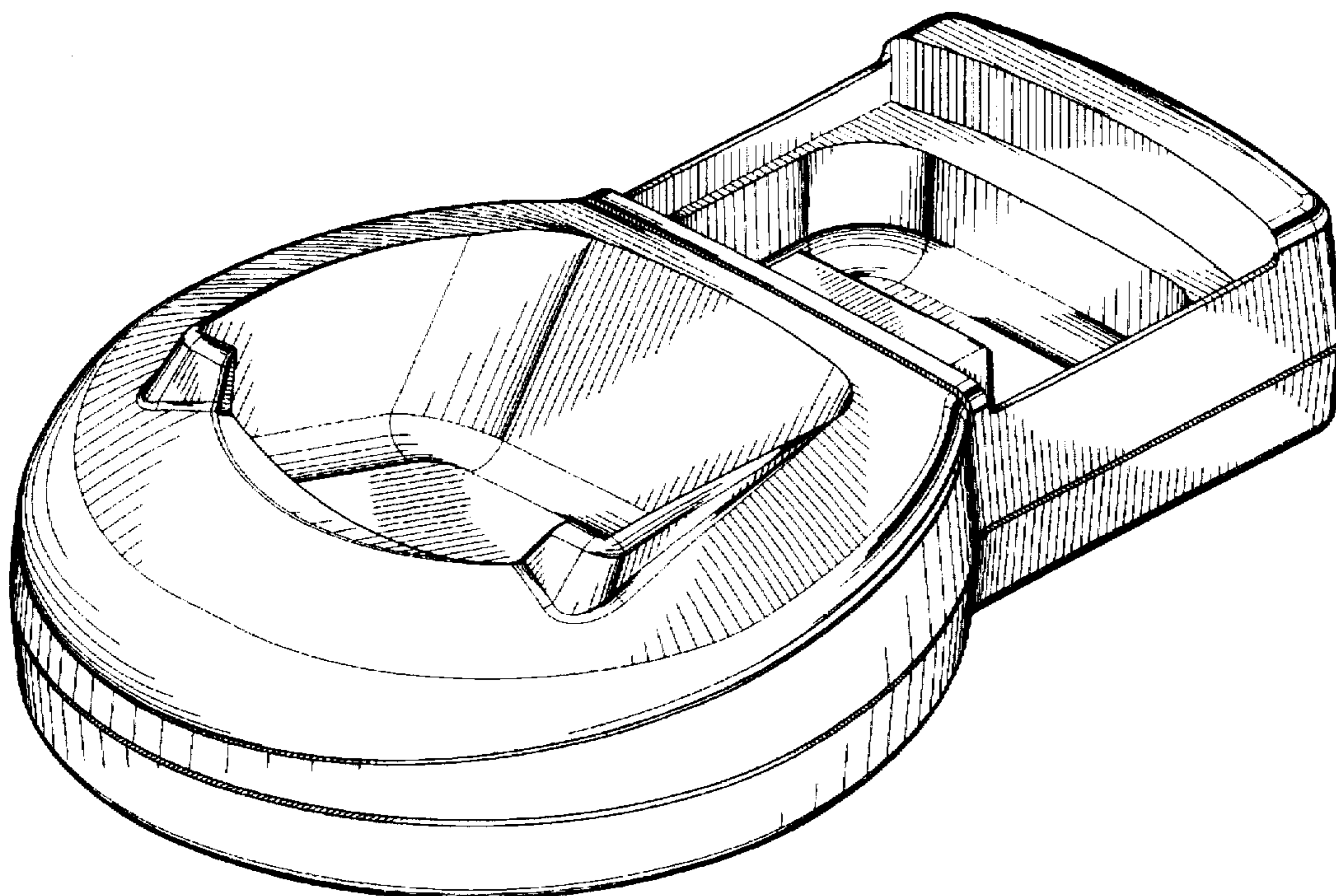

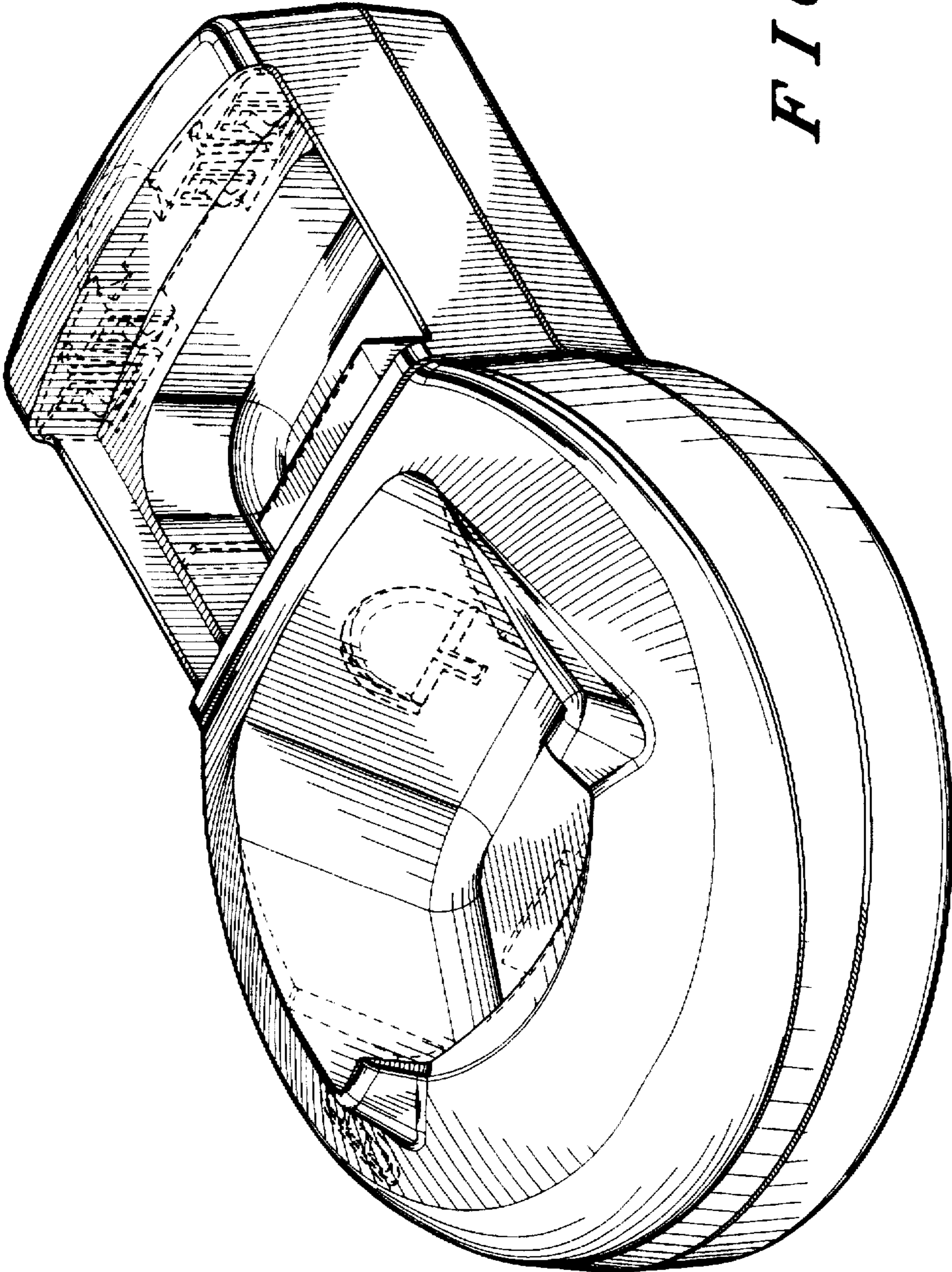

FIG. 1

FIG. 2

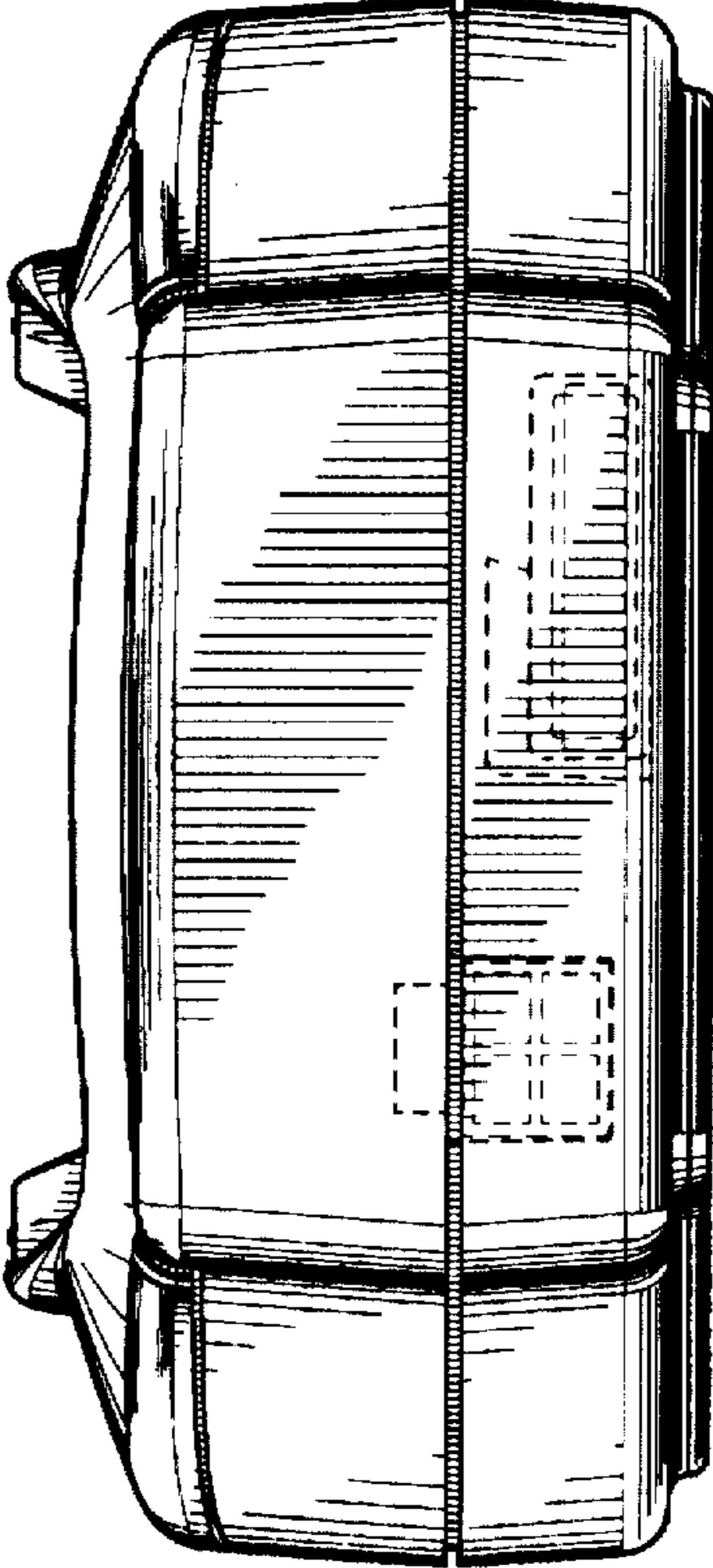
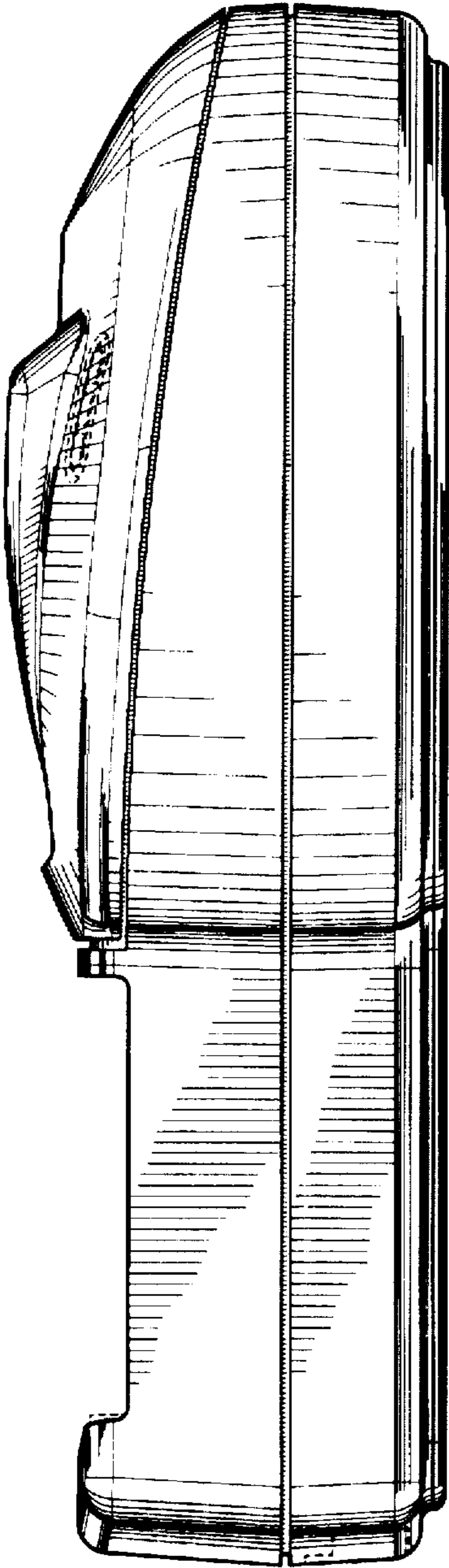

FIG. 3

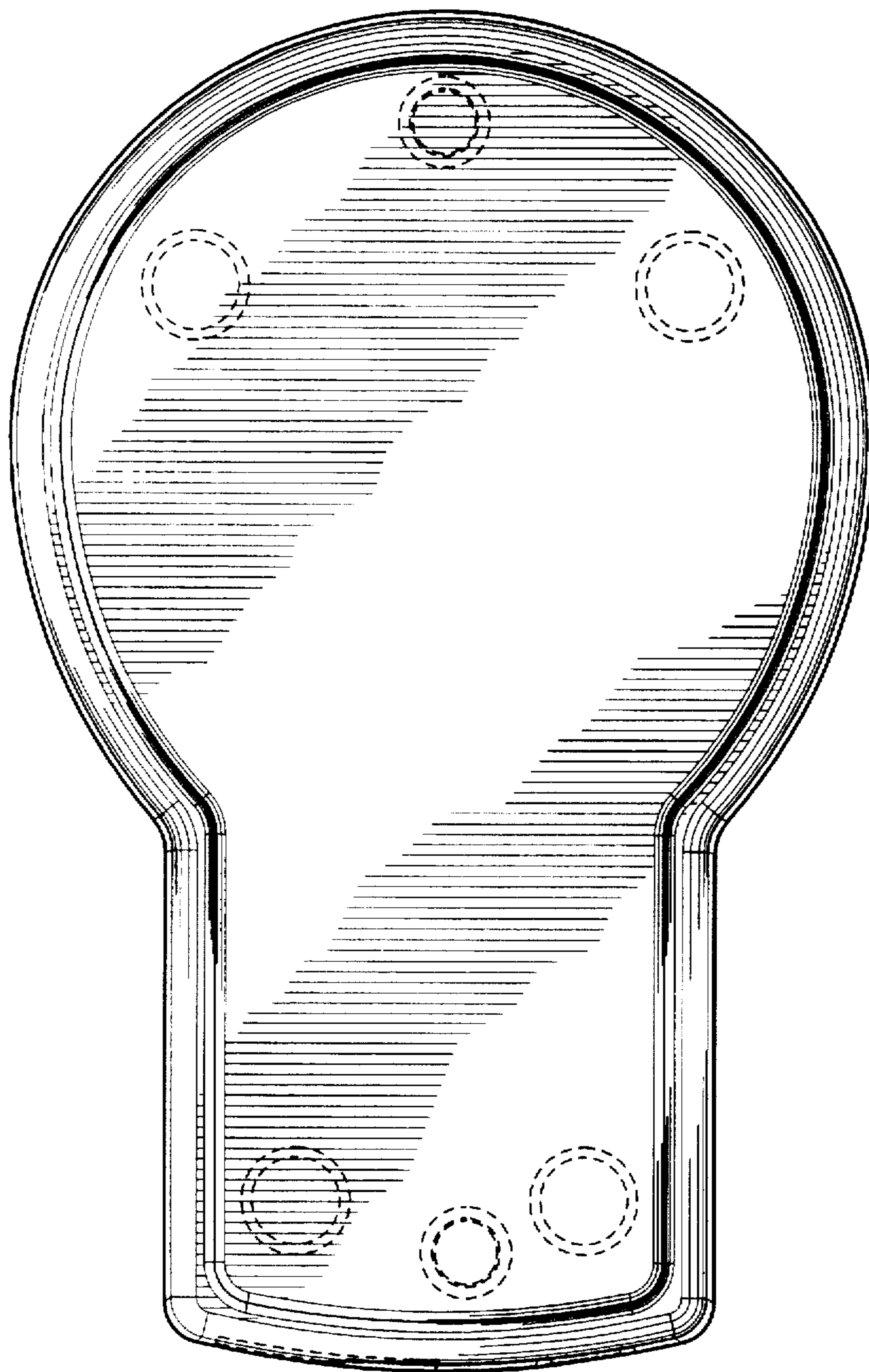

FIG. 4

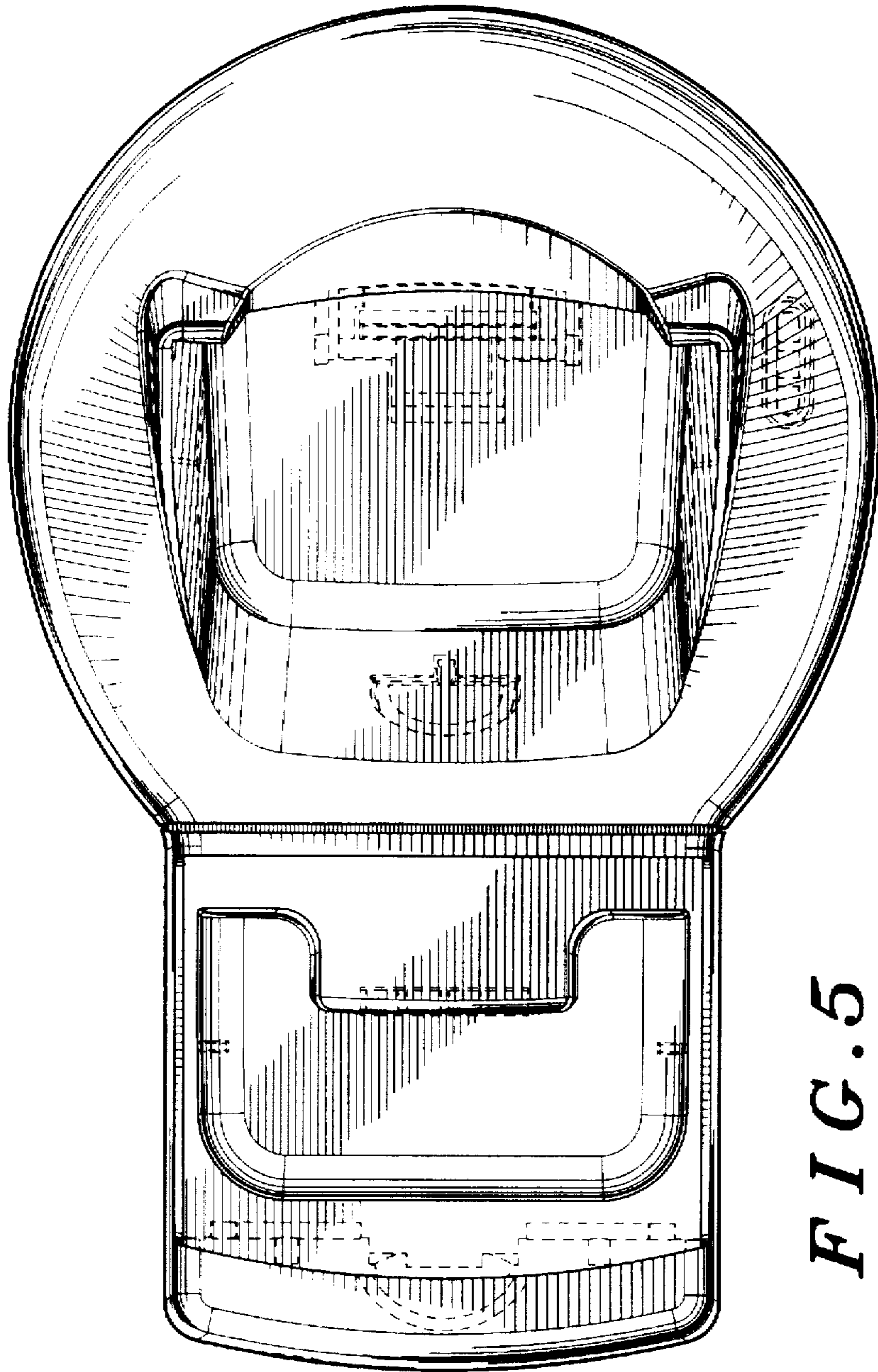

FIG. 5

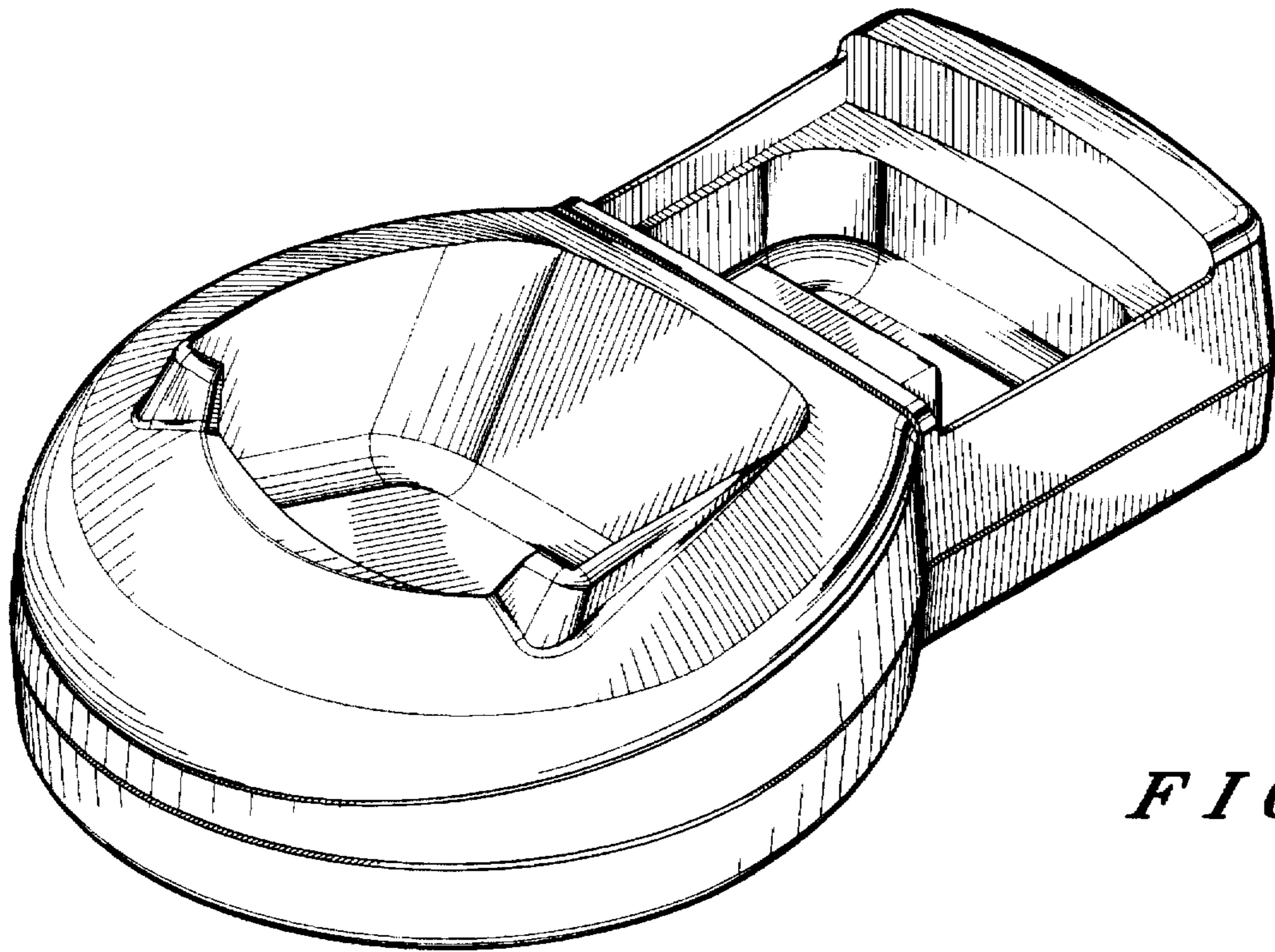

FIG. 6

FIG. 7

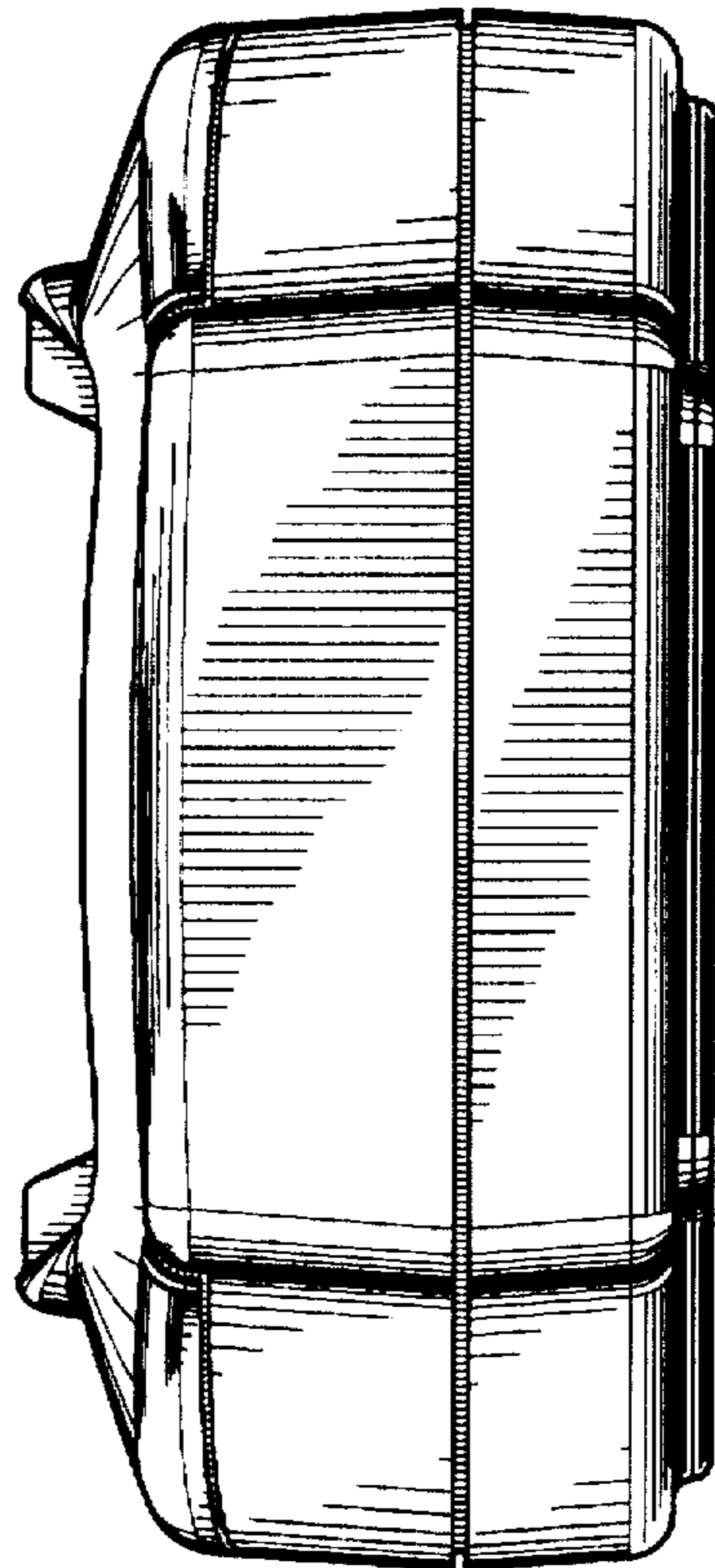
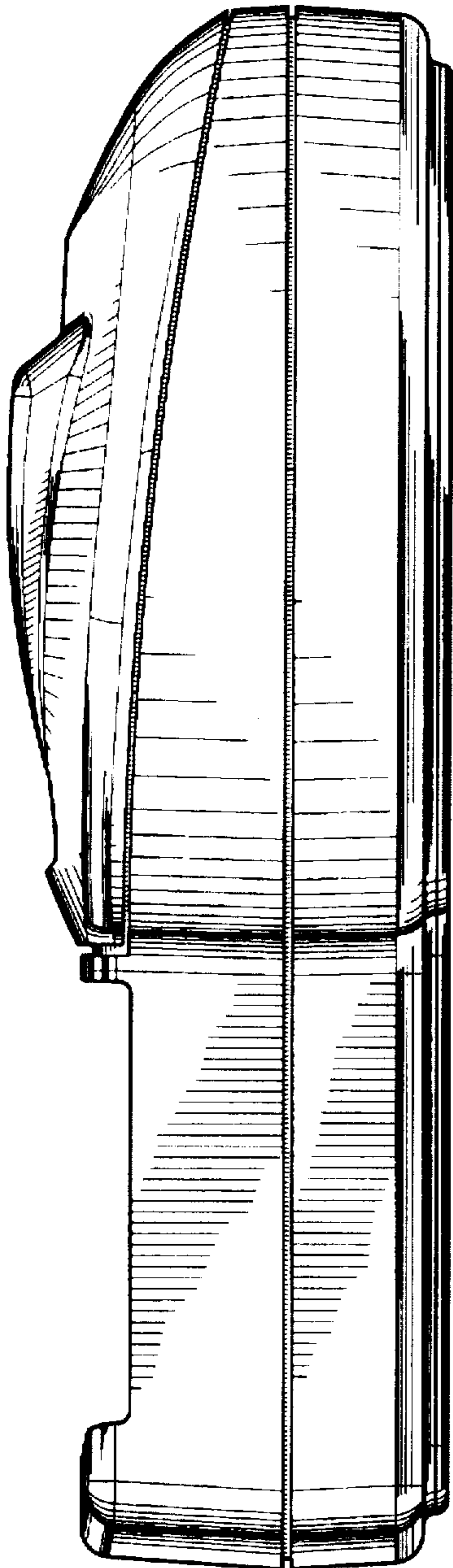

FIG. 8

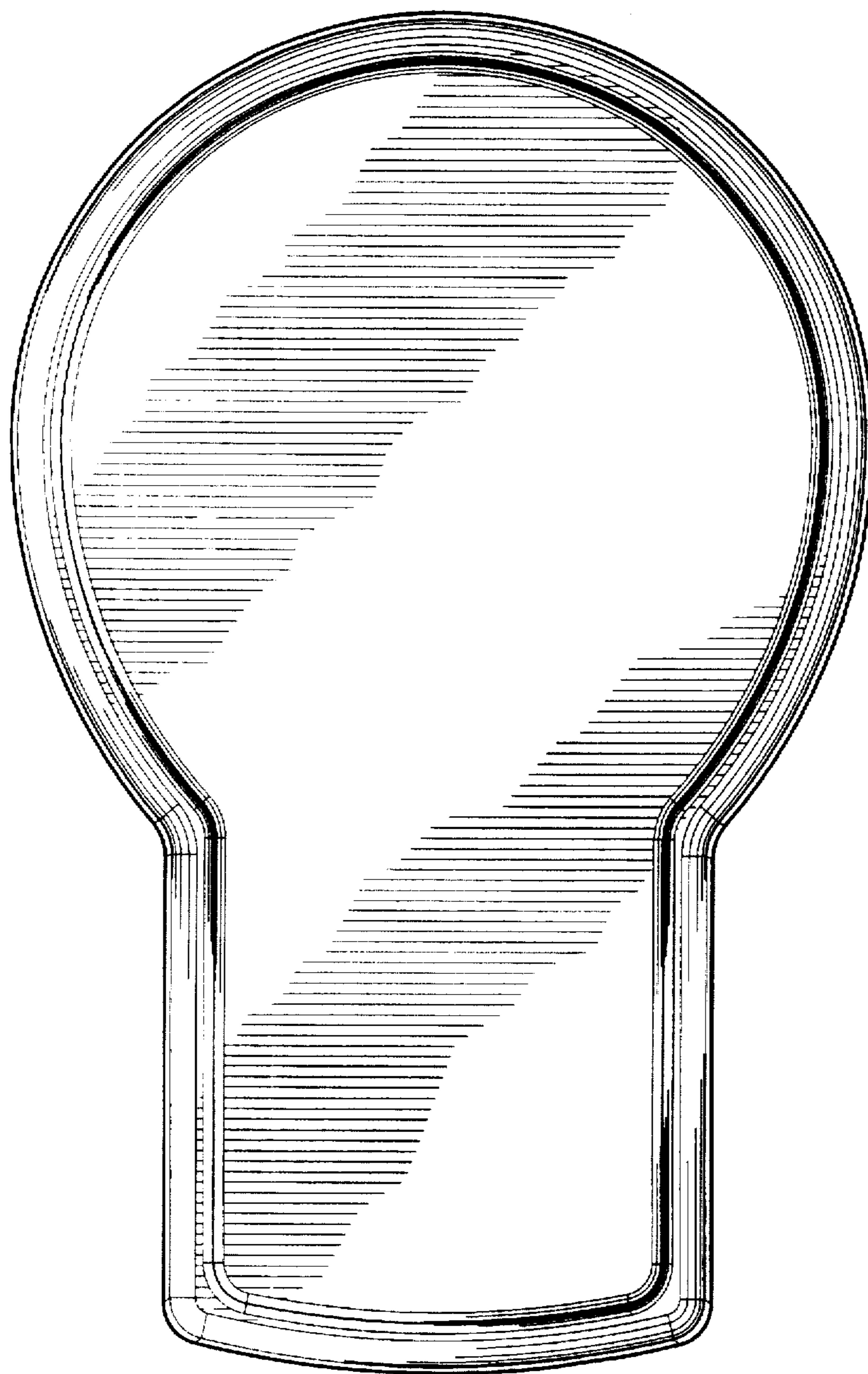

FIG. 9

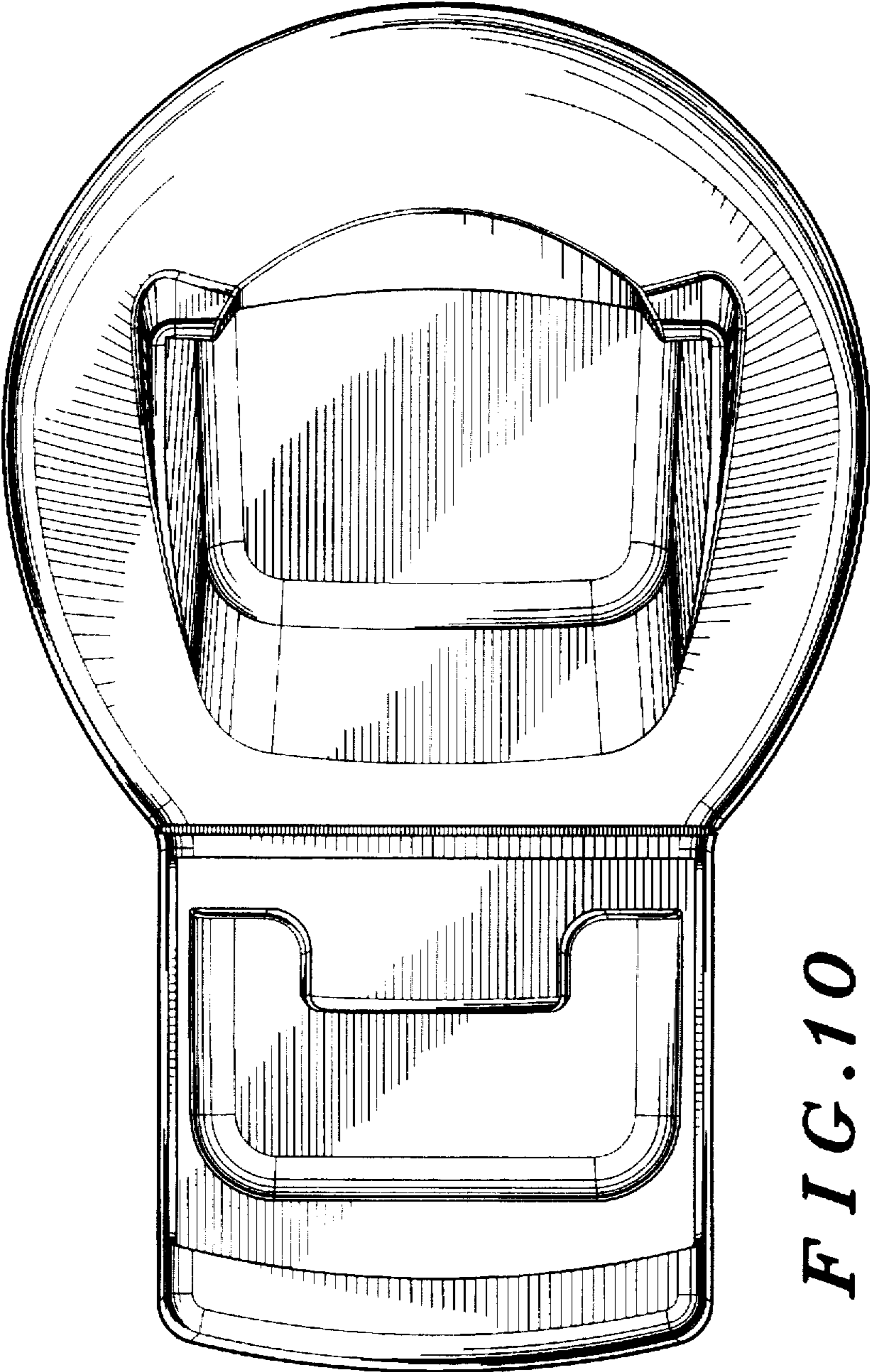

FIG. 10