



US00D394050S

**United States Patent** [19]  
**Funawatari**

[11] **Patent Number: Des. 394,050**

[45] **Date of Patent: \*\*May 5, 1998**

[54] **MAGNETIC DISC FOR COMPUTER**

[75] **Inventor: Takatsugu Funawatari, Tokyo, Japan**

[73] **Assignee: Sony Corporation, Tokyo, Japan**

[\*\*] **Term: 14 Years**

[21] **Appl. No.: 53,694**

[22] **Filed: Apr. 26, 1996**

[51] **LOC (6) Cl. .... 14-02**

[52] **U.S. Cl. .... D14/114**

[58] **Field of Search .... D14/114; 360/60, 360/132, 133, 135, 97.01, 99.12; 206/312**

[56] **References Cited**

**U.S. PATENT DOCUMENTS**

D. 325,468	4/1992	Ohba .....	D14/114
D. 339,798	9/1993	Tammert et al. ....	D14/114
D. 342,062	12/1993	Martin .....	D14/114
D. 350,115	8/1994	Iffikar et al. ....	D14/114

*Primary Examiner*—Kay H. Chin

*Attorney, Agent, or Firm*—Foley & Lardner

[57] **CLAIM**

The ornamental design for a magnetic disc for computer, as shown and described.

**DESCRIPTION**

FIG. 1 is a perspective view of a first embodiment of a

magnetic disc for computer showing my new design;

FIG. 2 is a perspective view thereof wherein the lid portion is in the open position;

FIG. 3 is a top plan view thereof;

FIG. 4 is a left side elevational view thereof;

FIG. 5 is a front elevational view thereof;

FIG. 6 is a bottom plan view thereof;

FIG. 7 is a right side elevational view thereof;

FIG. 8 is a rear elevational view thereof;

FIG. 9 is a perspective view of a second embodiment of a magnetic disc for computer showing my new design;

FIG. 10 is a perspective view of the embodiment of FIG. 9 wherein the lid portion is in the open position;

FIG. 11 is a top plan view of the embodiment of FIG. 9;

FIG. 12 is a left side elevational view of the embodiment of FIG. 9;

FIG. 13 is a front elevational view of the embodiment of FIG. 9;

FIG. 14 is a right side elevational view of the embodiment of FIG. 9; and,

FIG. 15 is a rear elevational view of the embodiment of FIG. 9;

A bottom plan view of the embodiment of FIG. 9 is shown in FIG. 6.

**1 Claim, 6 Drawing Sheets**

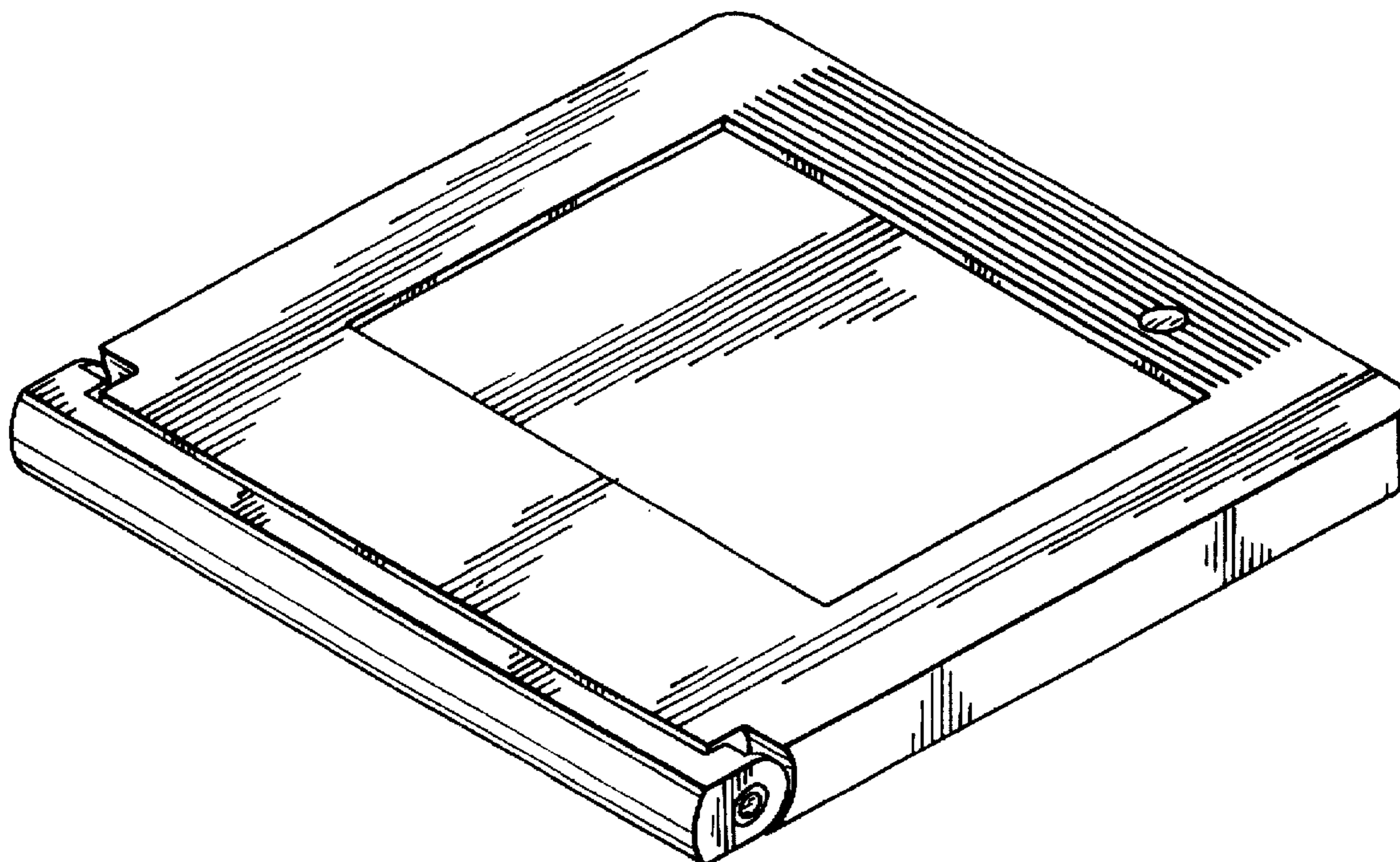

FIG. 1

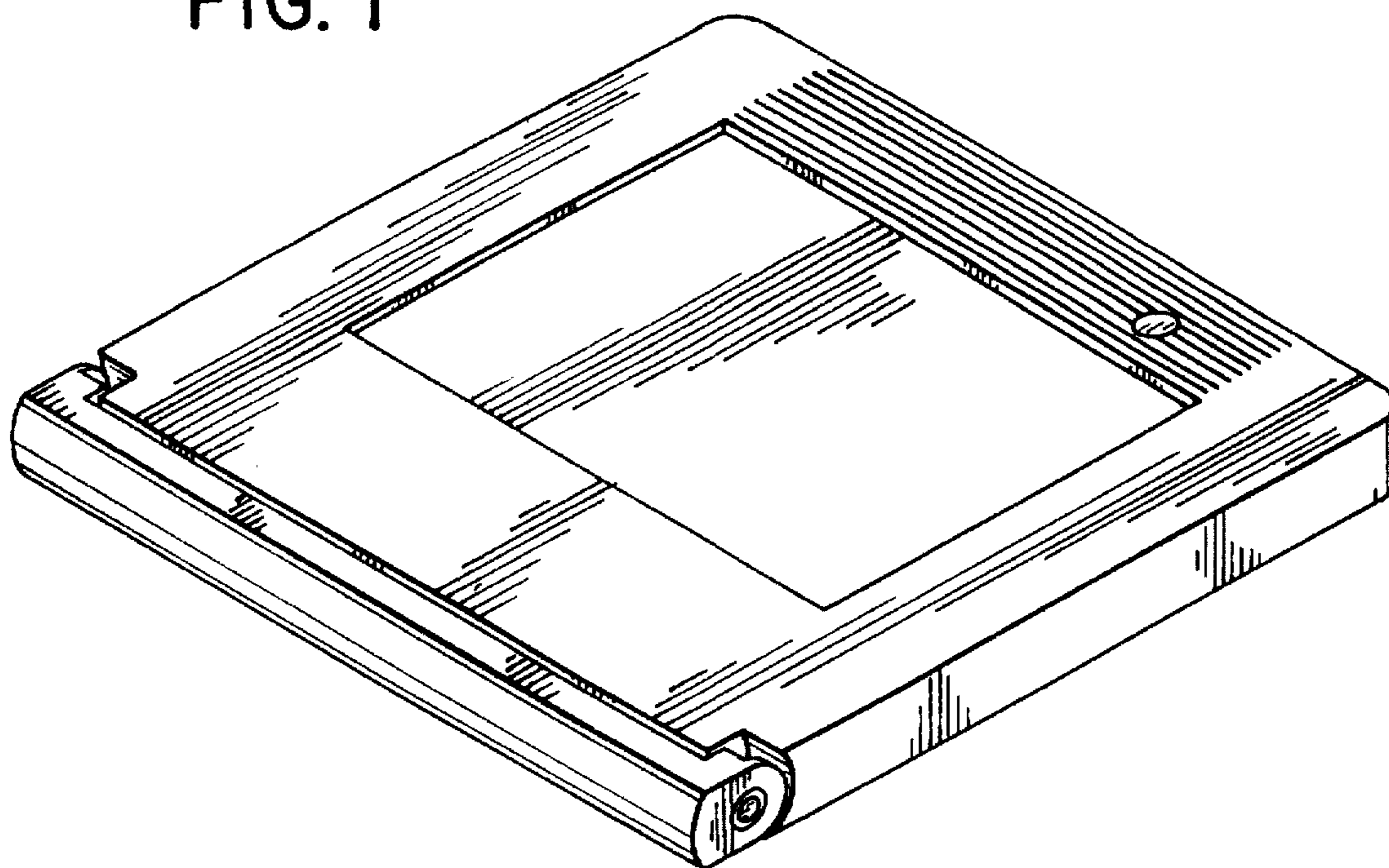

FIG. 2

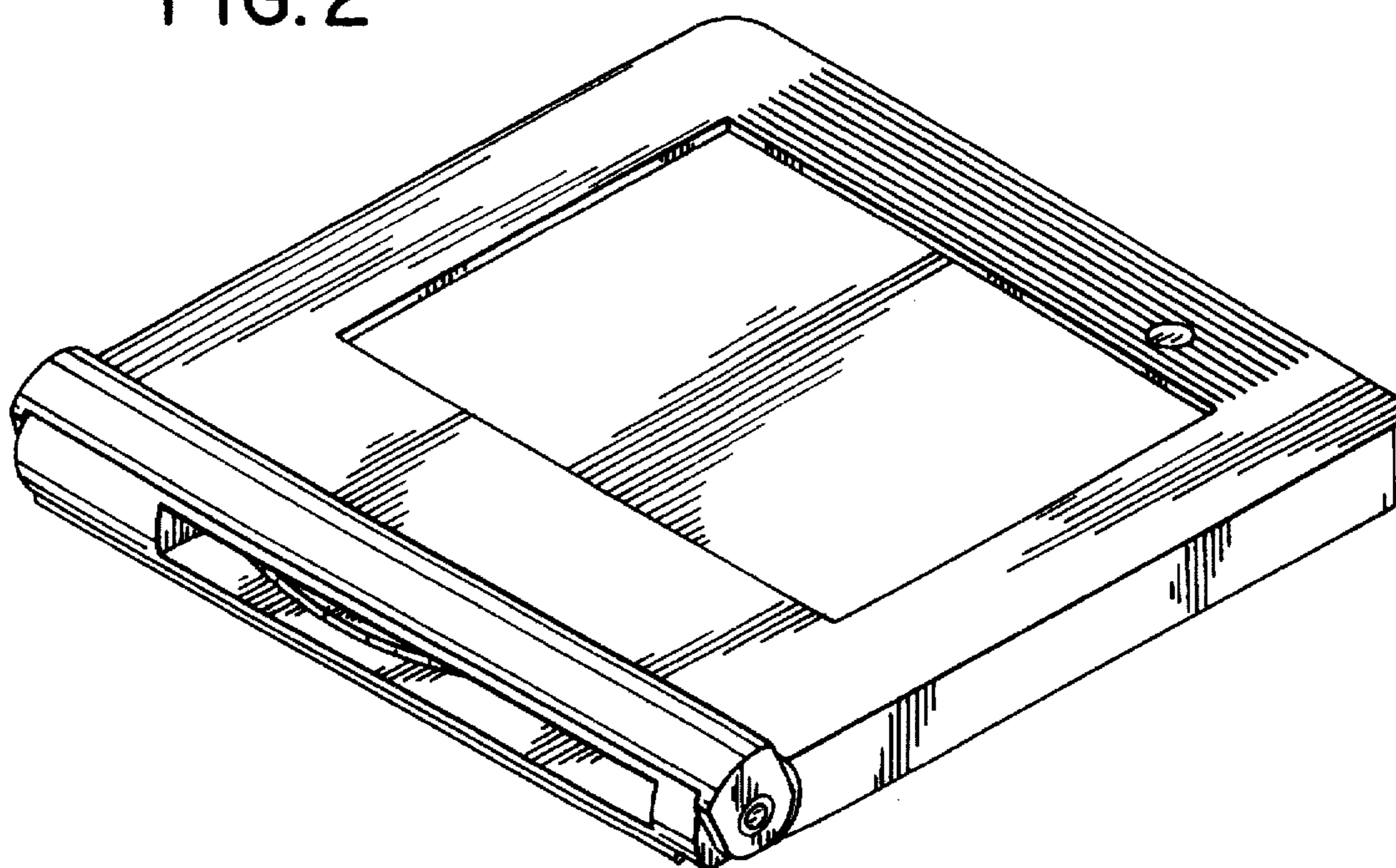

FIG. 3



FIG. 5

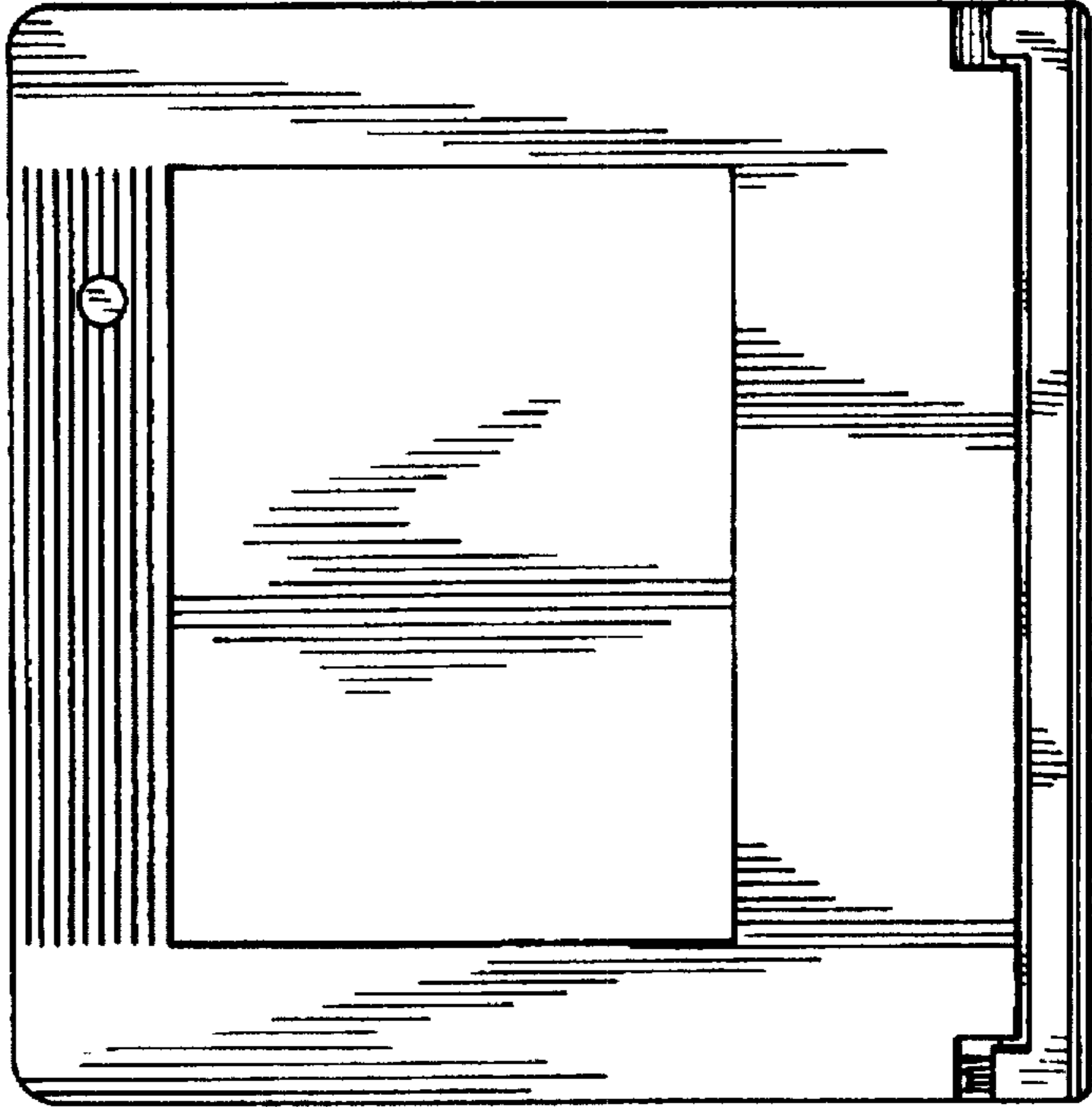

FIG. 4



FIG. 6

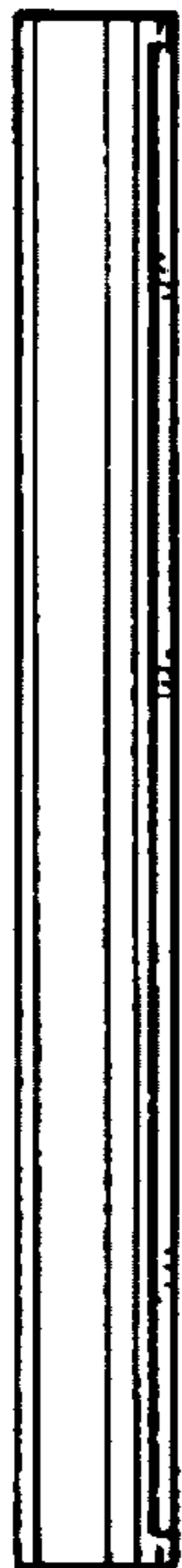

FIG. 7

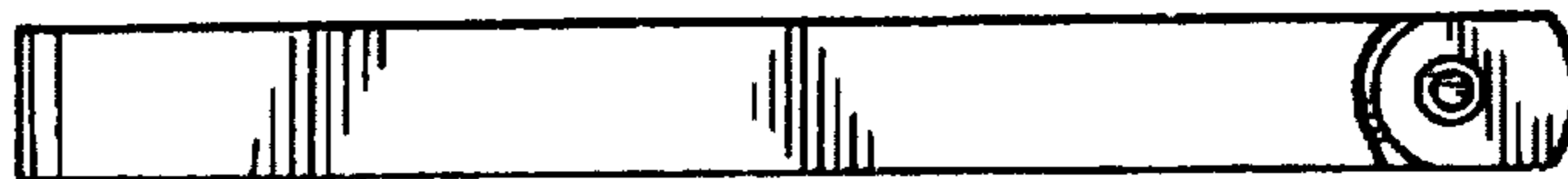

FIG. 8

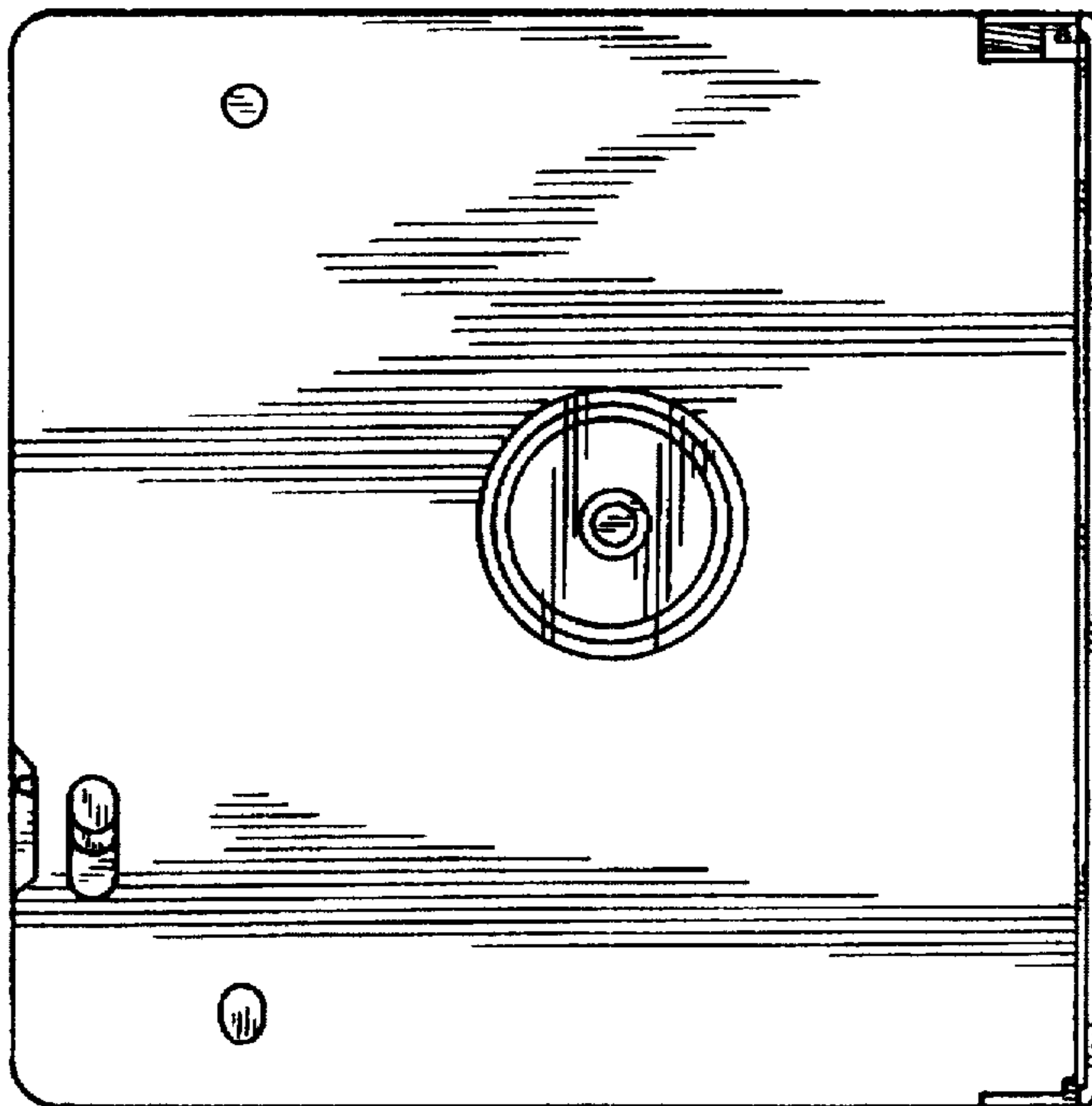

FIG. 9

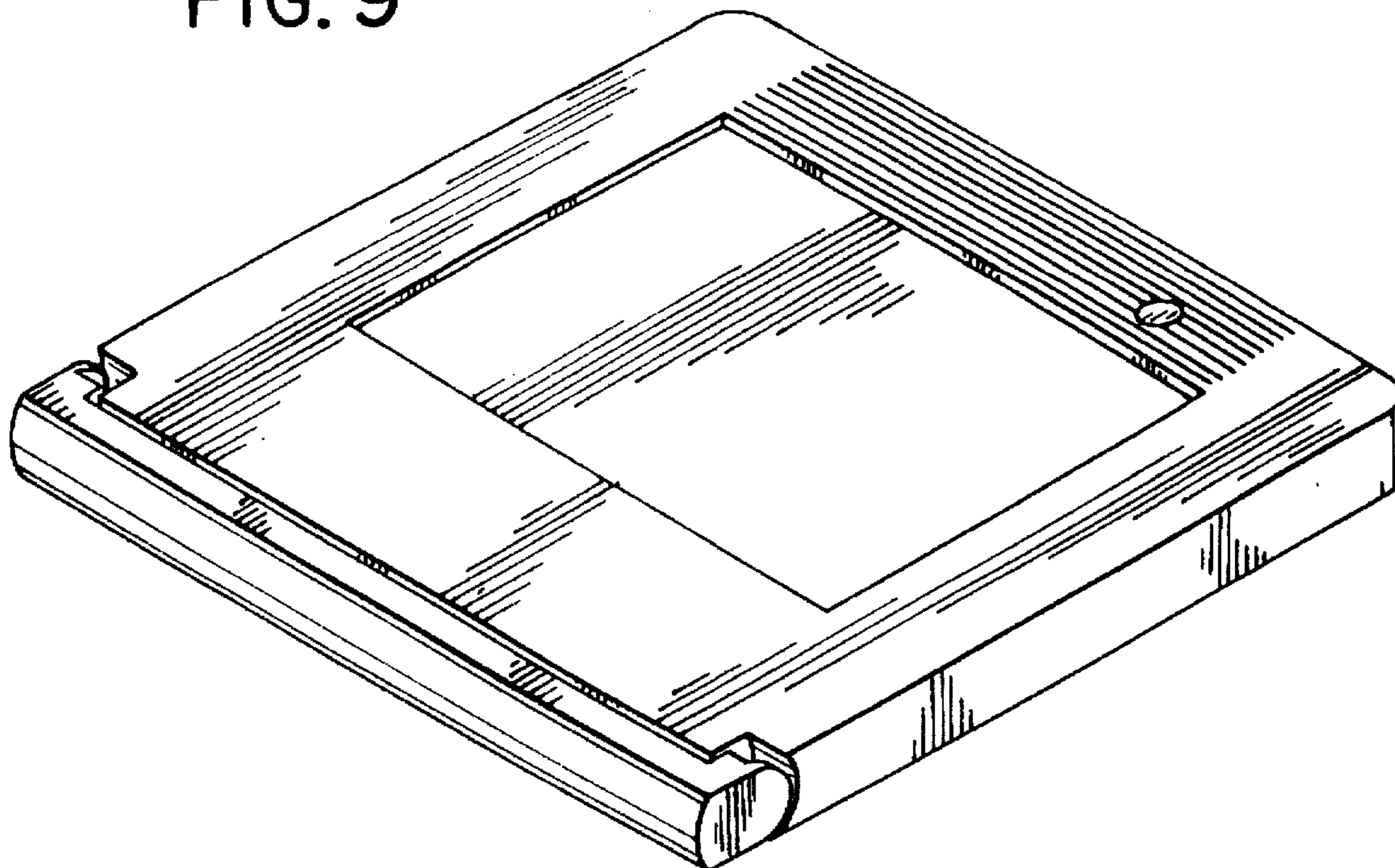

FIG. 10

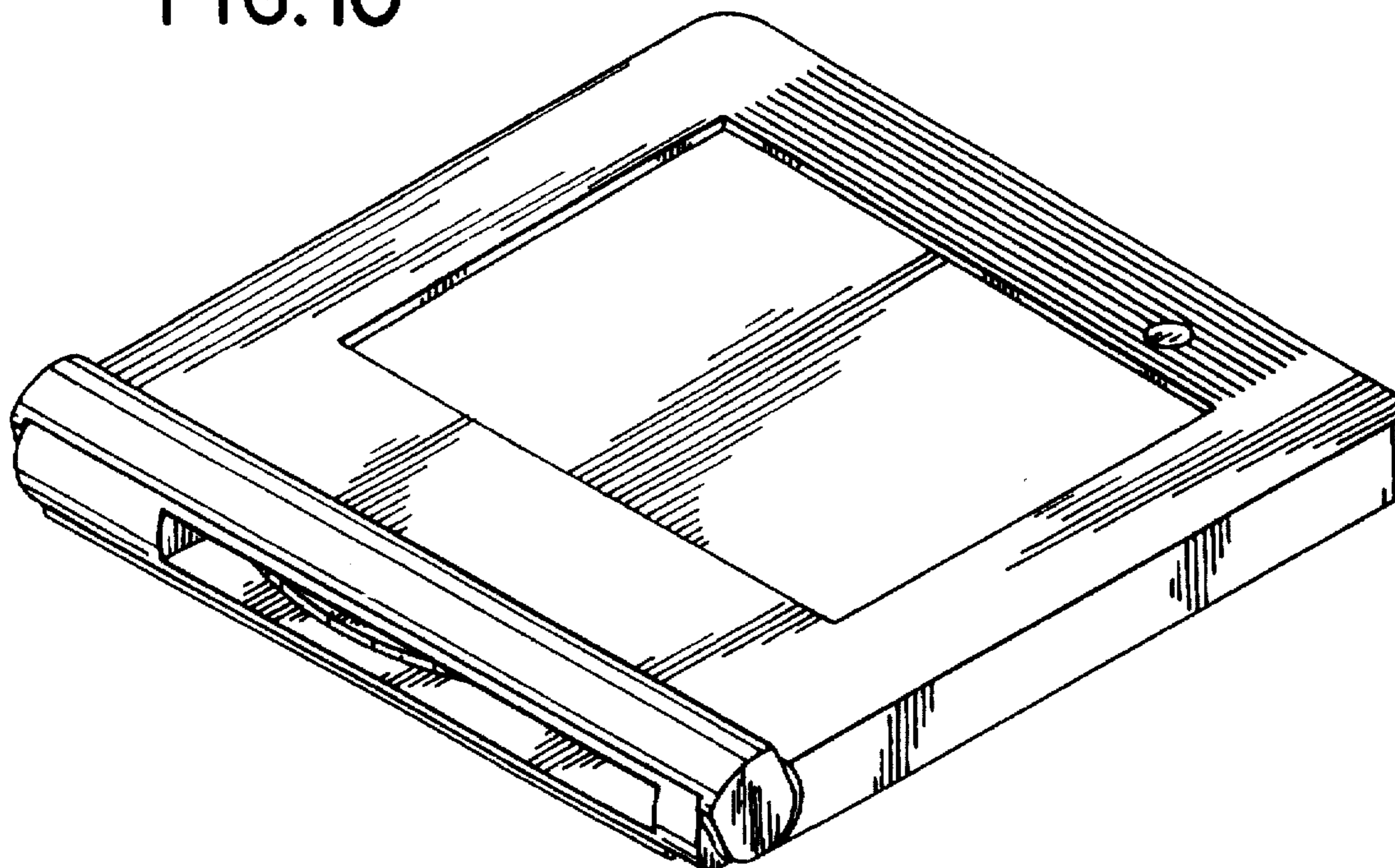

FIG. 11



FIG. 13

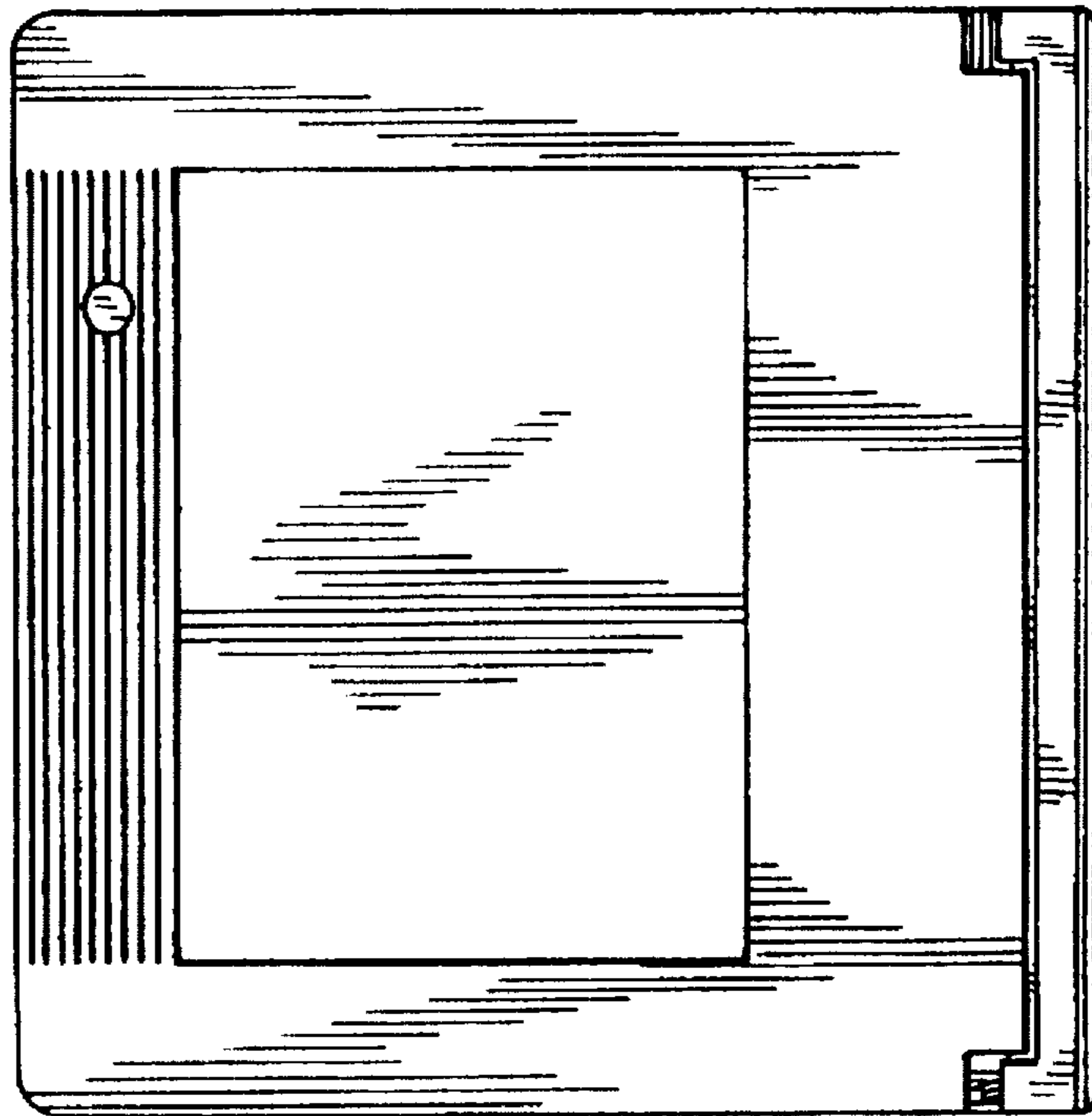

FIG. 12



FIG. 15

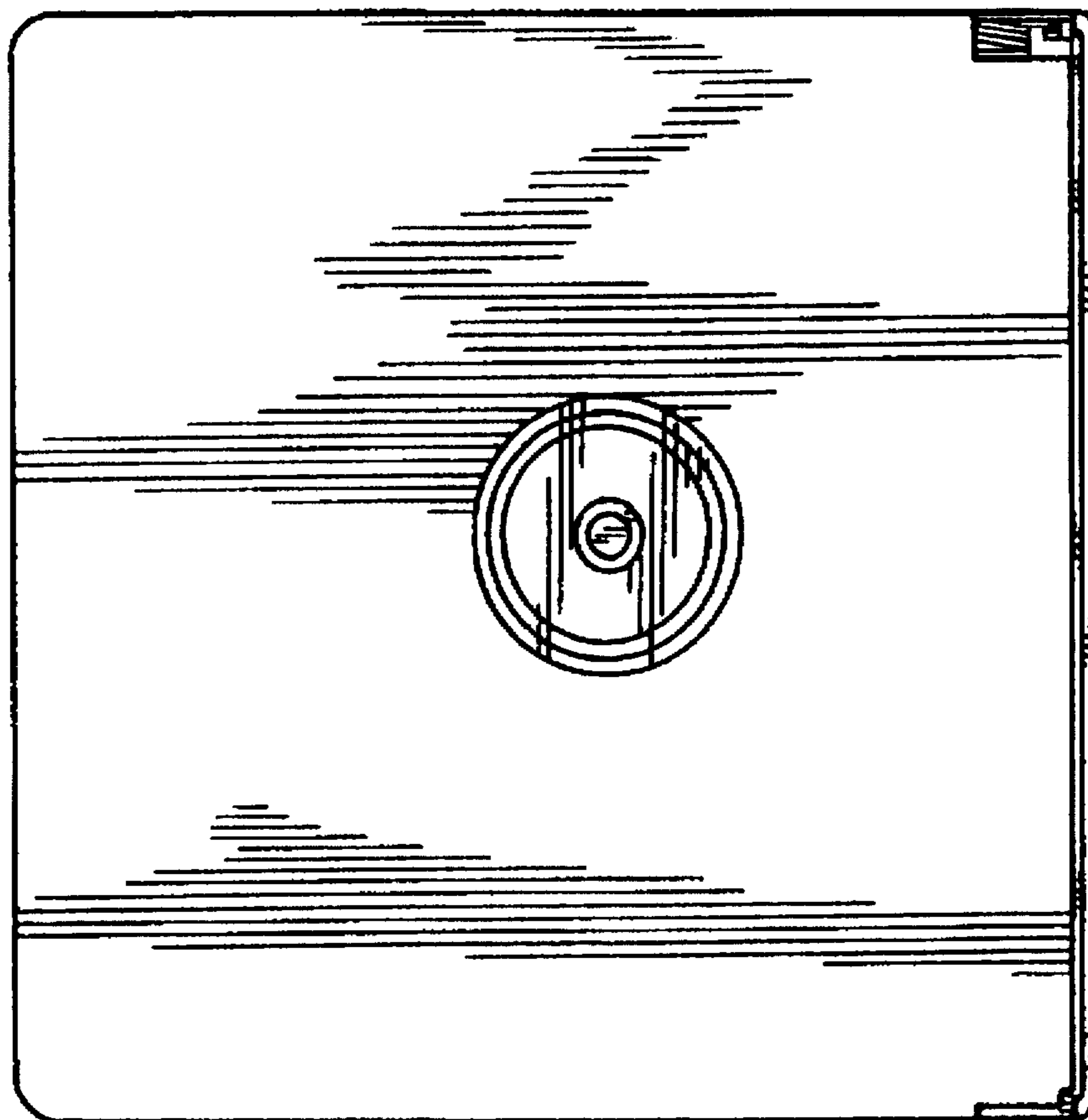

FIG. 14

