

US00D394039S

# United States Patent [19] Cummings

[11] Patent Number: **Des. 394,039**

[45] Date of Patent: **\*\*May 5, 1998**

[54] AIRPLANE

D. 372,218 7/1996 Herzberg et al. .... D12/333

[75] Inventor: **Darold B. Cummings**, Hawthorne, Calif.

*Primary Examiner*—Kay H. Chin  
*Attorney, Agent, or Firm*—Charles T. Silberberg; Lawrence N. Ginsberg

[73] Assignee: **Boeing North American, Inc.**, Seal Beach, Calif.

[57] **CLAIM**

[\*\*] Term: **14 Years**

The ornamental design for an airplane, as shown.

[21] Appl. No.: **72,587**

**DESCRIPTION**

[22] Filed: **Jun. 23, 1997**

FIG. 1 is a top, front, left side elevational view of an airplane showing my new design;

[51] LOC (6) Cl. .... **12-07**

FIG. 2 is a top plan view thereof;

[52] U.S. Cl. .... **D12/333; D12/319**

FIG. 3 is a front elevational view thereof;

[58] Field of Search ..... **D12/319-345; 244/215, 45 A. 45 R. 15**

FIG. 4 is a left side elevational view thereof;

FIG. 5 is a bottom, front, left side elevational view thereof;

FIG. 6 is a bottom plan view thereof;

FIG. 7 is a rear elevational view thereof; and,

FIG. 8 is a right side elevational view thereof.

[56] **References Cited**

**U.S. PATENT DOCUMENTS**

D. 342,717 12/1993 Mrdeza et al. .... D12/333

**1 Claim, 3 Drawing Sheets**

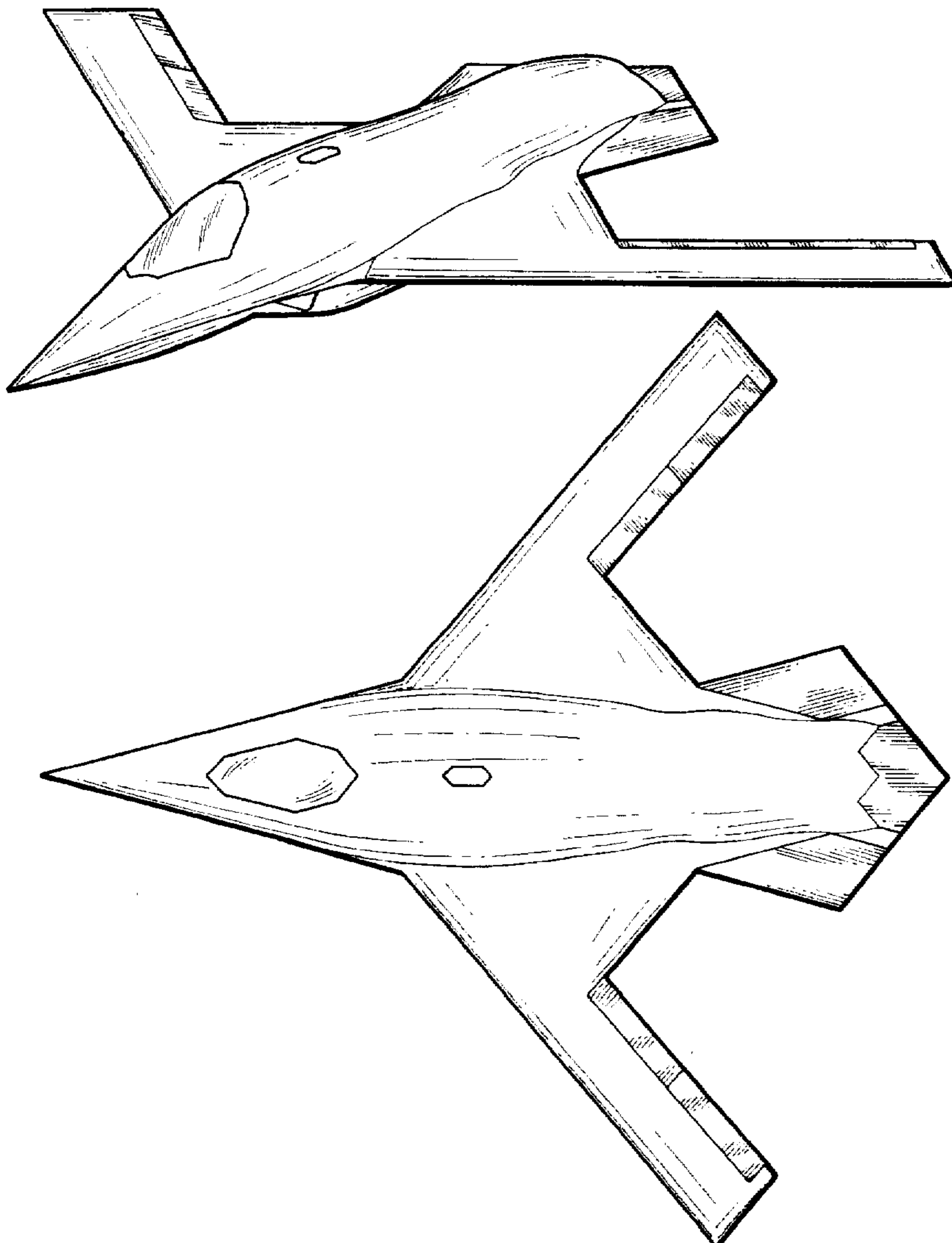

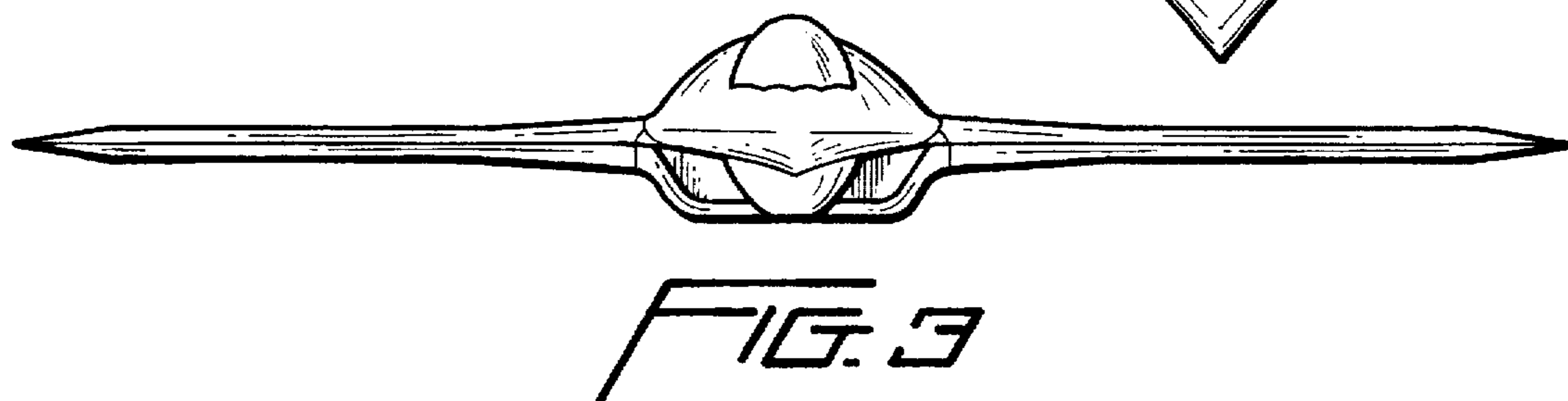
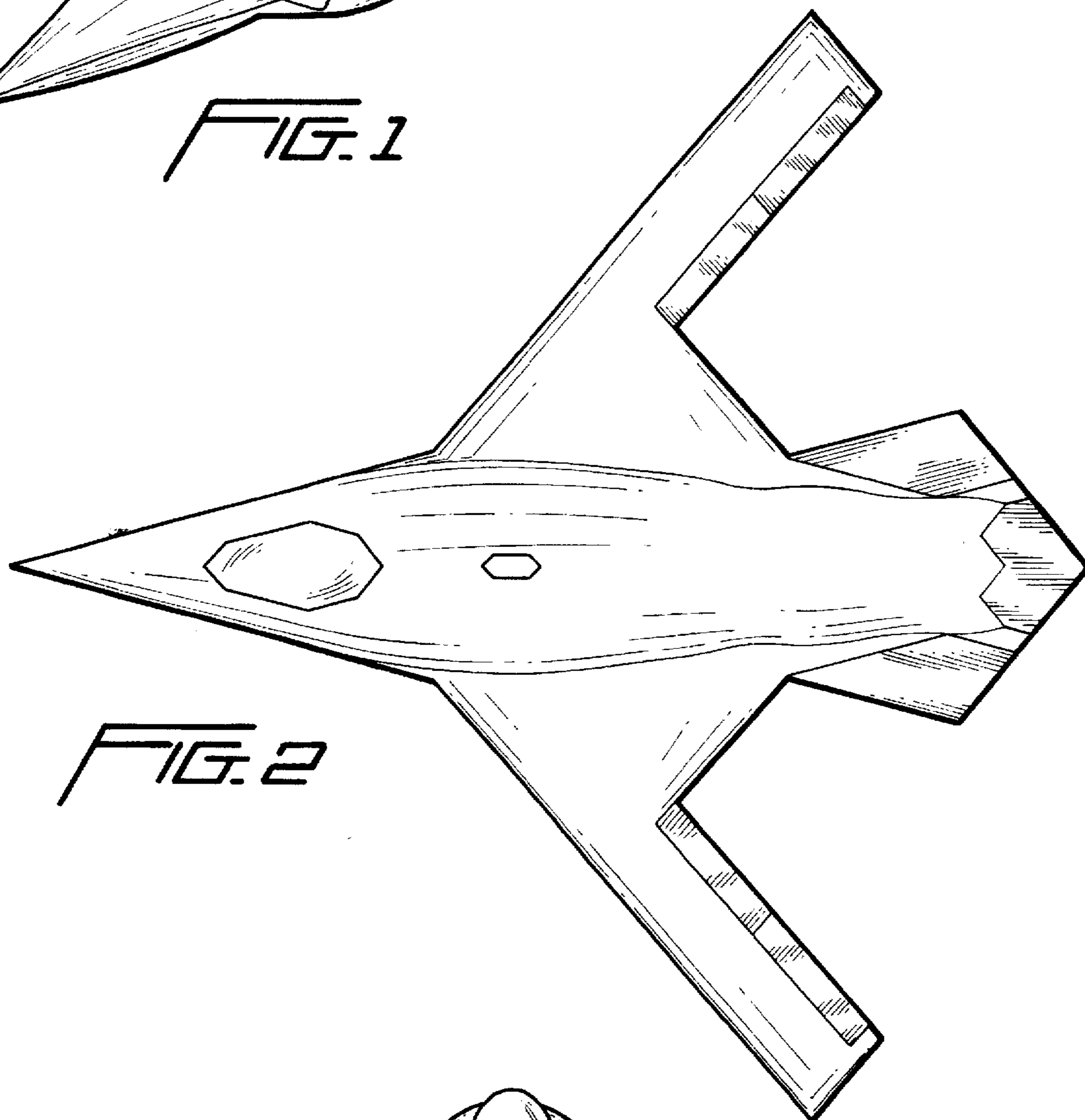
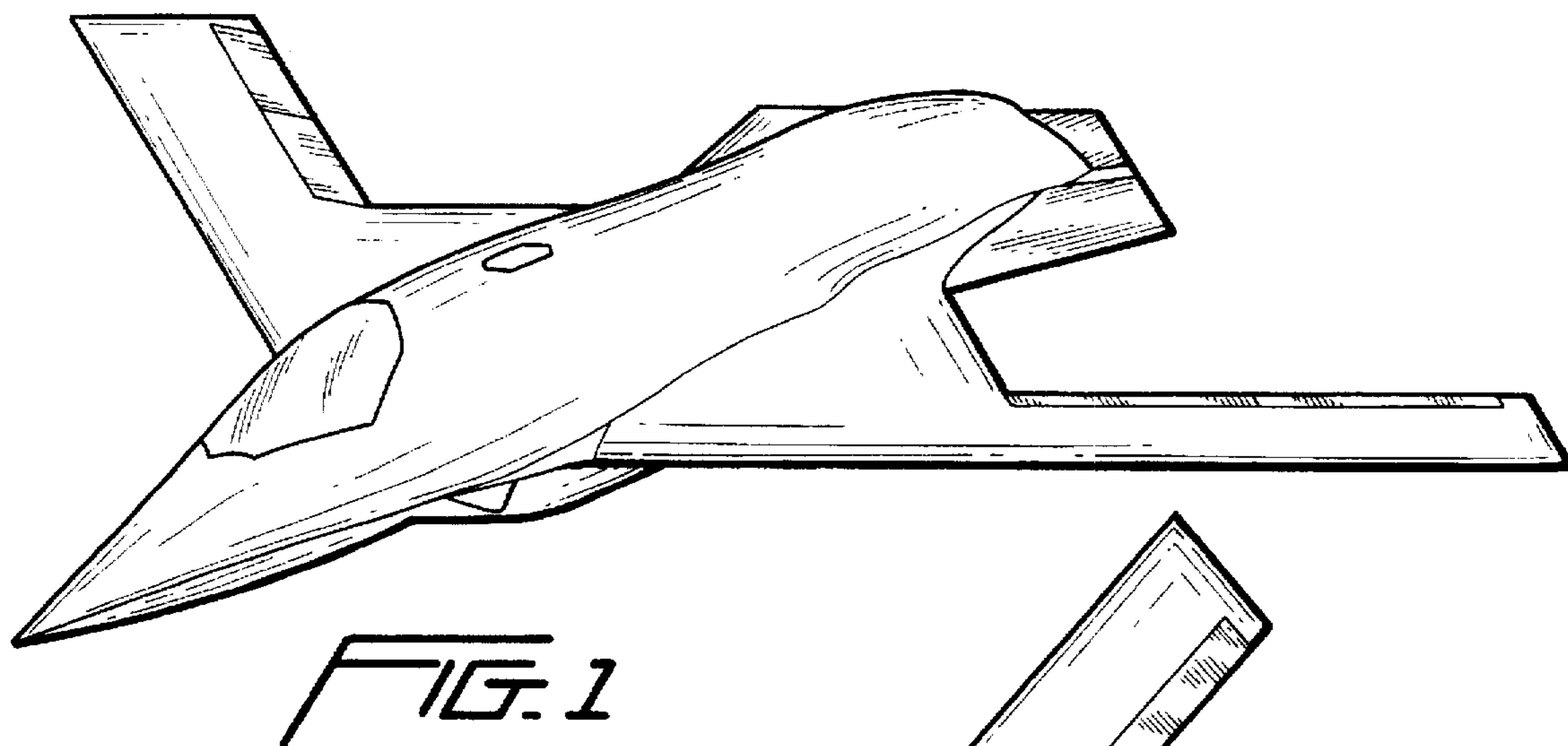

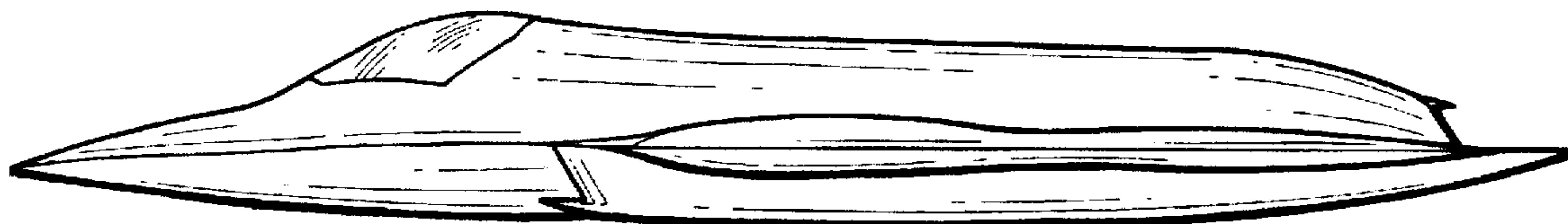

FIG. 4

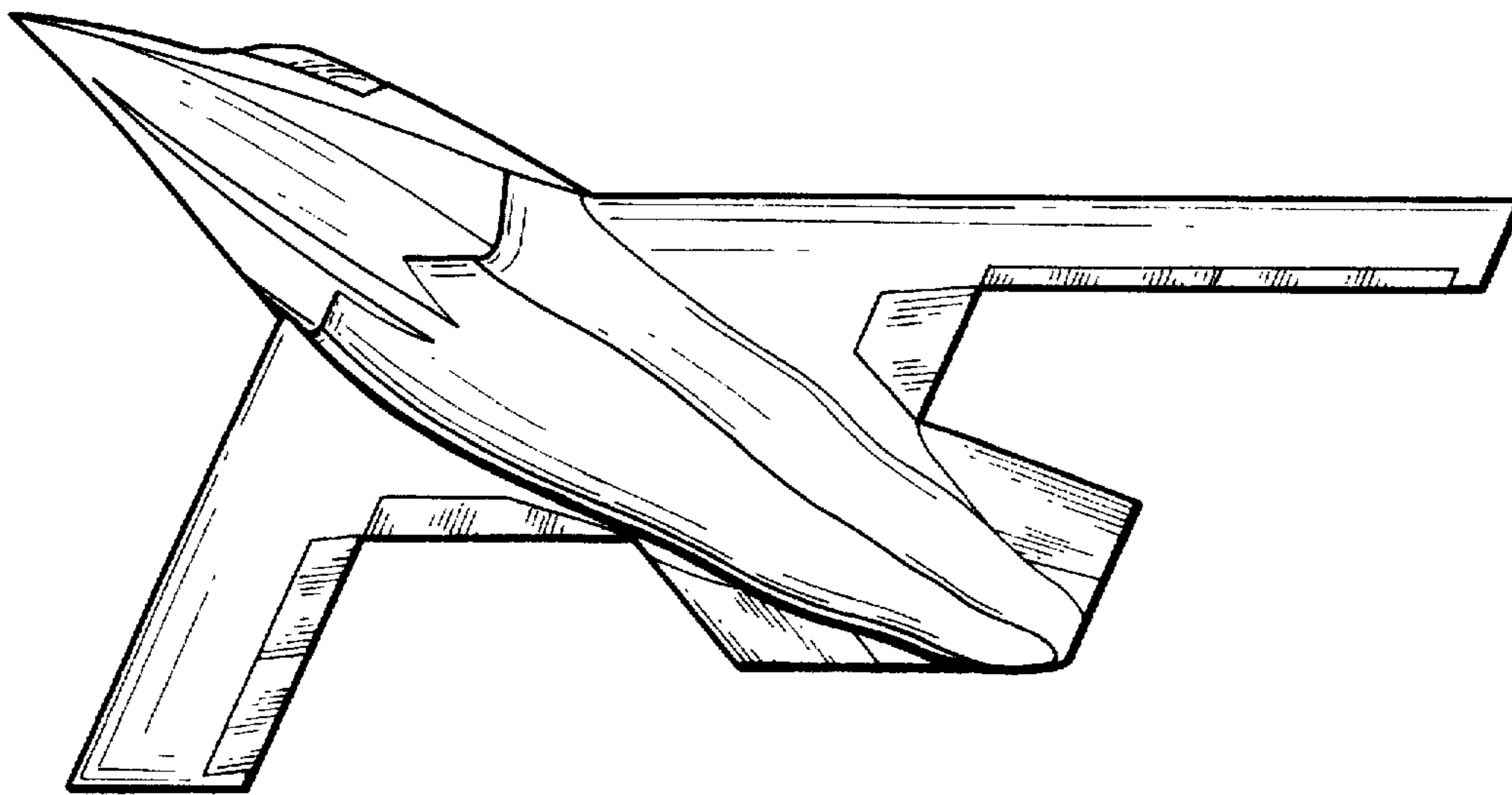

FIG. 5

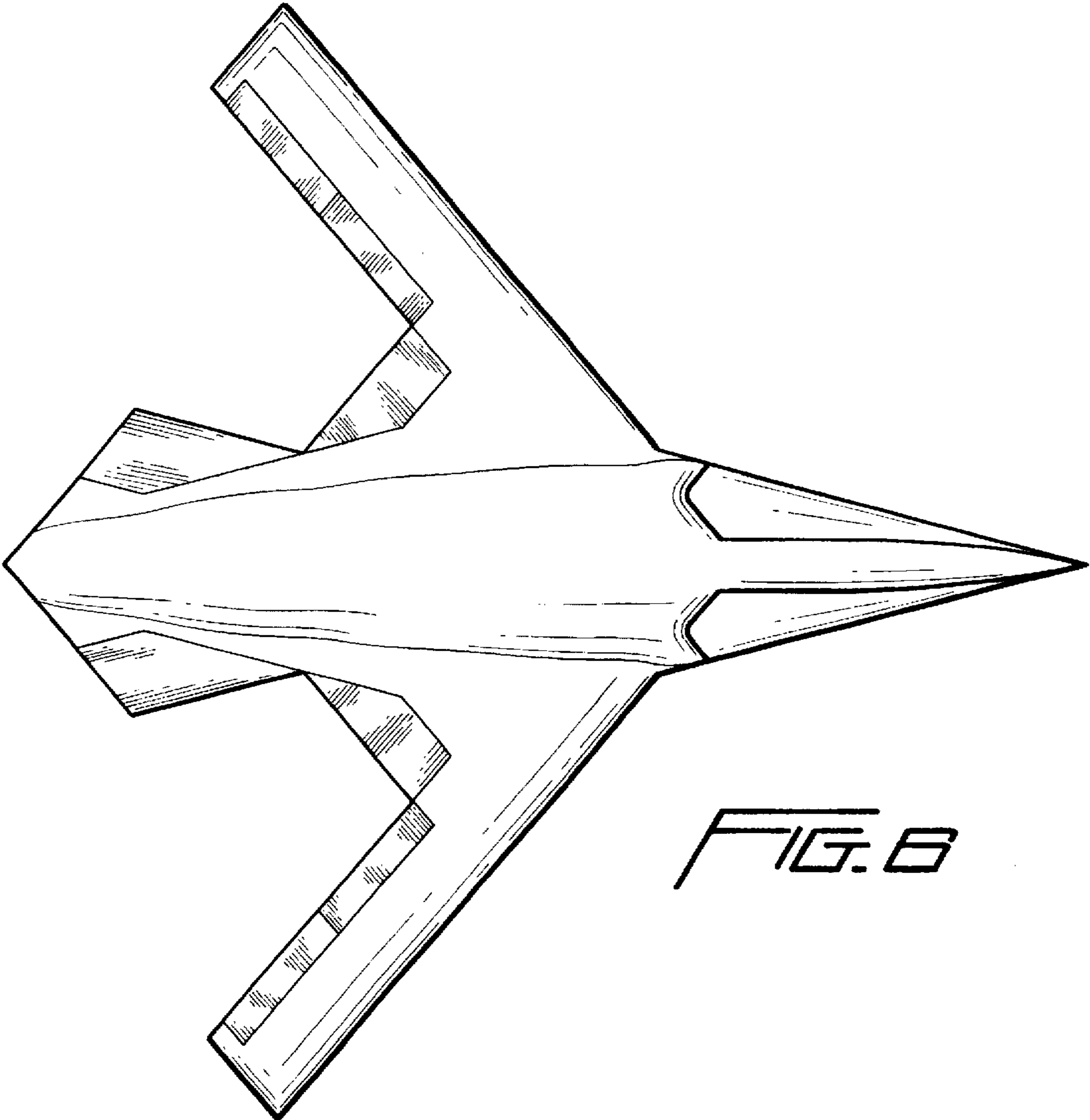

FIG. 6

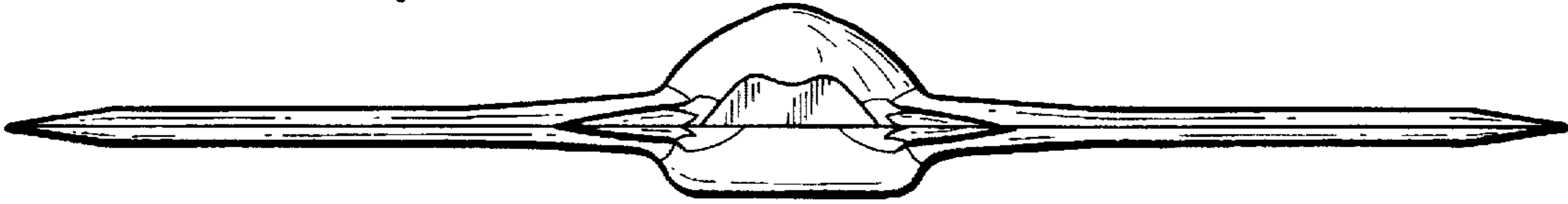

FIG. 7

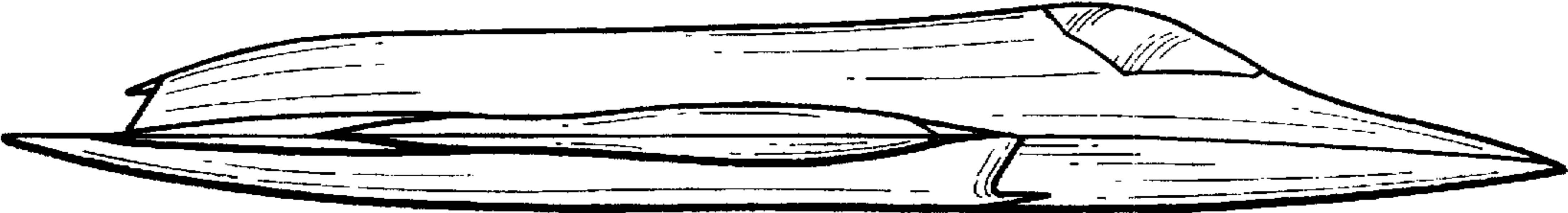

FIG. 8