

US00D394035S

United States Patent [19]

Stosel et al.

[11] Patent Number: Des. 394,035

[45] Date of Patent: **May 5, 1998

- [54] **VEHICLE AIR INTAKE GRILLE**
- [75] Inventors: **Dennis E. Stosel**, Kernersville; **Thomas J. Palenchar**, Greensboro, both of N.C.
- [73] Assignee: **Volvo GM Heavy Truck Corporation**, Greensboro, N.C.
- [**] Term: **14 Years**
- [21] Appl. No.: **59,127**
- [22] Filed: **Aug. 16, 1996**
- [51] LOC (6) Cl. **12-16**
- [52] U.S. Cl. **D12/163**
- [58] Field of Search **D12/163, 183, D12/196; 55/385.3; 180/68.1, 68.3, 68.6, 69.2, 69.21; 123/198.5**

4,689,060	8/1987	Koske	55/385.3
4,850,444	7/1989	Bojunowski et al.	180/68.1
4,878,555	11/1989	Yasunaga et al.	180/68.3
4,917,202	4/1990	Glover, Jr. et al.	180/68.3
4,971,172	11/1990	Hoffman et al.	180/68.3
5,022,479	6/1991	Kiser et al.	180/68.3
5,034,036	7/1991	Creek et al.	55/385.3
5,120,344	6/1992	Cooper	106/900
5,152,365	10/1992	Aoshima	180/68.3
5,174,258	12/1992	Tanaka	123/198 E
5,195,484	3/1993	Knapp	123/198 E

Primary Examiner—Melody N. Brown
Attorney, Agent, or Firm—Watts, Hoffmann, Fisher & Heinke Co., L.P.A.

[57] CLAIM

The ornamental design for an vehicle air intake grille, as shown and described.

DESCRIPTION

FIG. 1 is a perspective view of an vehicle air intake grille showing our new design, the portions of the truck shown in broken lines are for illustrative purposes only and form no part of the claimed design;
 FIG. 2 is a front elevational view thereof;
 FIG. 3 is a rear elevational view thereof;
 FIG. 4 is a top plan view thereof, taken from line 4—4 of FIG. 2;
 FIG. 5 is a bottom plan view thereof, taken from line 5—5 of FIG. 2;
 FIG. 6 is a side elevational view thereof, taken from line 6—6 of FIG. 2; and,
 FIG. 7 is an opposite side elevational view thereof, taken line 7—7 of FIG. 2.

[56] References Cited

U.S. PATENT DOCUMENTS

D. 355,880	2/1995	Roberto	D12/183
D. 367,027	2/1996	Onopu	D12/173
1,855,038	4/1932	Walker	180/68.3
1,863,015	6/1932	Kamrath	180/68.3
3,232,368	2/1966	Sullivan	180/68.3
4,133,547	1/1979	Fox	180/68.3
4,157,902	6/1979	Tokar	55/385.3
4,159,899	7/1979	Deschenes	55/454
4,208,197	6/1980	Yakimowich et al.	55/315
4,212,659	7/1980	Magrubu	55/385.3
4,440,555	4/1984	Chichester	55/385.3
4,454,926	6/1984	Akins	180/68.1
4,516,680	5/1985	Yamaguchi et al.	180/68.3
4,606,422	8/1986	Jewett	180/68.1
4,648,684	3/1987	Racchi	180/69.22
4,681,178	7/1987	Brown	180/68.3

1 Claim, 3 Drawing Sheets

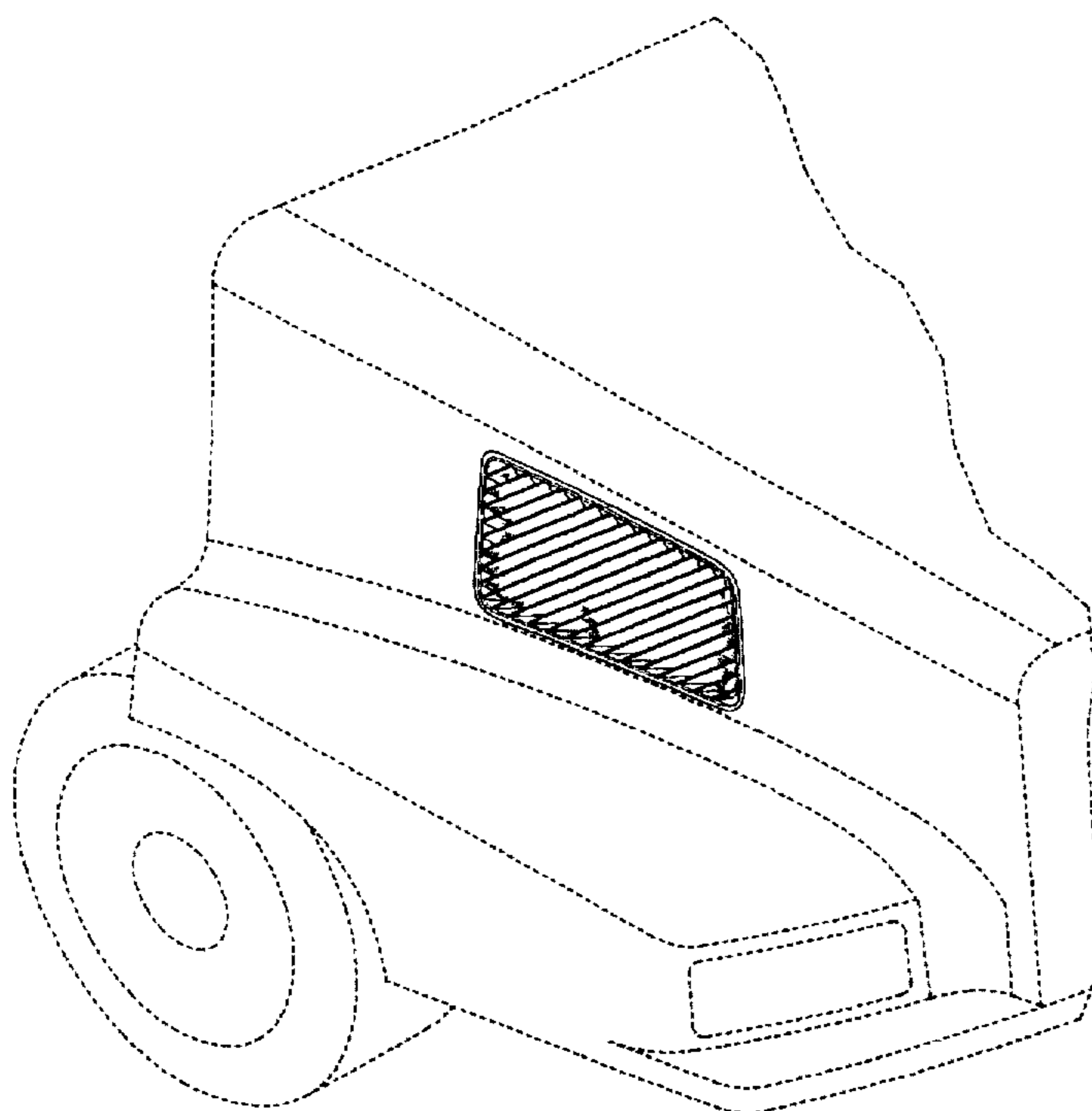

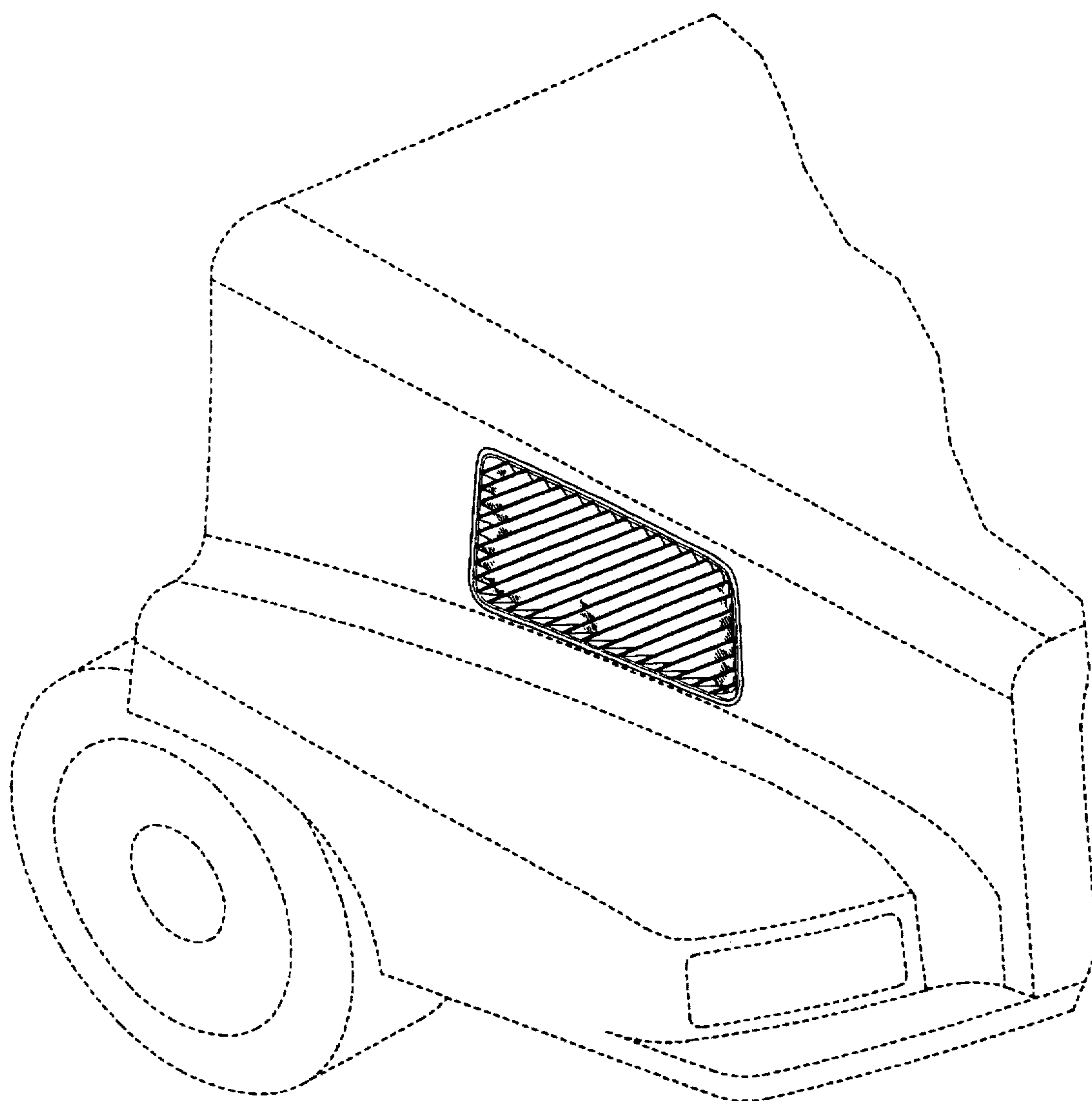

Fig.1

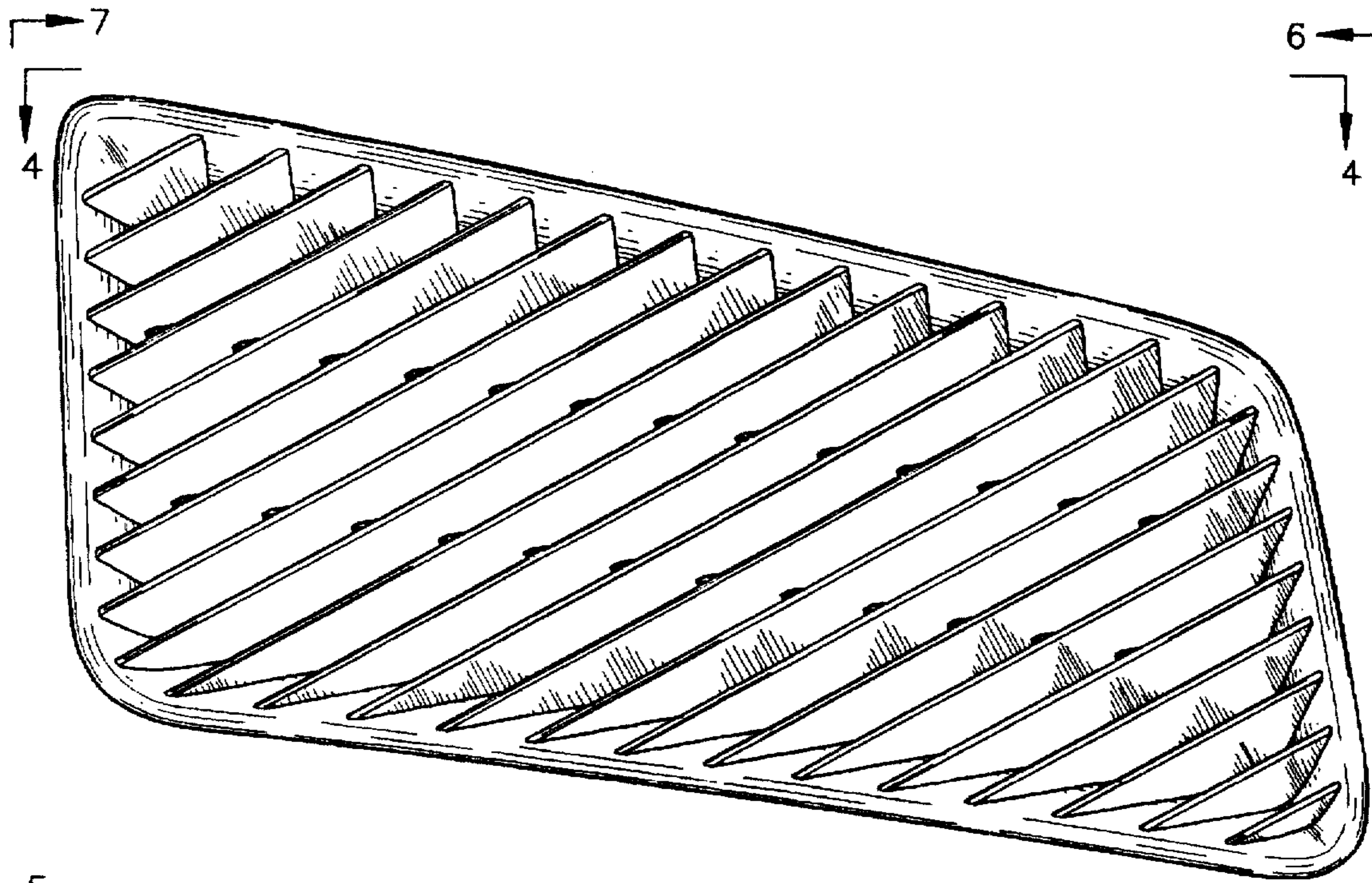

Fig.2

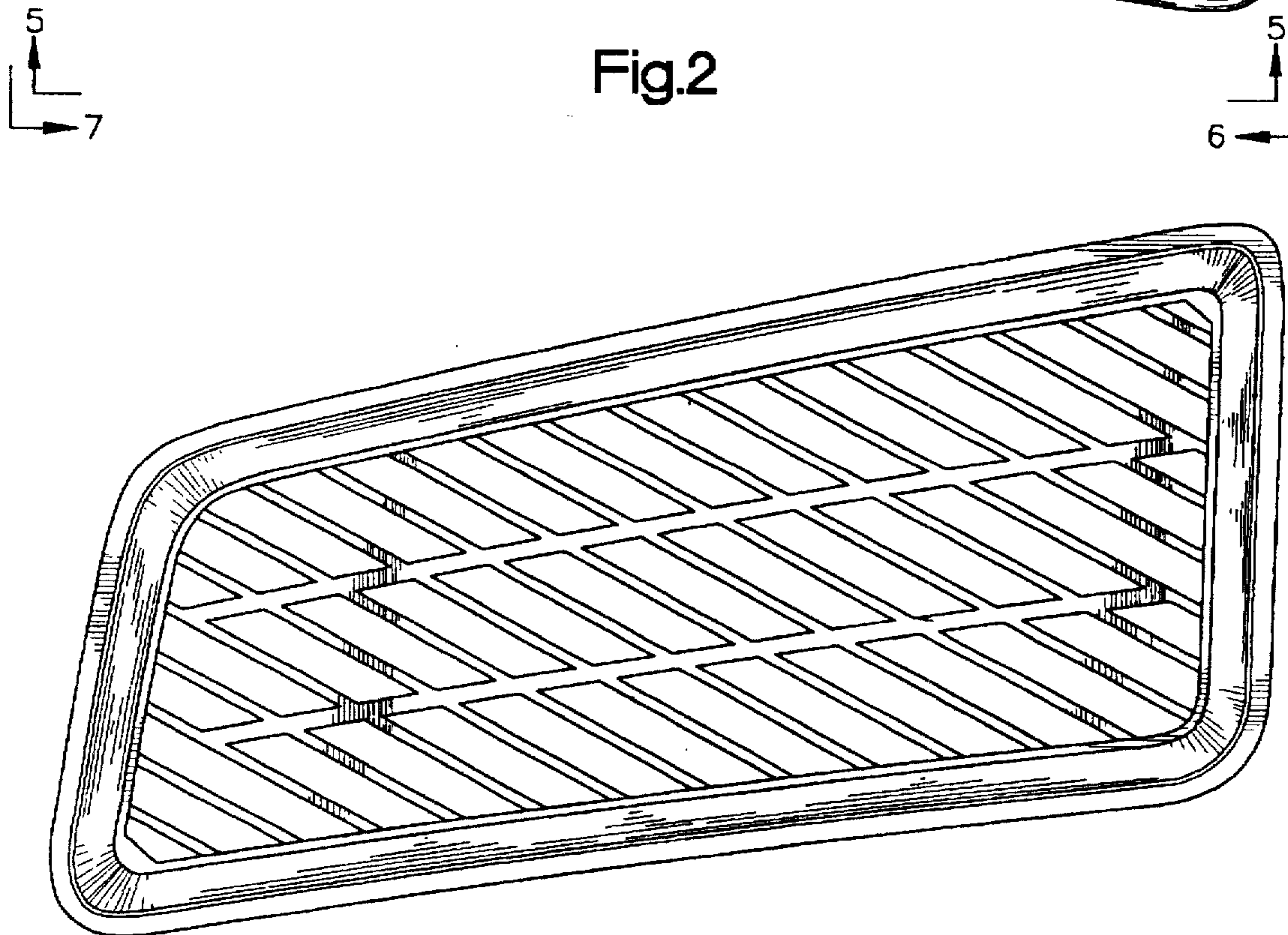

Fig.3

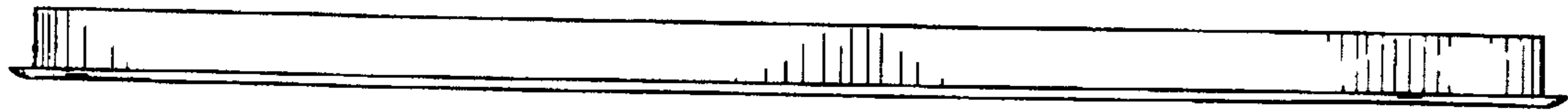

Fig.4

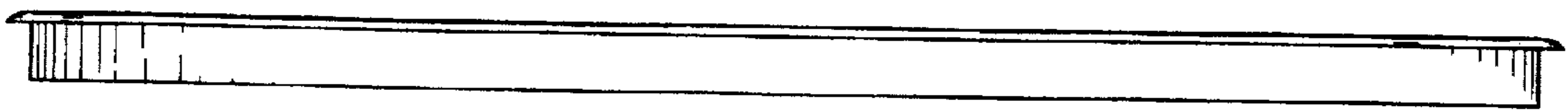

Fig.5



Fig.6



Fig.7