



US00D393681S

United States Patent [19]

Peterson

[11] Patent Number: **Des. 393,681**

[45] Date of Patent: ****Apr. 21, 1998**

[54] AQUATIC VEHICLE

3,135,978 6/1964 Grasmoen 441/131
5,090,930 2/1992 Walden 441/131

[75] Inventor: **Leroy L. Peterson, Omaha, Nebr.**

Primary Examiner—Kay H. Chin
Attorney, Agent, or Firm—Henderson & Sturm

[73] Assignee: **Sportsstuff, Inc., Omaha, Nebr.**

[**] Term: **14 Years**

[57] CLAIM

[21] Appl. No.: **68,109**

The ornamental design for an aquatic vehicle, as shown and described.

[22] Filed: **Feb. 20, 1997**

DESCRIPTION

[51] LOC (6) Cl. **12-06**

[52] U.S. Cl. **D21/237**

[58] Field of Search D21/236, 237;
D12/316; 441/40, 66, 67, 129, 130, 131;
482/111

FIG. 1 is a front perspective view of an aquatic vehicle showing my new design, wherein the broken lines depict the aft end of a motor boat for environmental purposes only and form no part of the claimed design;

FIG. 2 is a left side elevational view thereof;

FIG. 3 is a right side elevational view thereof;

FIG. 4 is a front elevational view thereof;

FIG. 5 is a rear elevational view thereof;

FIG. 6 is a top plan view thereof; and,

FIG. 7 is a bottom plan view thereof.

[56] References Cited

U.S. PATENT DOCUMENTS

D. 287,528 12/1986 Maxwell et al. D21/237
D. 305,449 1/1990 Rundquist, Jr. D21/237
D. 340,495 10/1993 Mitch et al. D21/237

1 Claim, 2 Drawing Sheets

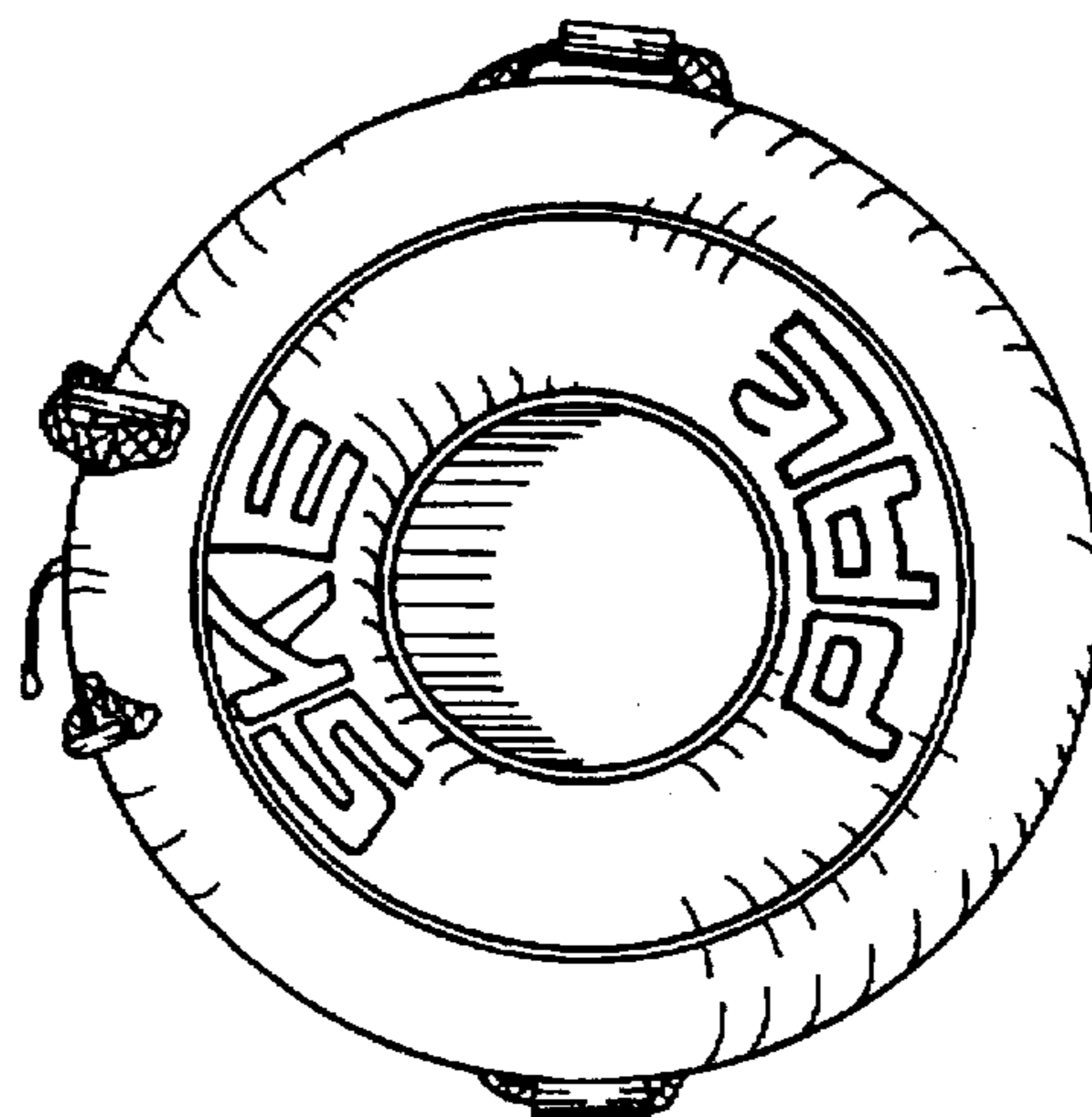
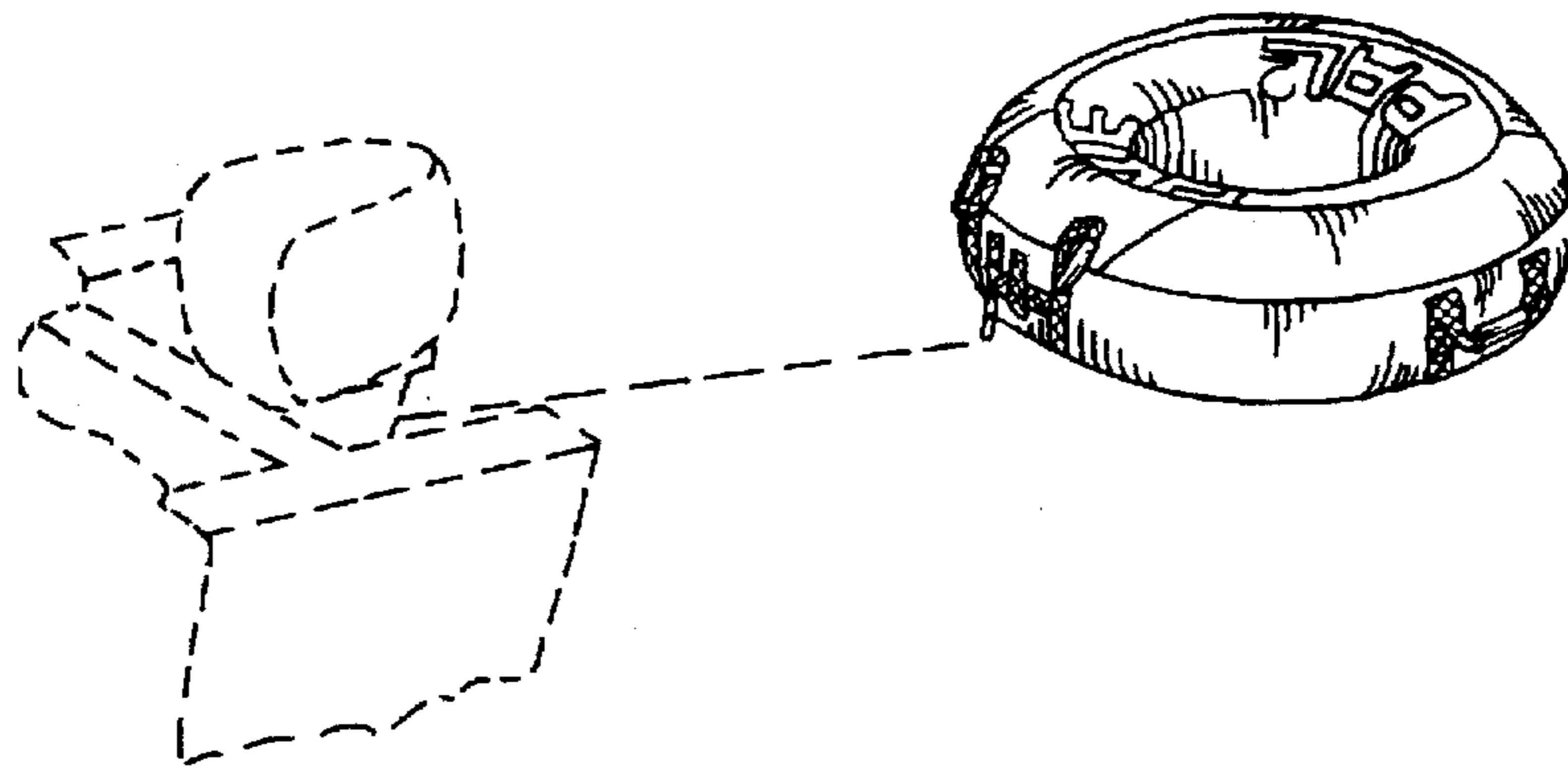

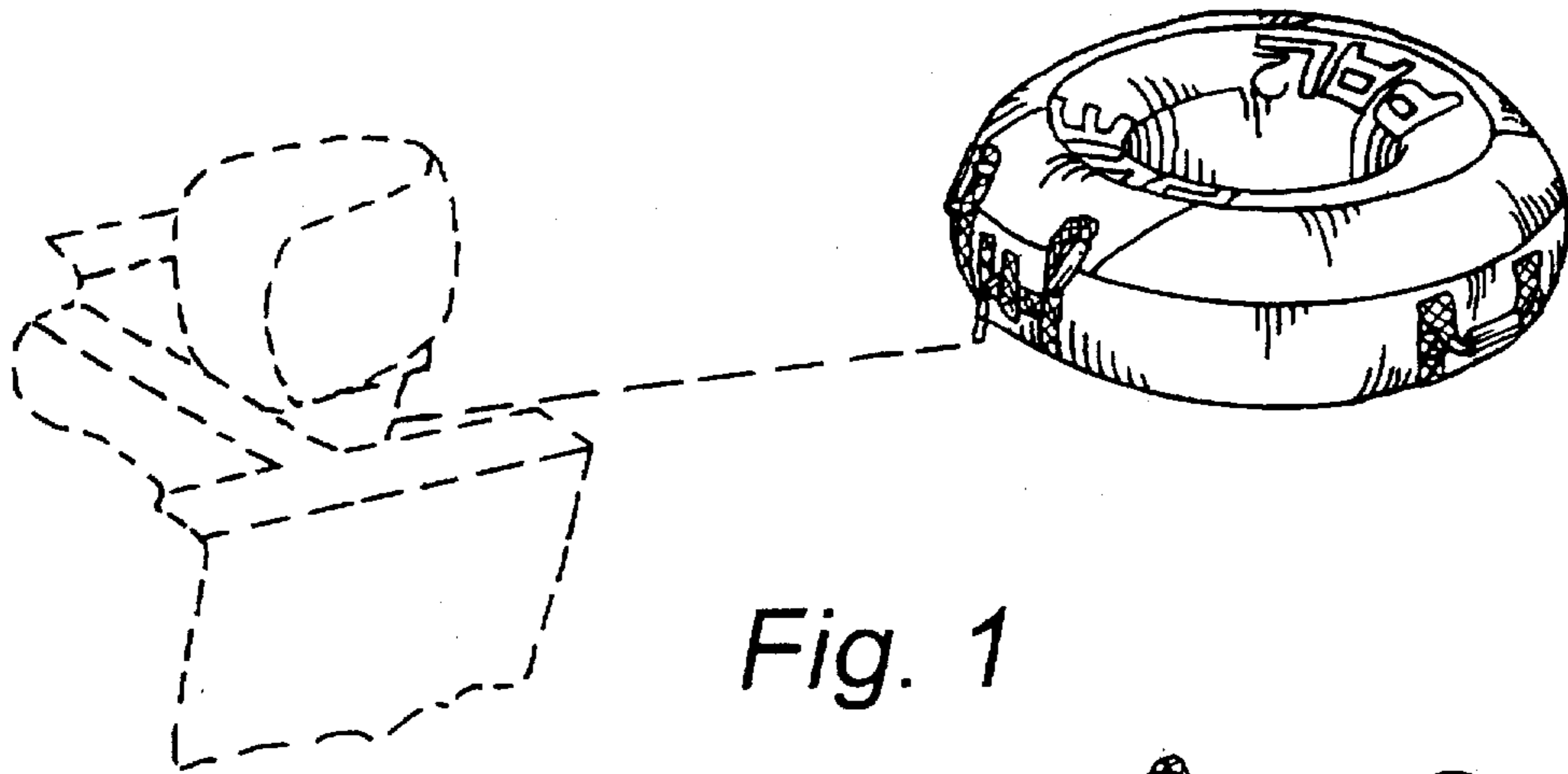

Fig. 1

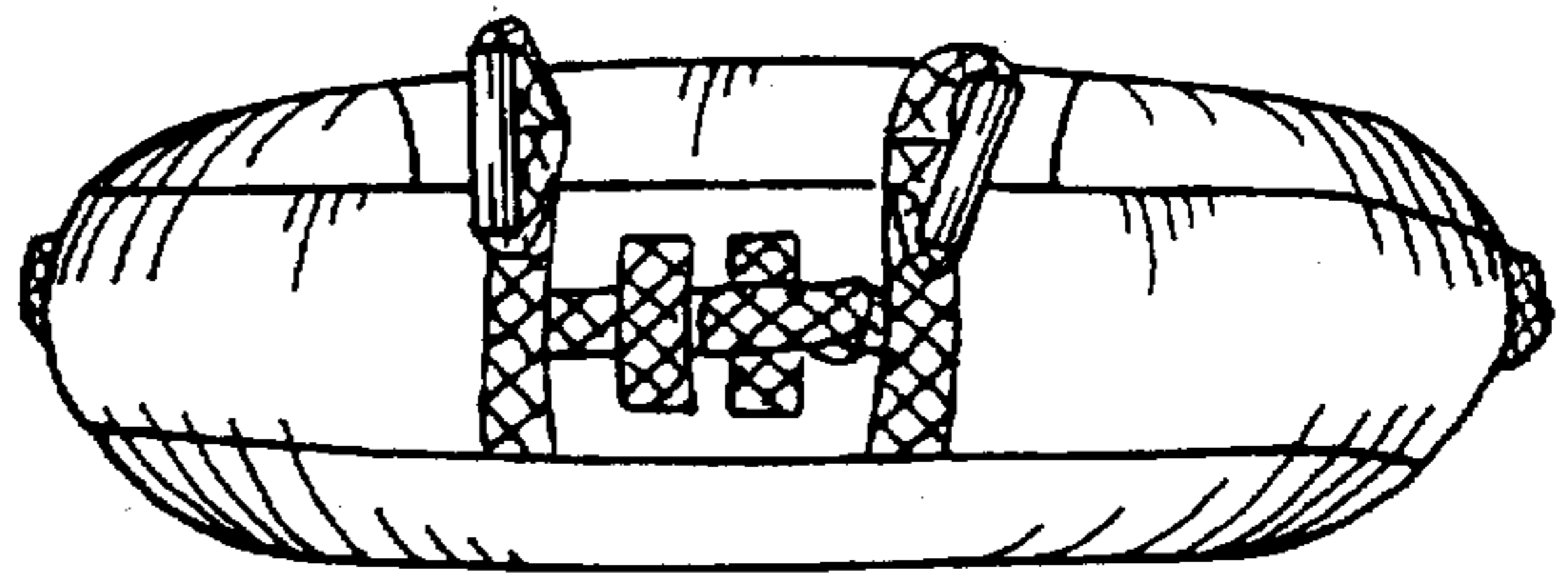

Fig. 4

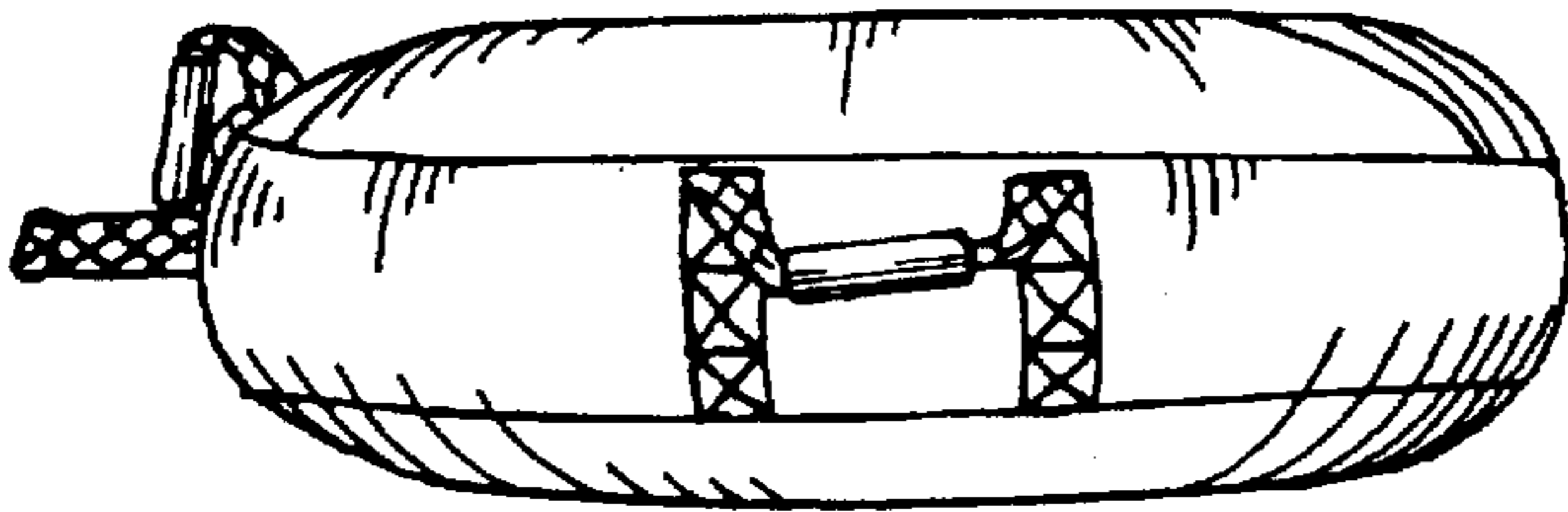

Fig. 2

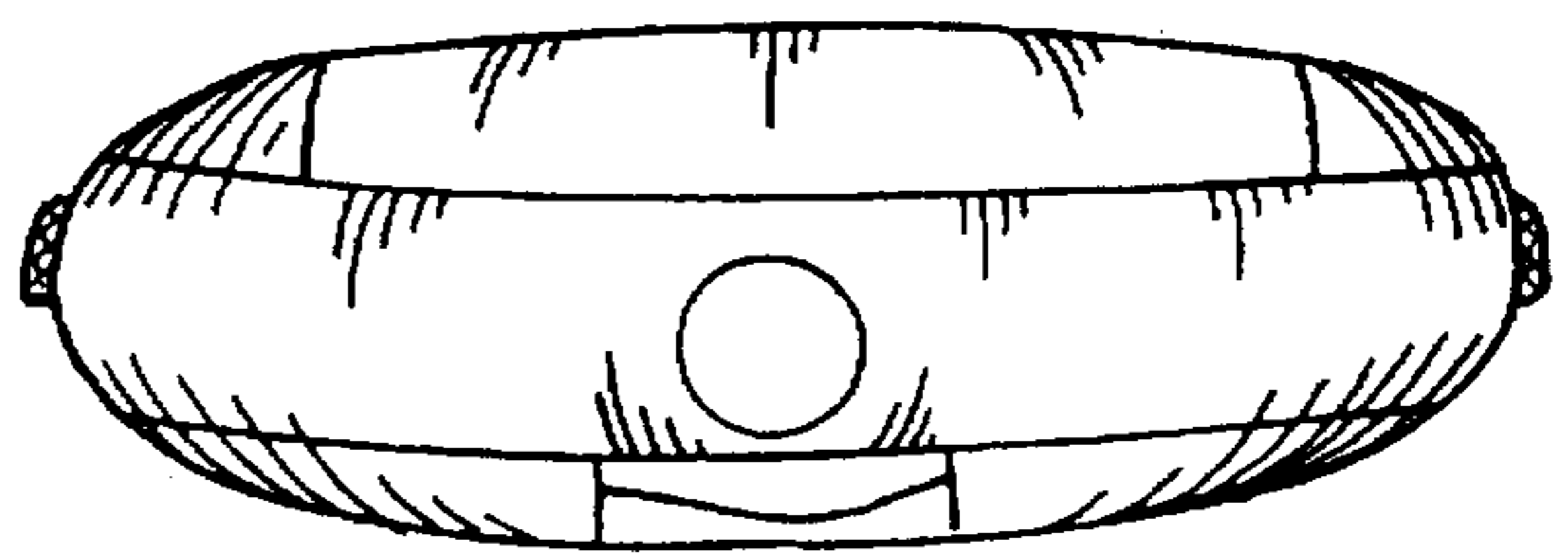

Fig. 5

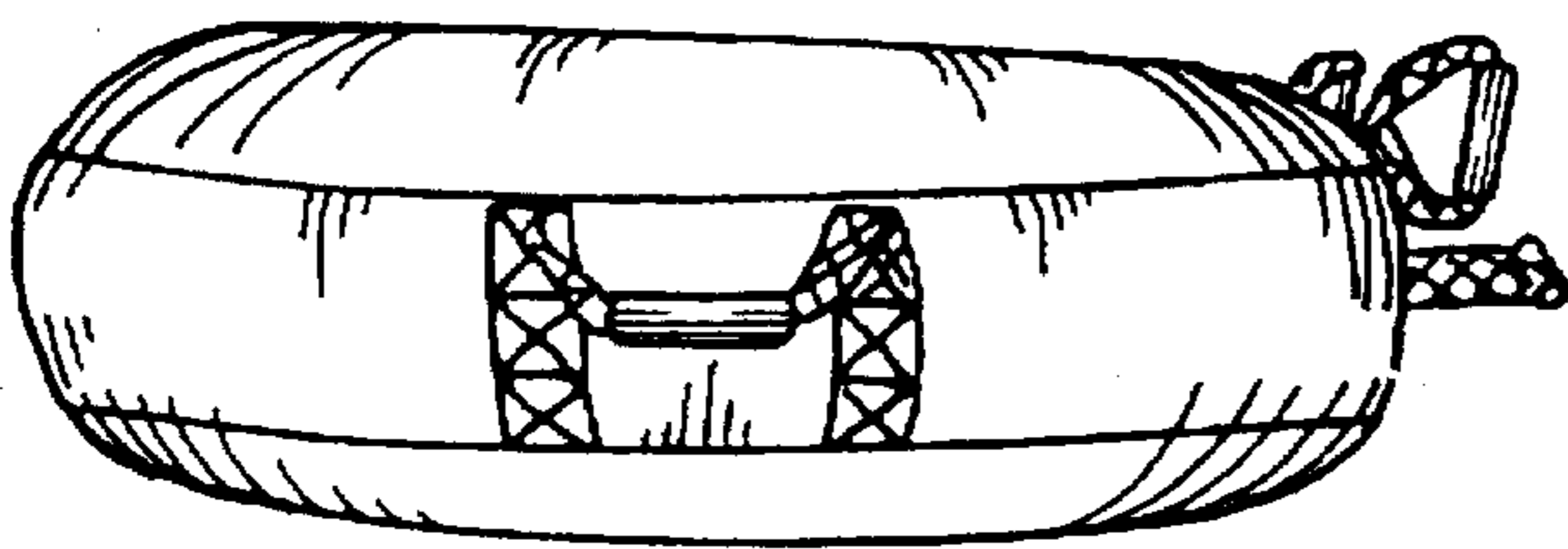

Fig. 3

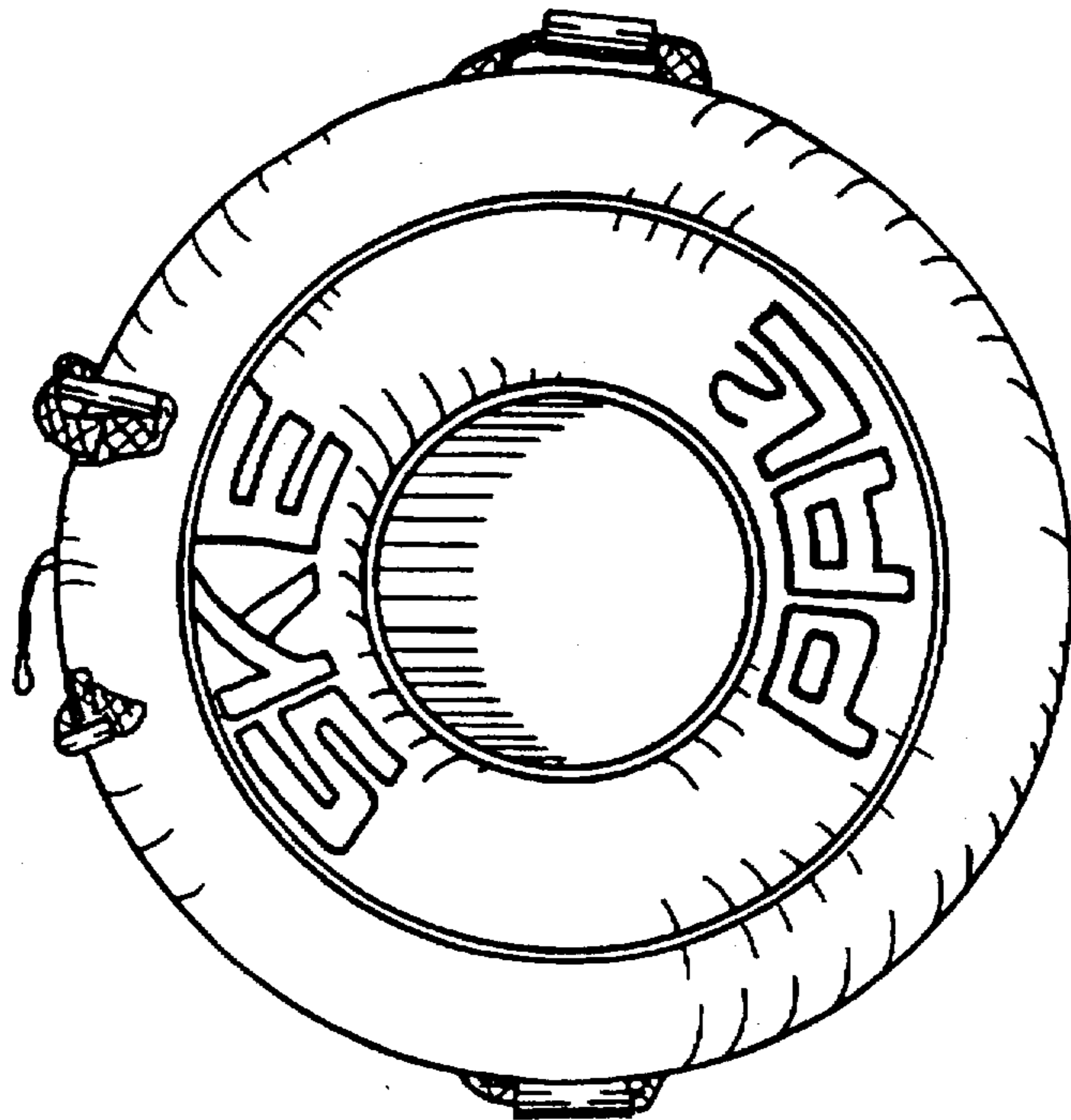

Fig. 6

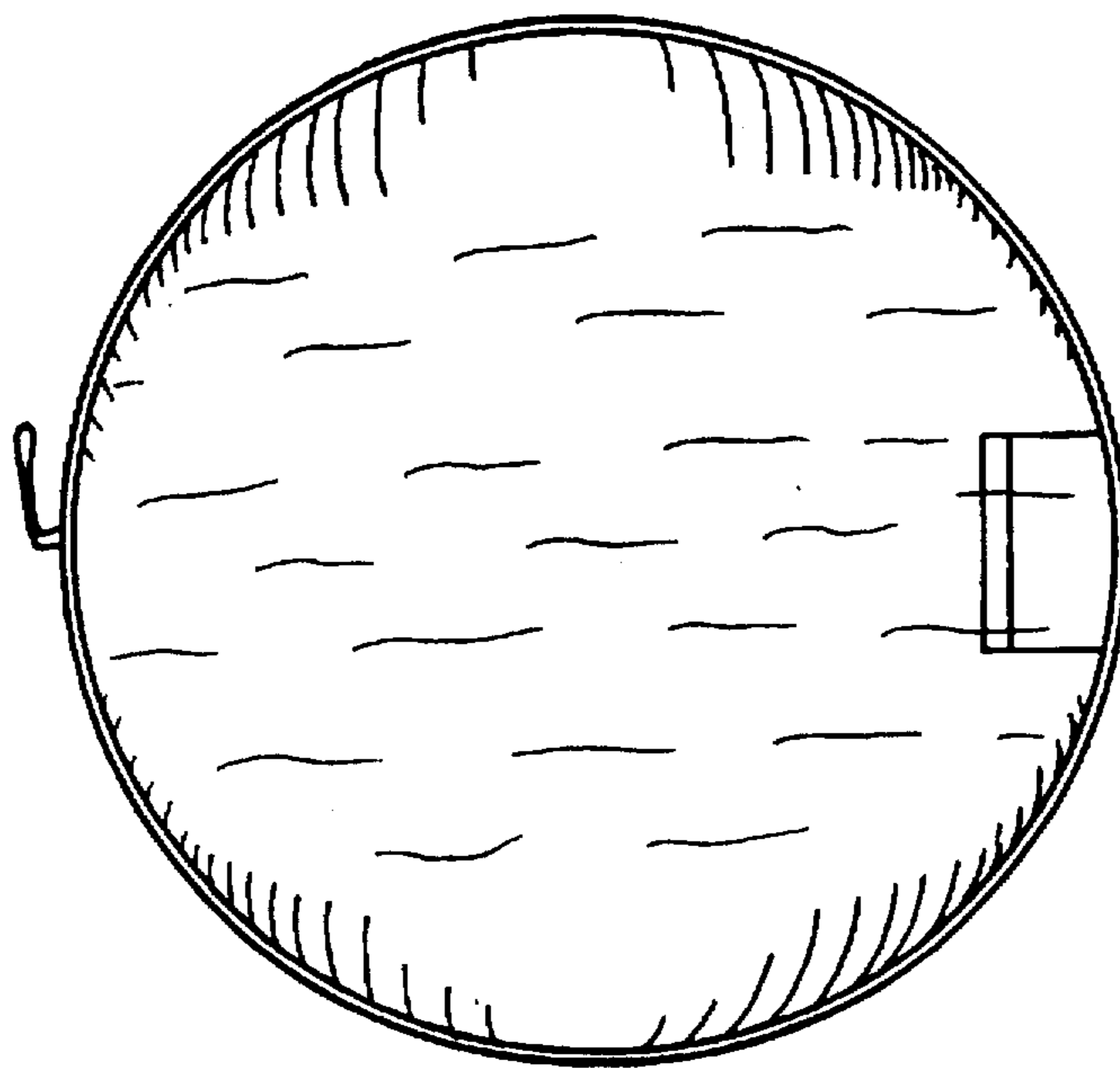

Fig. 7