



US00D393621S

United States Patent [19]

Gregory

[11] Patent Number: **Des. 393,621**

[45] Date of Patent: ****Apr. 21, 1998**

[54] **ADJUSTABLE SPACER/STABILIZER FOR A BIKE RACK**

[76] Inventor: **John K. Gregory**, 8465 Ramsey Rd., Gold Hill, Oreg. 97525

[**] Term: **14 Years**

[21] Appl. No.: **70,750**

[22] Filed: **Apr. 8, 1997**

[51] LOC (6) Cl. **12-16**

[52] U.S. Cl. **D12/408**

[58] Field of Search D12/408; 211/17-22; 290/415.1; 244/500-513, 521, 537, 917.5, 924

[56] **References Cited**

U.S. PATENT DOCUMENTS

D. 369,585	5/1996	Gregory	D12/408
D. 378,669	4/1997	Gregory	D12/162
3,891,132	6/1975	Chandler	224/509
5,067,641	11/1991	Johnson et al.	224/501
5,096,102	3/1992	Tolson	224/513
5,244,133	9/1993	Abbott et al.	224/521
5,282,555	2/1994	Muir et al.	224/532
5,303,857	4/1994	Newson	224/506
5,489,110	2/1996	Van Deusen	224/507 X
5,544,763	8/1996	McClain	211/22
5,558,261	9/1996	Hedeen	224/511

Primary Examiner—Melody N. Brown
Attorney, Agent, or Firm—Richard C. Litman

[57] **CLAIM**

The ornamental design for an adjustable spacer/stabilizer for a bike rack, as shown and described.

DESCRIPTION

FIG. 1 is a perspective view of an adjustable spacer/stabilizer for a bike rack showing my new design mounted on a bike rack which, in turn, is mounted on the trailer hitch of a pickup truck;

FIG. 2 is a perspective view similar to FIG. 1 but showing the invention mounted on a bike rack which, in turn, is mounted on a motorcycle;

FIG. 3 is a left side elevational view thereof;

FIG. 4 is a right side elevational view thereof;

FIG. 5 is a front elevational view thereof;

FIG. 6 is a rear elevational view thereof;

FIG. 7 is a top view thereof; and,

FIG. 8 is a bottom view thereof.

The broken line showing of portions of a truck and motorcycle in FIGS. 1 and 2, respectively, and a bike rack in FIGS. 1 and 2 is for illustrative purposes only and forms no part of the claimed design.

1 Claim, 6 Drawing Sheets

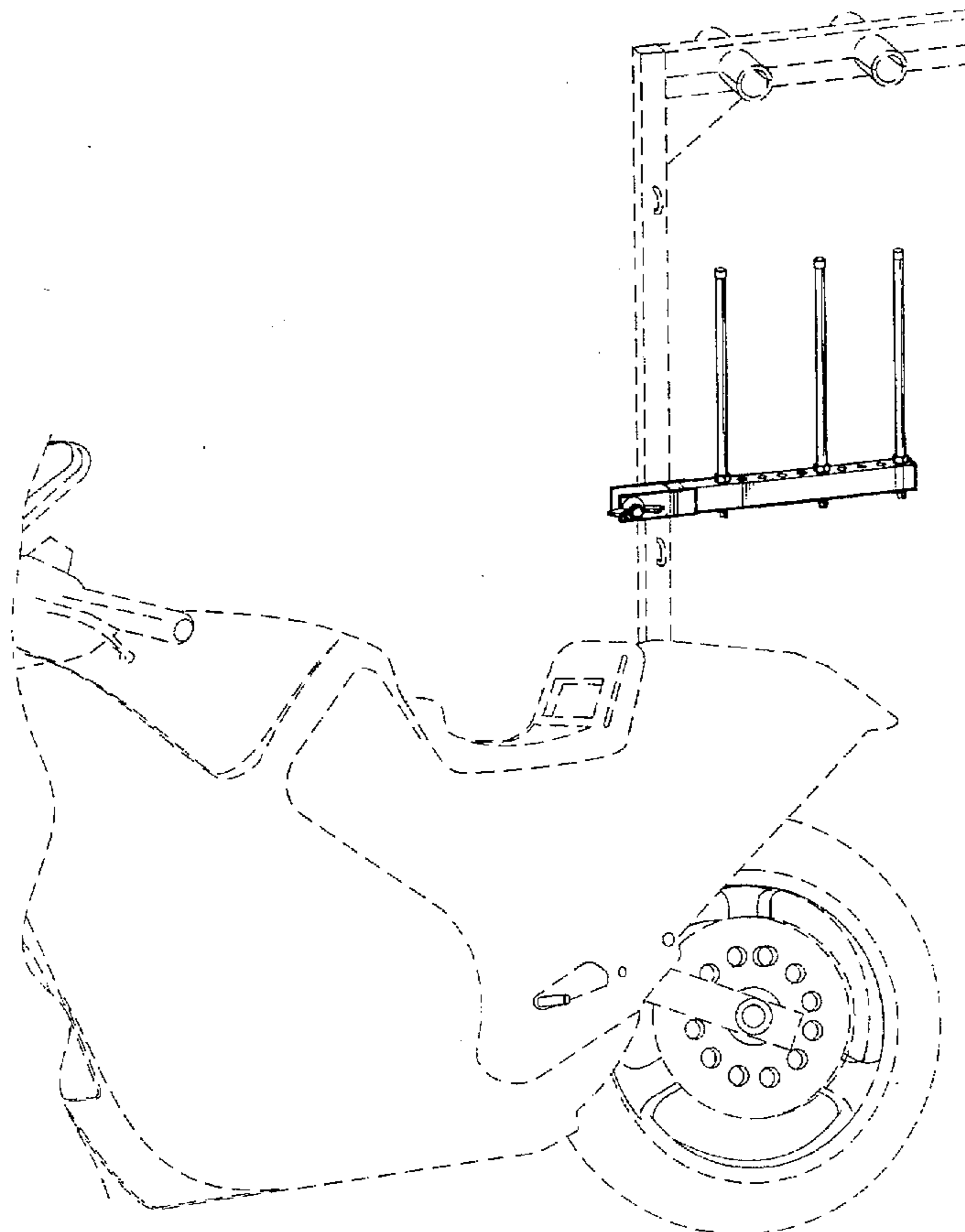

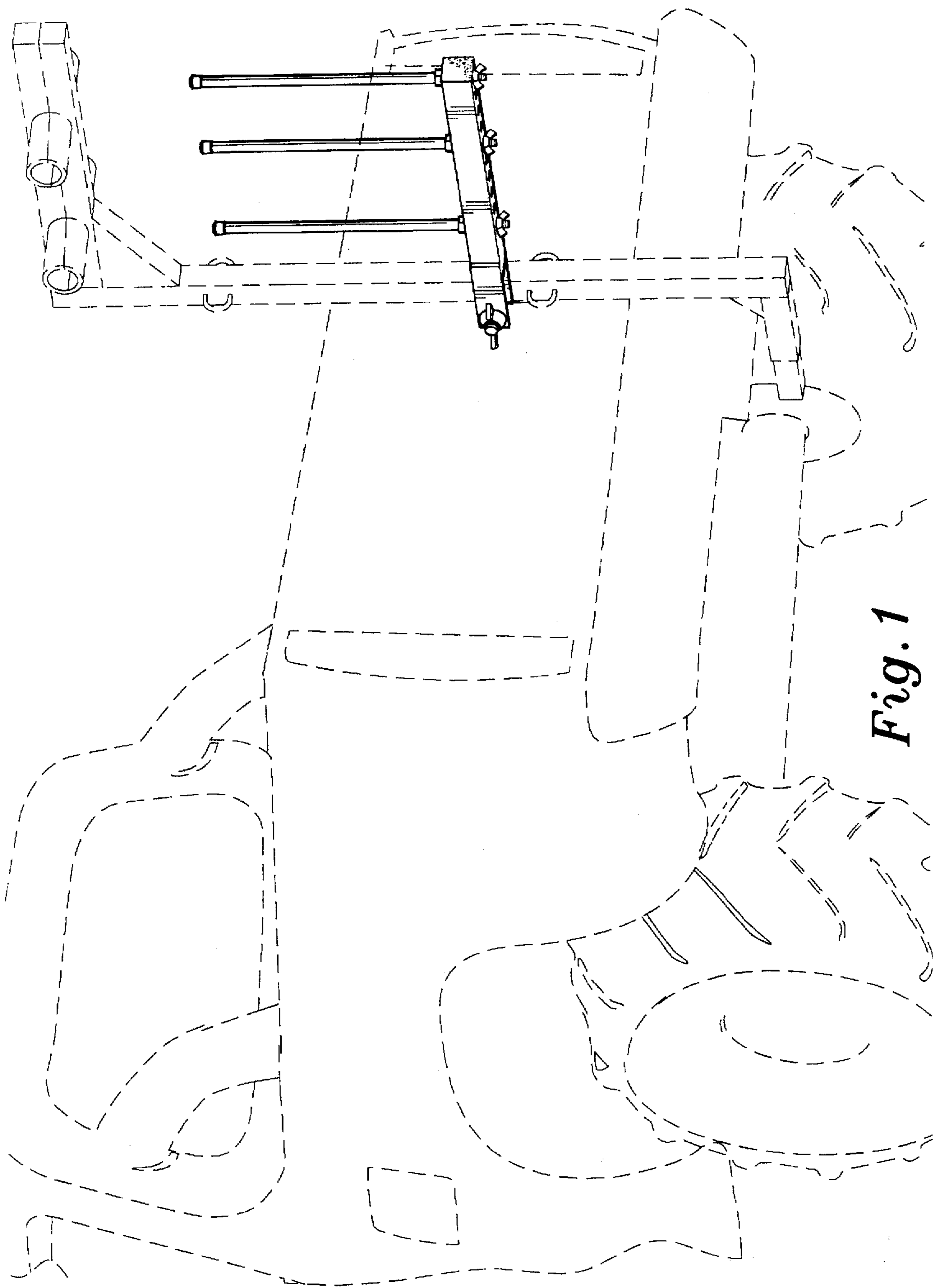

Fig. 1

Fig. 2

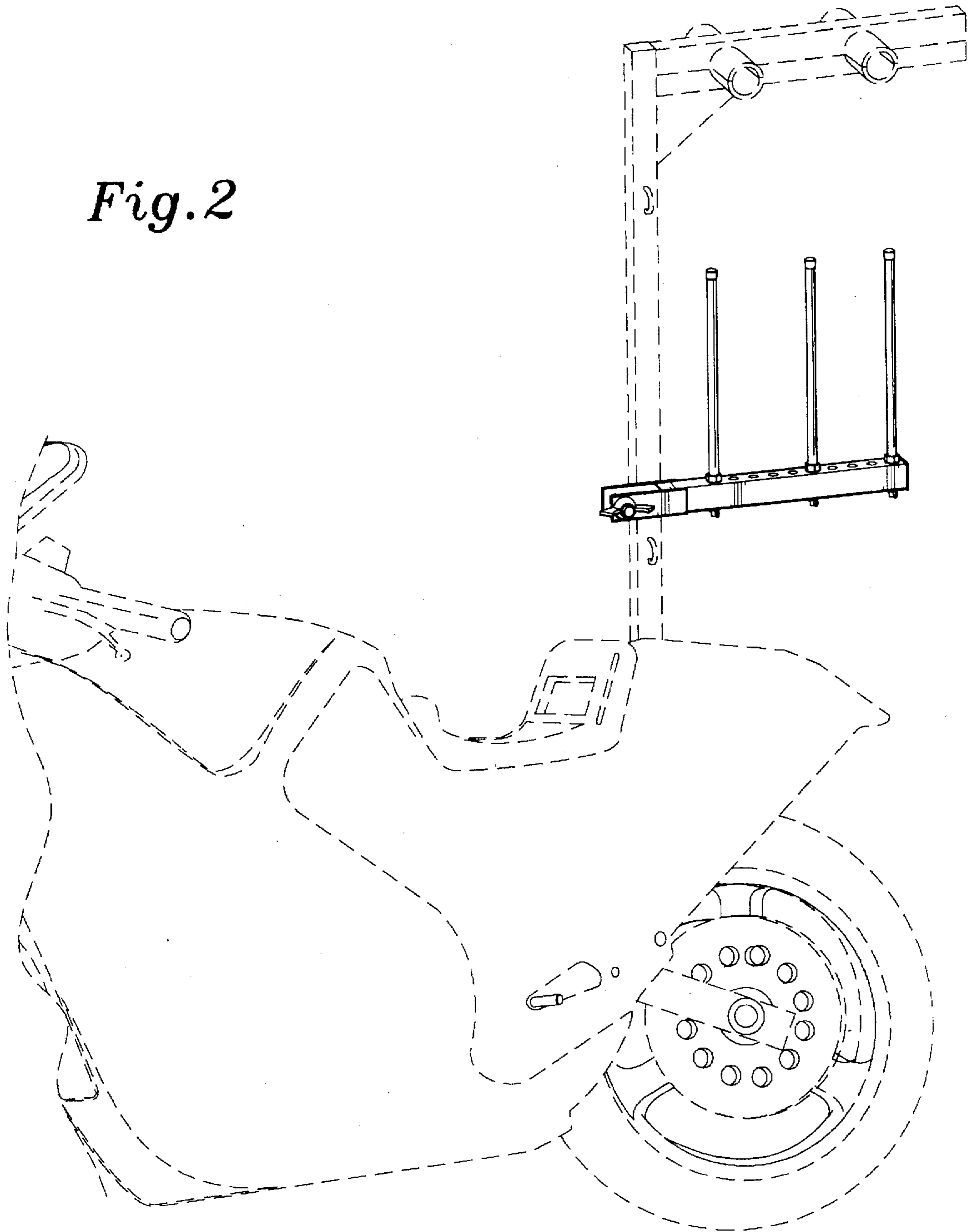

Fig. 3

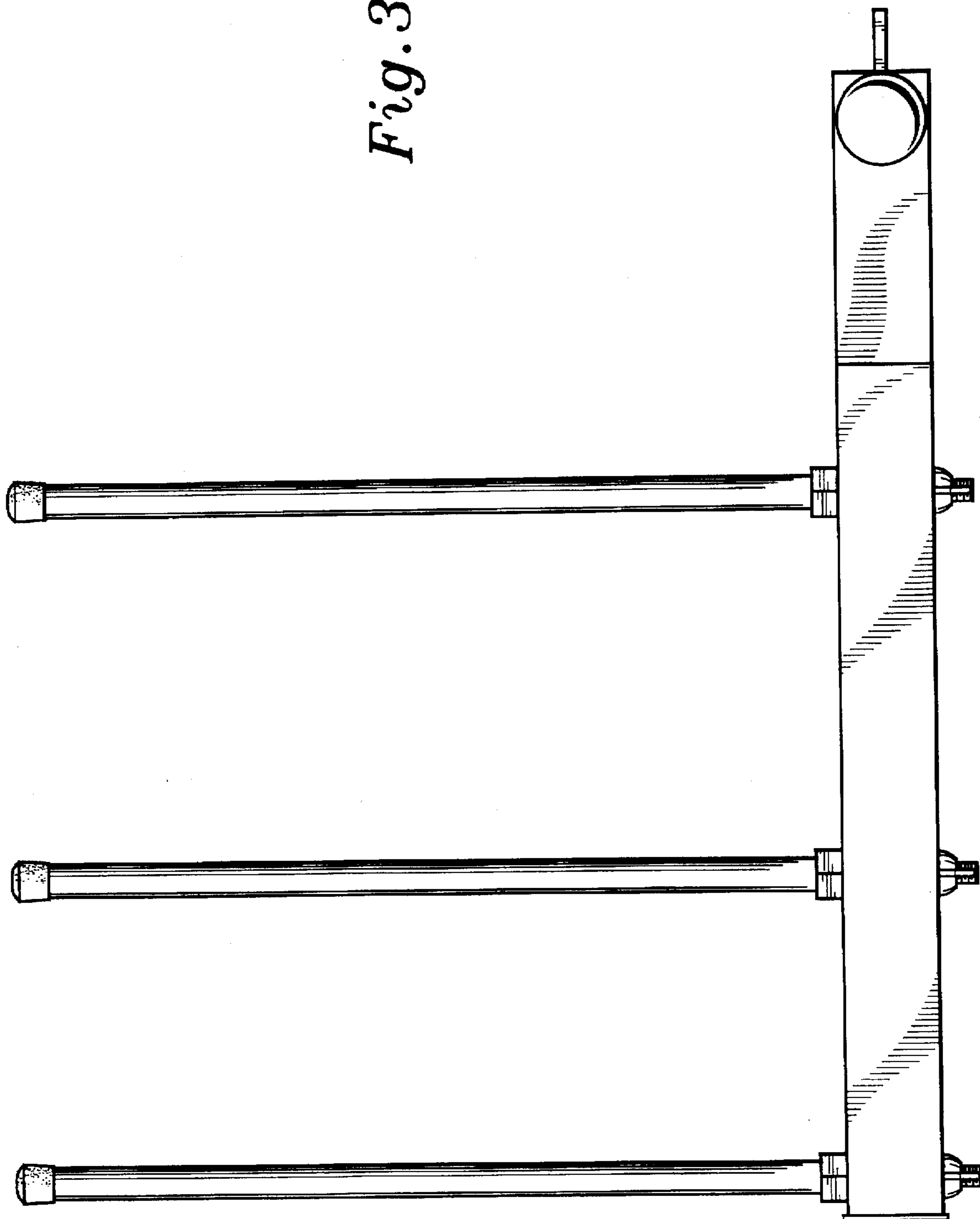
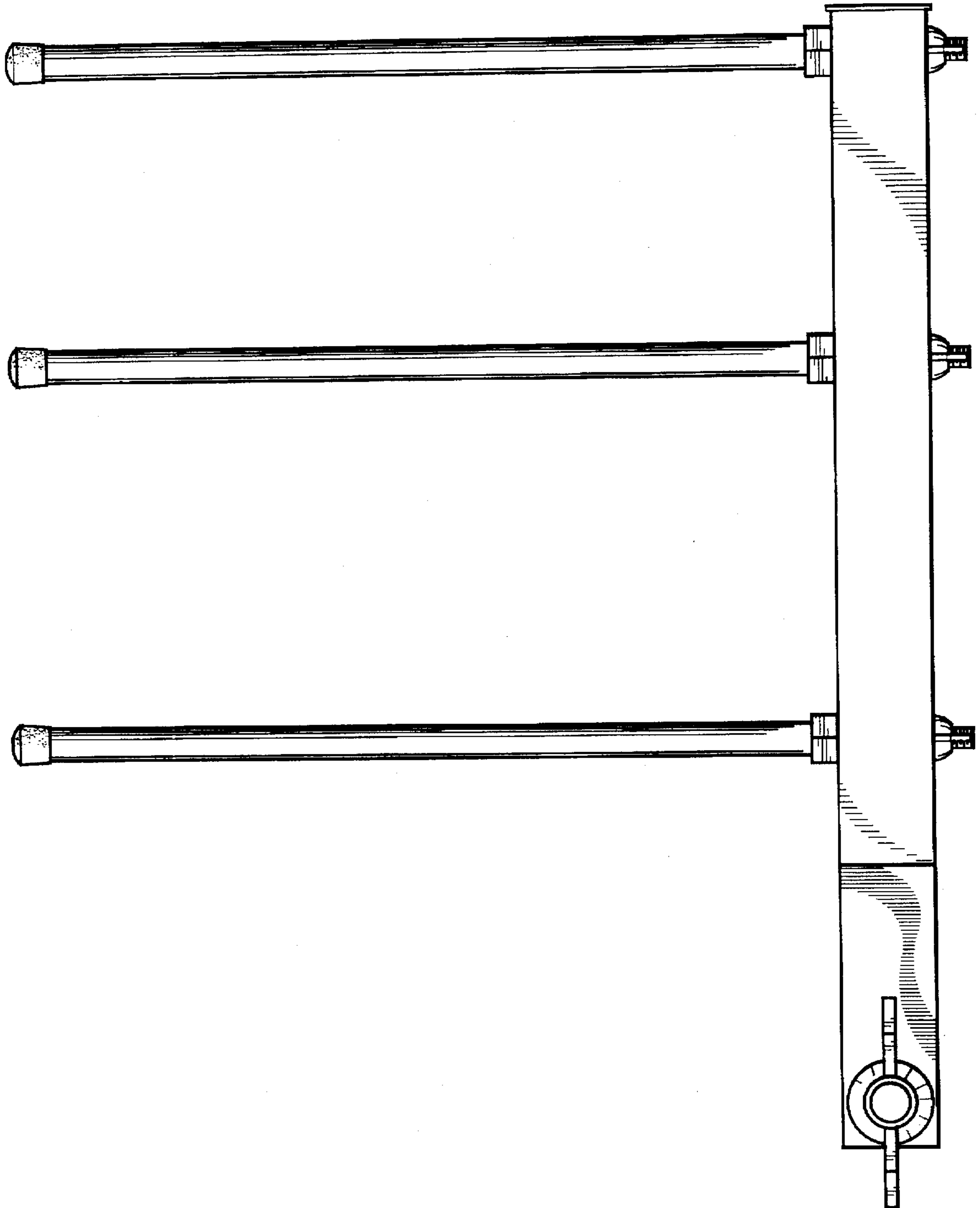

Fig. 4



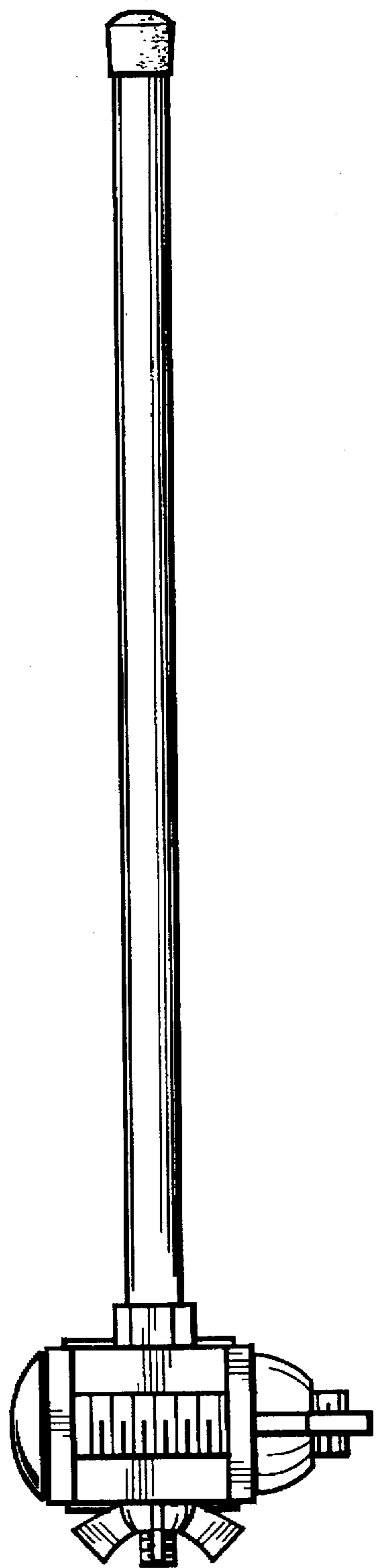

Fig. 5

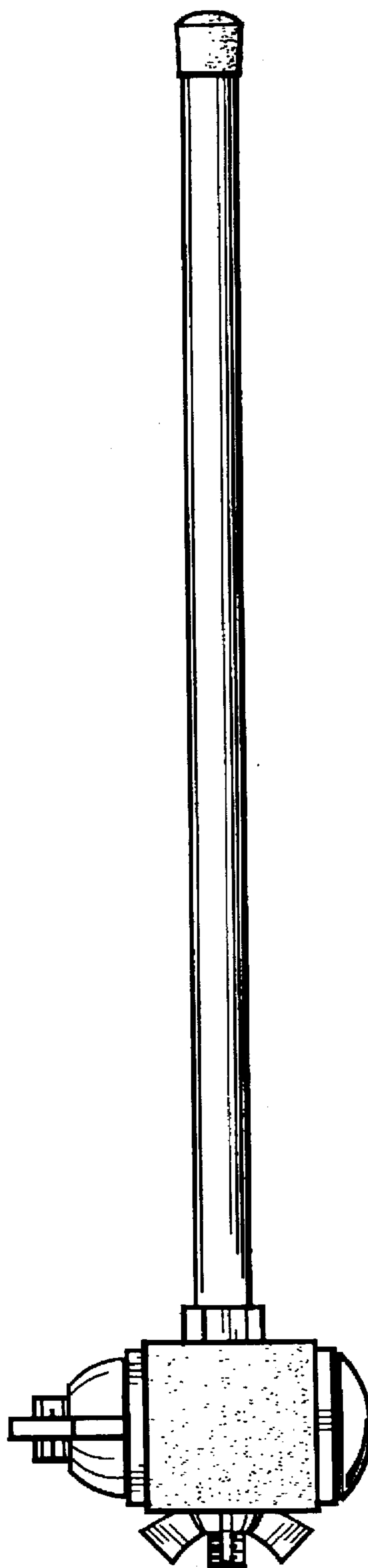

Fig. 6

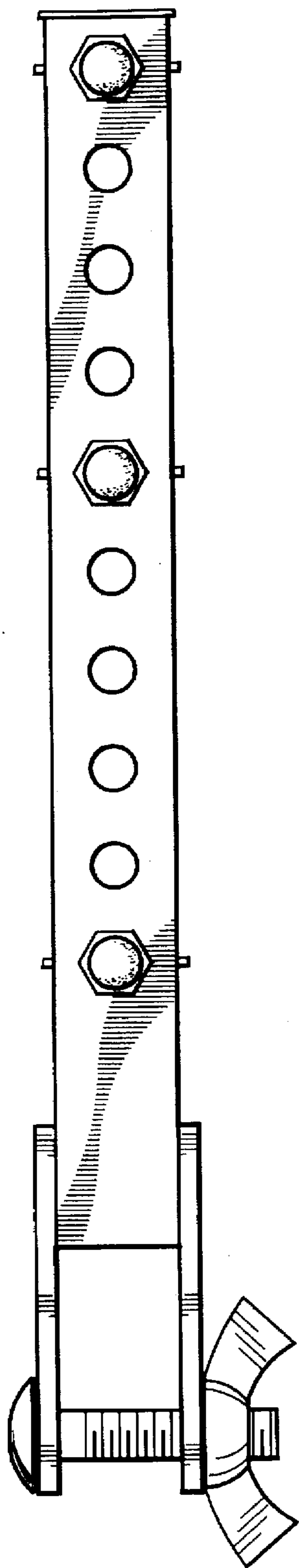

Fig. 7

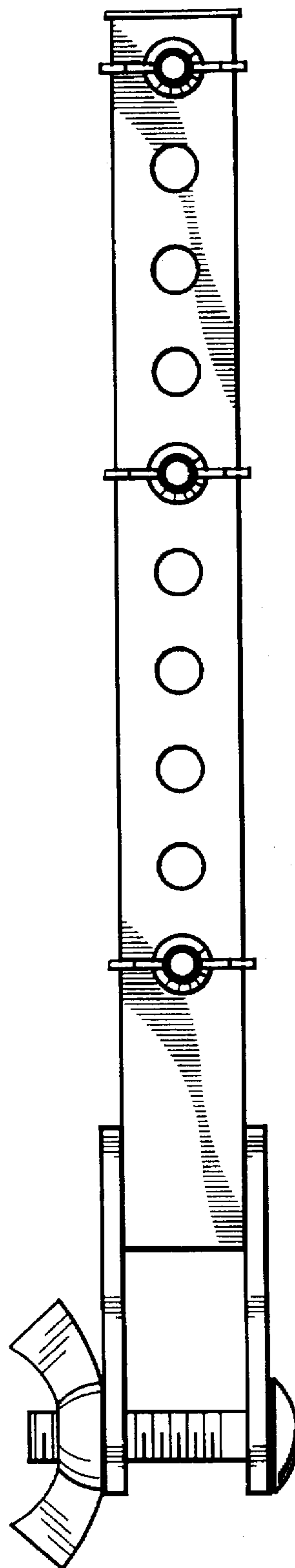

Fig. 8