



US00D393609S

# United States Patent [19]

Kanthak et al.

[11] Patent Number: **Des. 393,609**

[45] Date of Patent: **\*\*Apr. 21, 1998**

[54] **VEHICLE**

[76] Inventors: **Karl E. Kanthak**, 107 NW. 82nd St.,  
Vancouver, Wash. 98665; **James C. Duncan**, 12301 SE. 11th St.,  
Vancouver, Wash. 98684

[\*\*] Term: **14 Years**

[21] Appl. No.: **67,040**

[22] Filed: **Feb. 26, 1997**

[51] **LOC (6) Cl.** ..... **12-08**

[52] **U.S. Cl.** ..... **D12/91**

[58] **Field of Search** ..... D12/12, 14, 86,  
D12/90-92; D21/76, 87; 296/185

[56] **References Cited**

**U.S. PATENT DOCUMENTS**

- D. 172,124 5/1954 Blenkle ..... D12/86
- D. 220,837 6/1971 Mattson ..... D12/98
- D. 246,775 12/1977 Brubaker ..... D12/90

- D. 296,537 7/1988 Kim ..... D12/91
- D. 315,325 3/1991 Legueu ..... D12/96
- D. 328,317 7/1992 Harrod ..... D21/76
- D. 340,208 10/1993 Wolfe ..... D12/92

*Primary Examiner*—Melody N. Brown  
*Attorney, Agent, or Firm*—Curtis L. Harrington

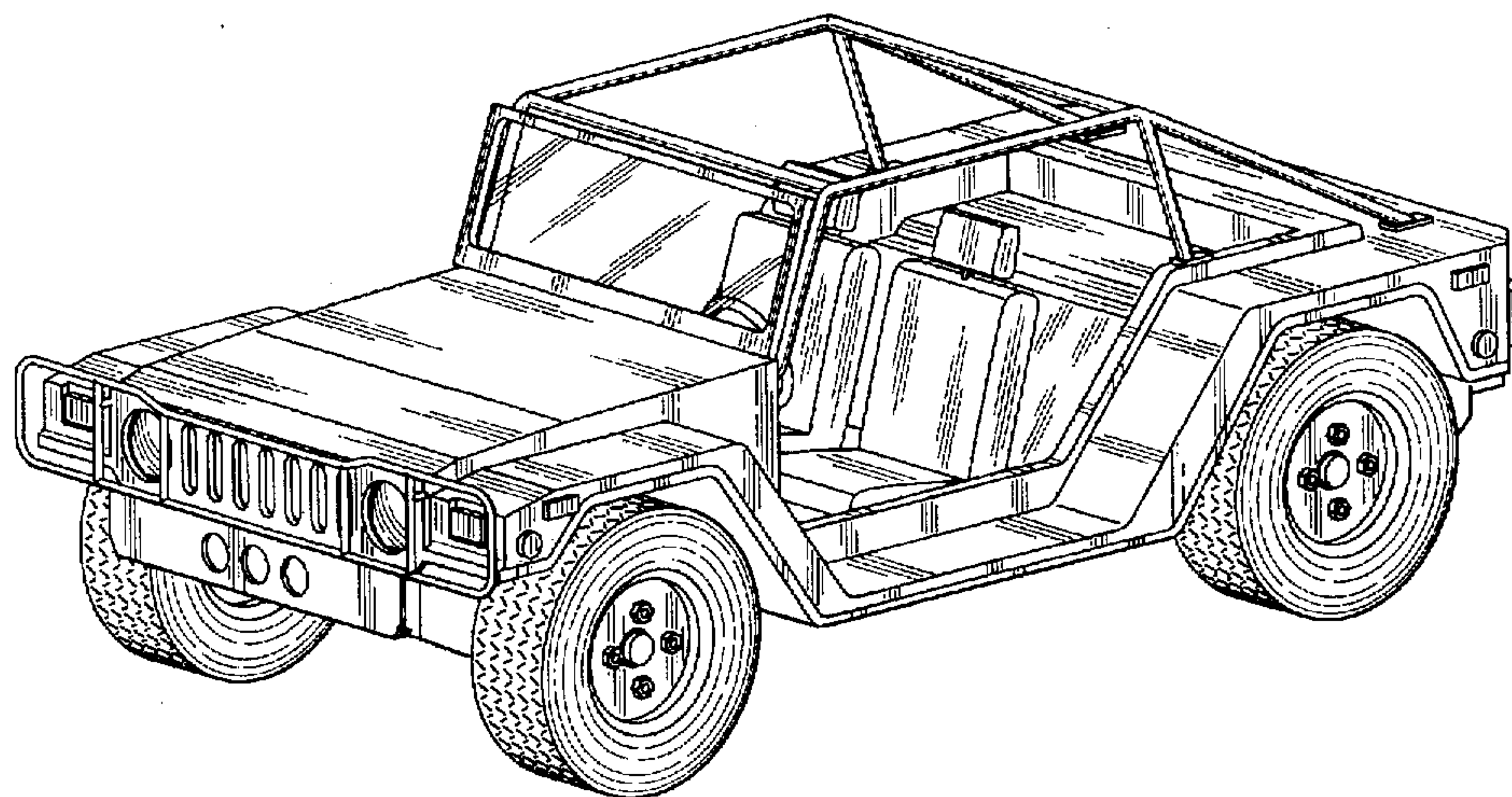
[57] **CLAIM**

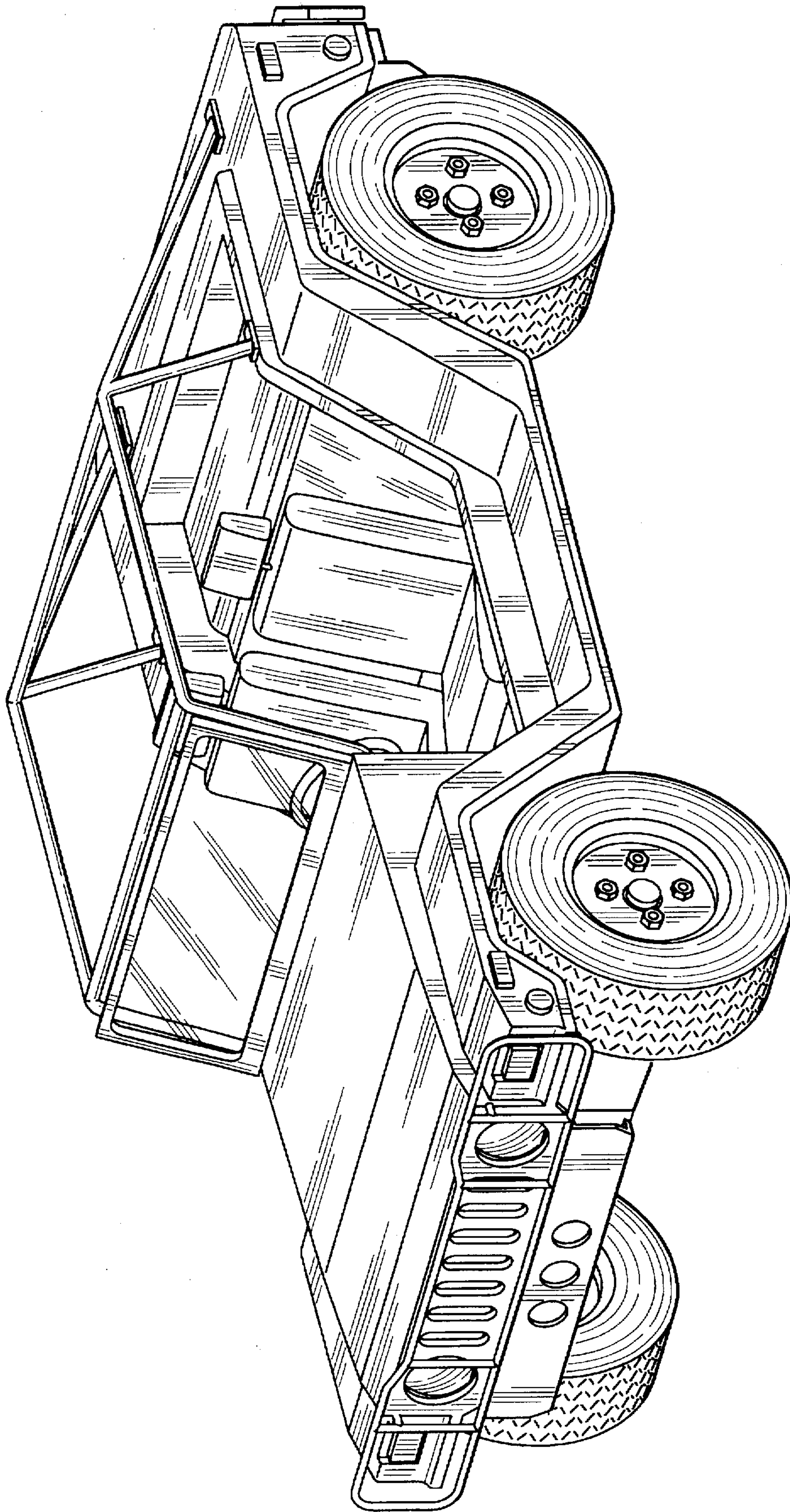
The ornamental design for a vehicle, as shown and described.

**DESCRIPTION**

FIG. 1 is a perspective view of a vehicle according to the present invention;  
FIG. 2 is a right side view of the vehicle of FIG. 1, which is symmetrical to a left side view thereof;  
FIG. 3 is a front view of the vehicle of FIG. 1;  
FIG. 4 is a rear view of the vehicle of FIG. 1;  
FIG. 5 is a top view of the vehicle of FIG. 1; and,  
FIG. 6 is a bottom view of the vehicle of FIG. 1.

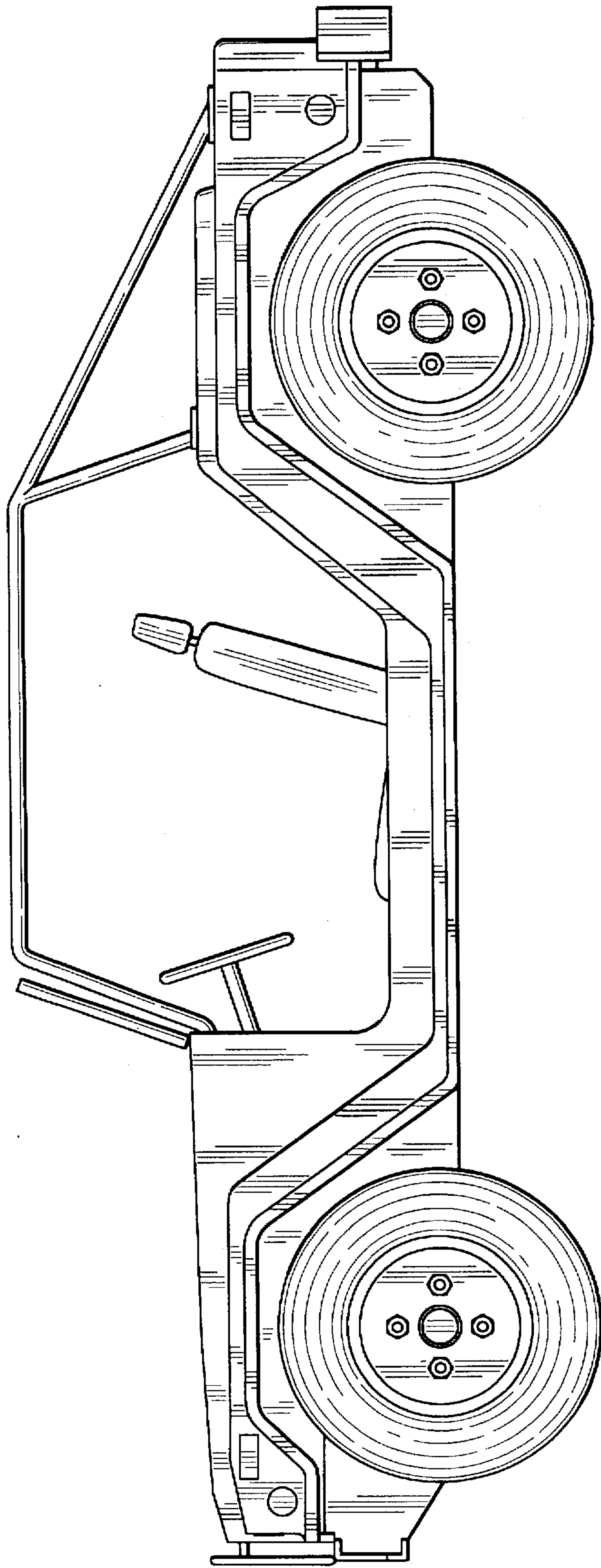
**1 Claim, 5 Drawing Sheets**



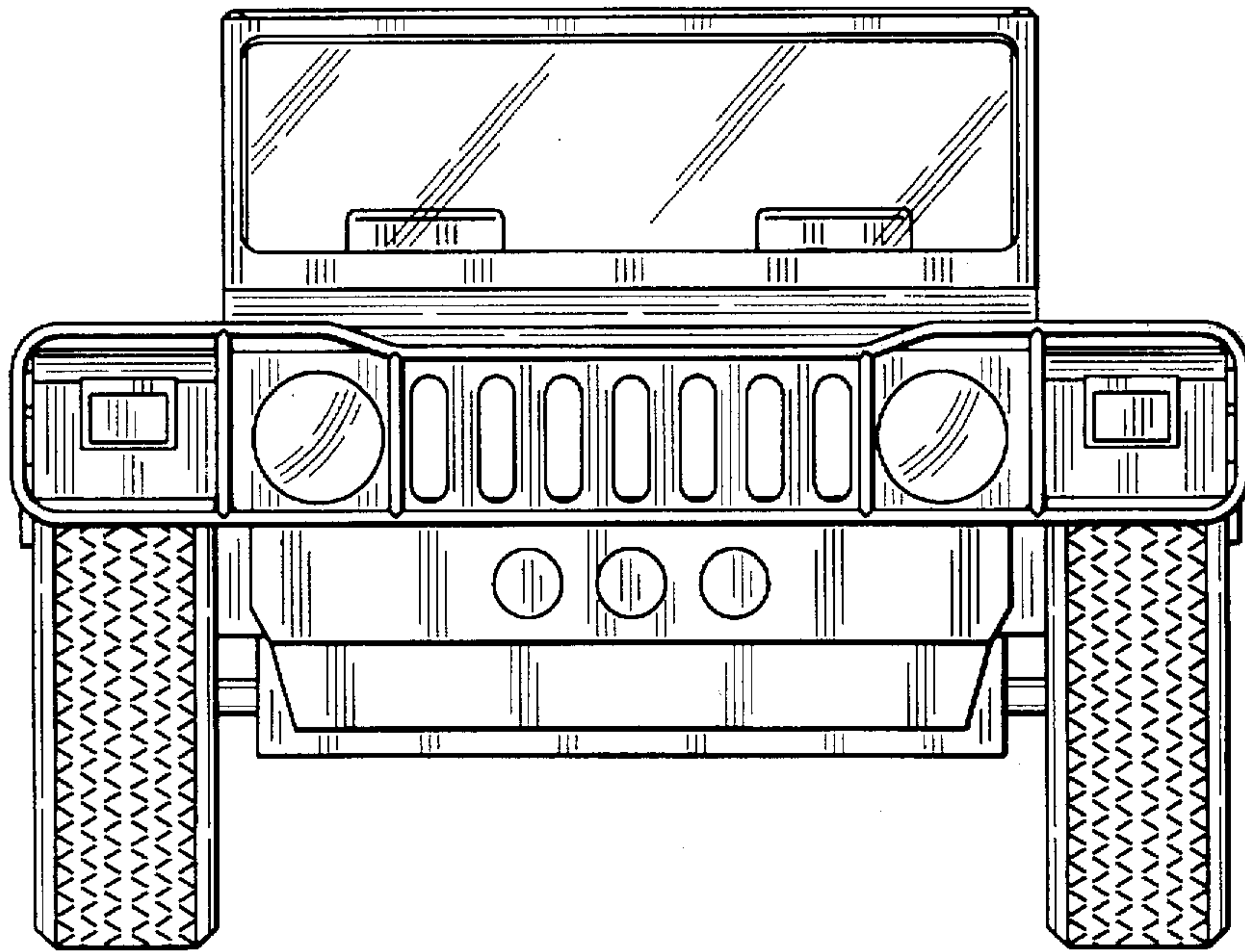


*Fig. 1*

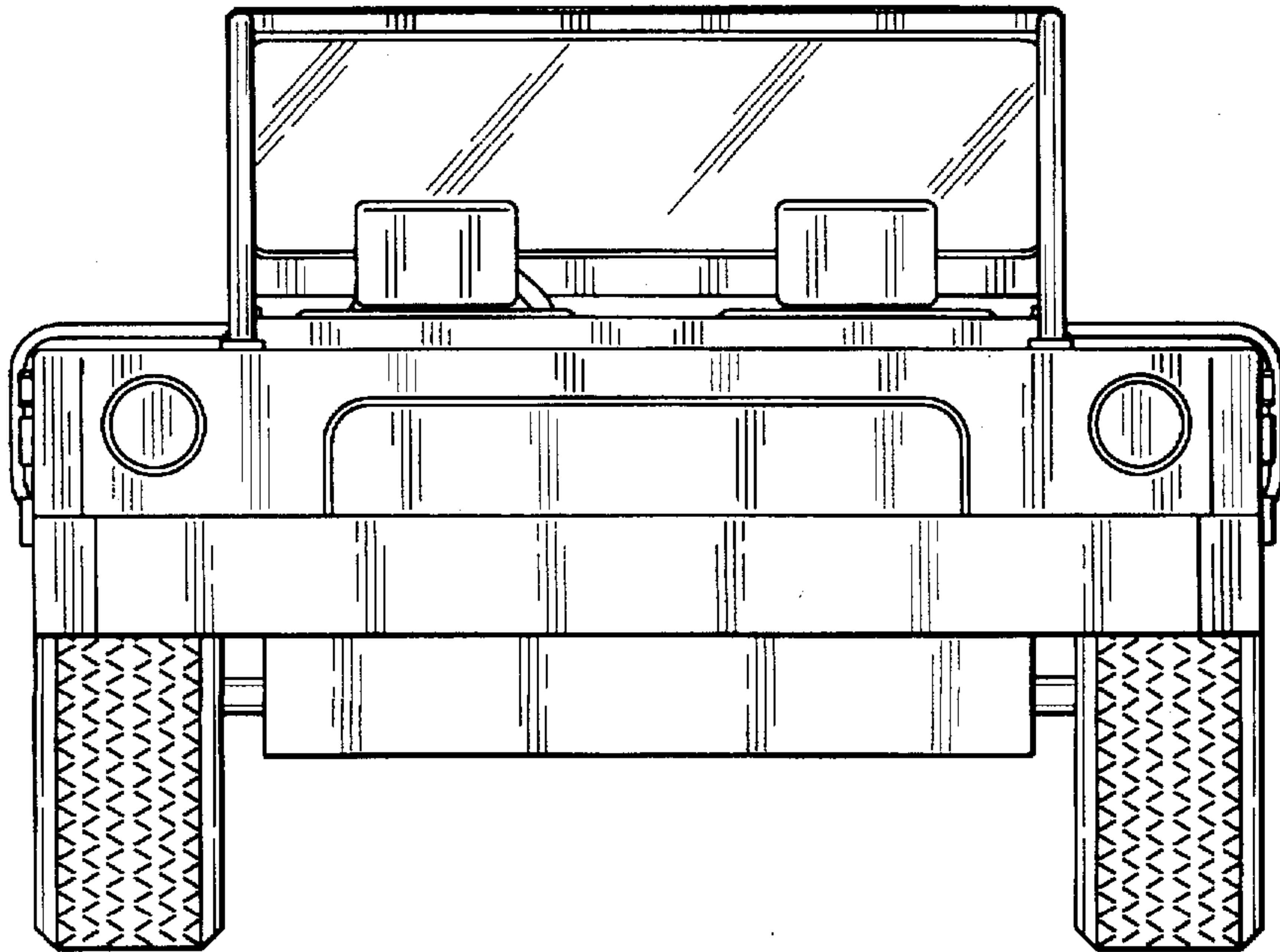




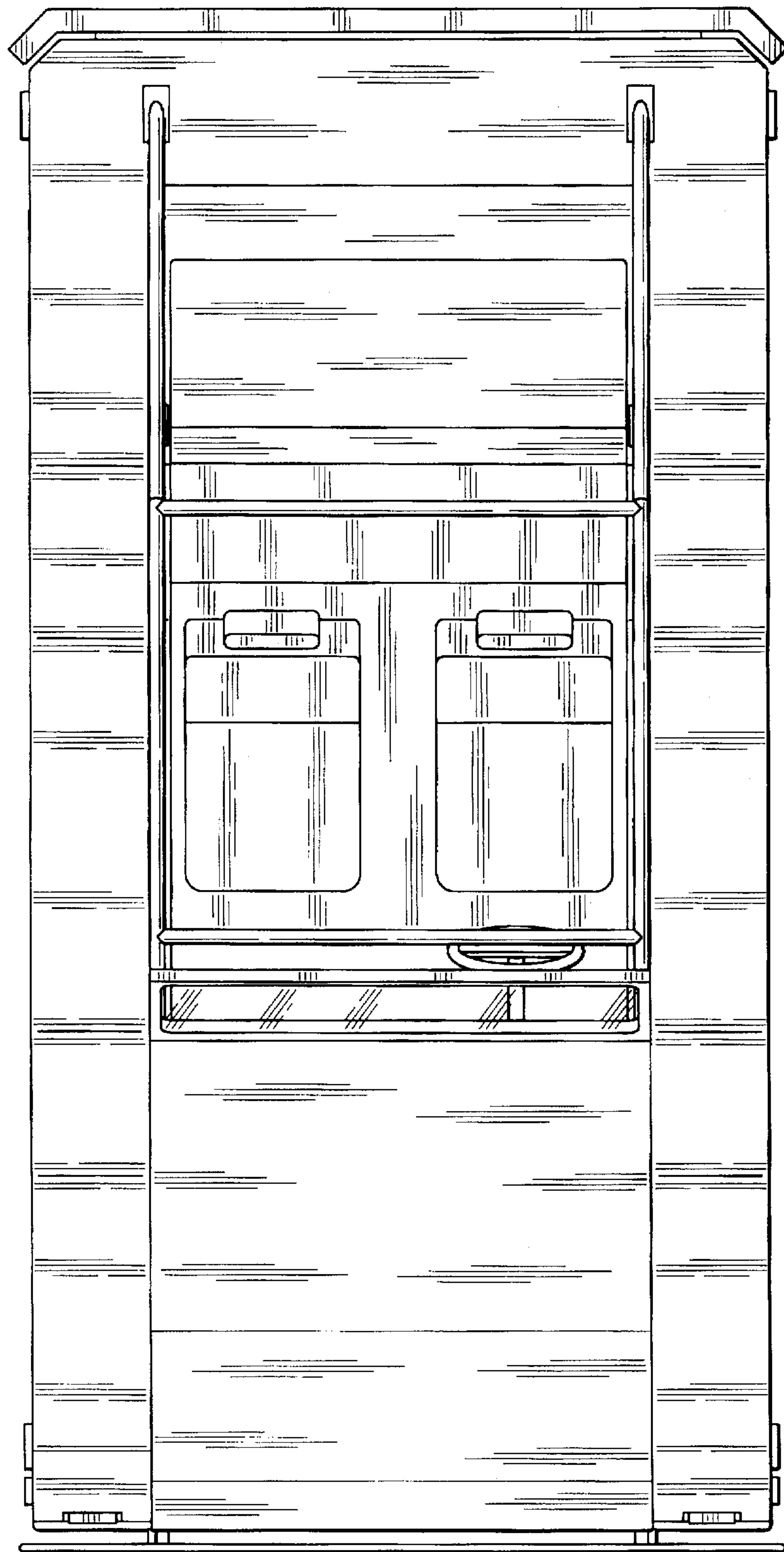
*Fig. 2*



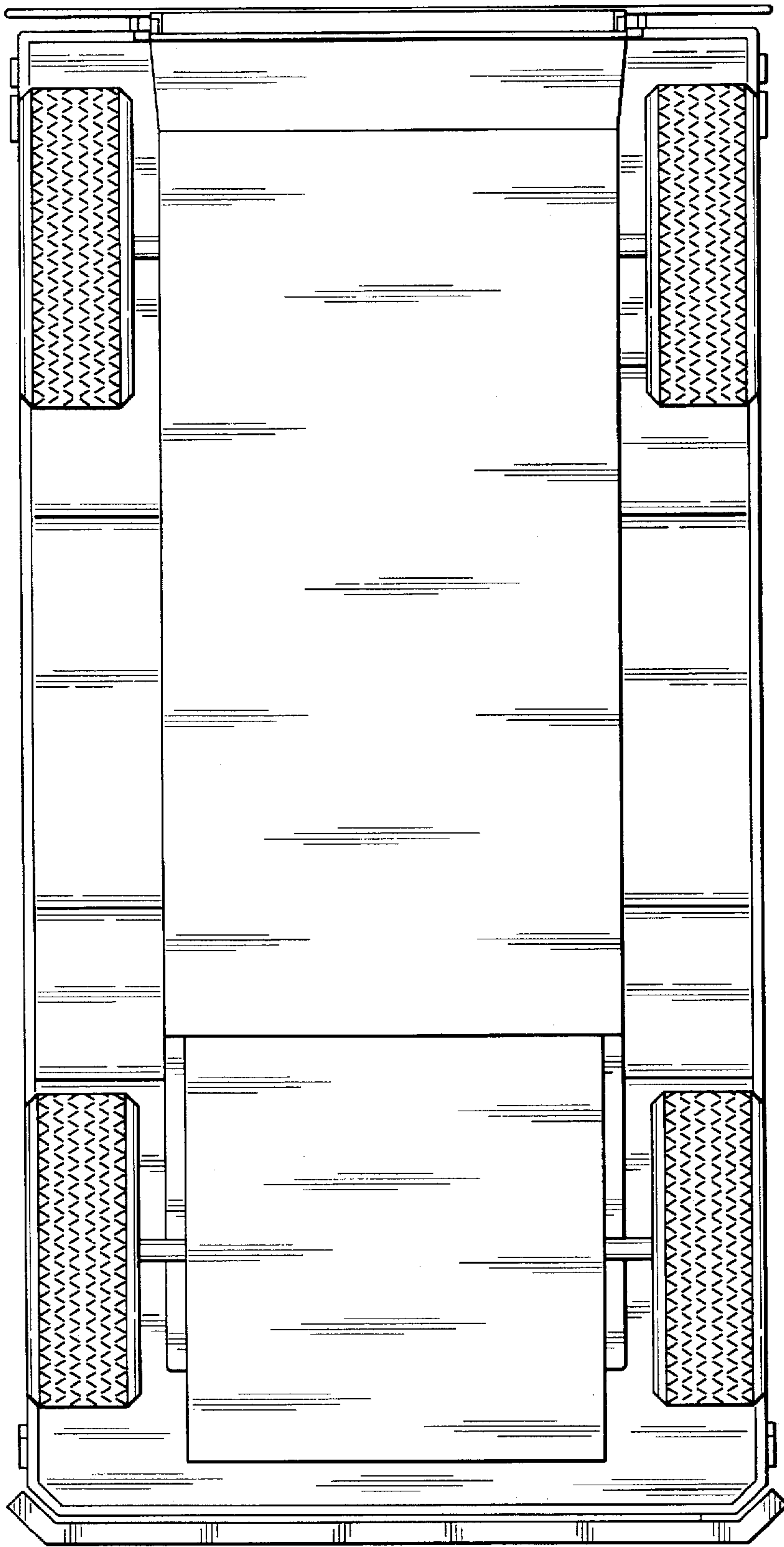
*Fig. 3*



*Fig. 4*



*Fig. 5*



*Fig. 6*