

US00D393233S

United States Patent [19]
Emanuel

[11] **Patent Number:** **Des. 393,233**
[45] **Date of Patent:** ****Apr. 7, 1998**

[54] **COMBINED SLED AND WAGON**
[76] **Inventor:** **Dorothy Emanuel, 6 Donna Dr.,
Edison, N.J. 08820**
[**] **Term:** **14 Years**
[21] **Appl. No.:** **31,143**
[22] **Filed:** **Nov. 18, 1994**
[51] **LOC (6) Cl.** **12-14**
[52] **U.S. Cl.** **D12/6**
[58] **Field of Search** **D12/6, 9, 11; 280/7.12,
280/7.14, 87.01**

4,337,957 7/1982 Heine 280/7.14
5,135,243 8/1992 Carpenter 280/7.14
5,176,395 1/1993 Garforth-Bles 280/415.1
5,222,748 6/1993 Johnson 280/8

Primary Examiner—Melody N. Brown

[57] **CLAIM**

The ornamental design for the combined sled and wagon, as shown and described.

DESCRIPTION

FIG. 1 is a front elevational view of the combined sled and wagon showing my new design;
FIG. 2 is a rear elevational view thereof;
FIG. 3 is a left side elevational view thereof;
FIG. 4 is a right side elevational view thereof;
FIG. 5 is a top plan view thereof;
FIG. 6 is a bottom plan view thereof;
FIG. 7 is a left side elevational view thereof with the wheels in the folded position; and,
FIG. 8 is a bottom plan view thereof with the wheels in the folded position.

[56] **References Cited**
U.S. PATENT DOCUMENTS

D. 302,958 8/1989 Skippee et al. D12/6
D. 317,734 6/1991 Cunha D12/11
D. 331,031 11/1992 Janoff D12/6
D. 347,407 5/1994 Dowell D12/6
4,098,519 7/1978 Reid, Jr. 280/87.01
4,191,391 3/1980 Dorlini 280/9
4,244,593 1/1981 Malone 280/87.01

1 Claim, 4 Drawing Sheets

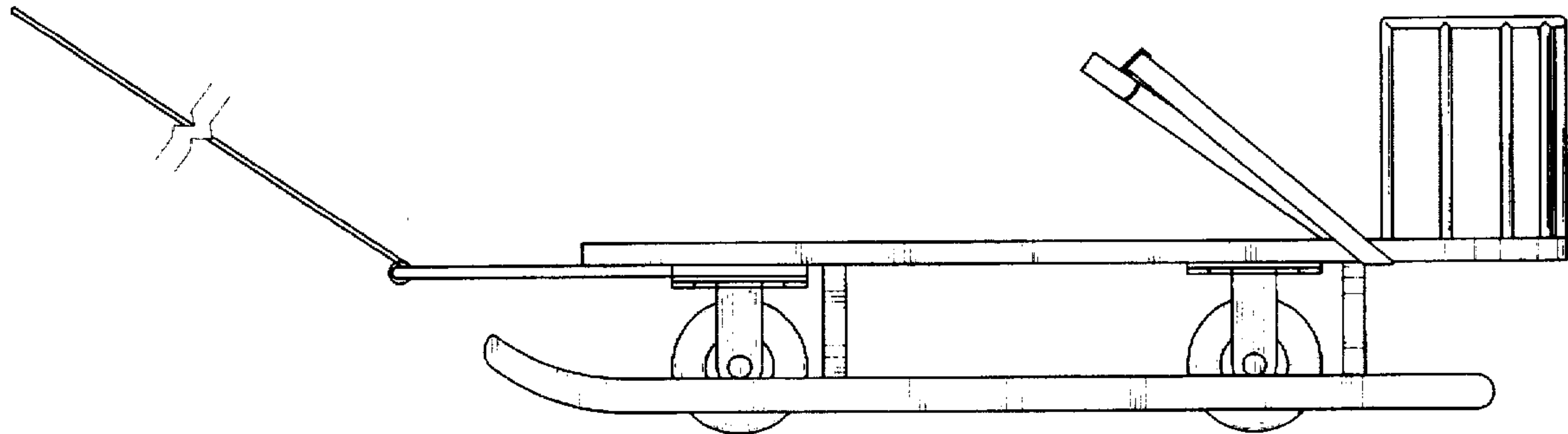

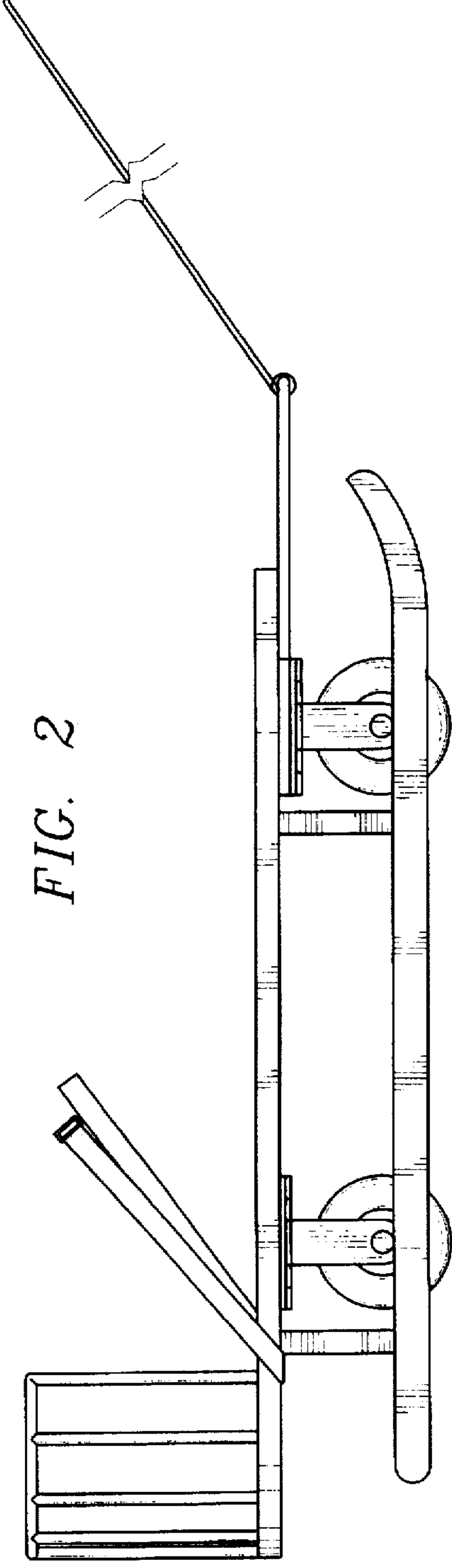
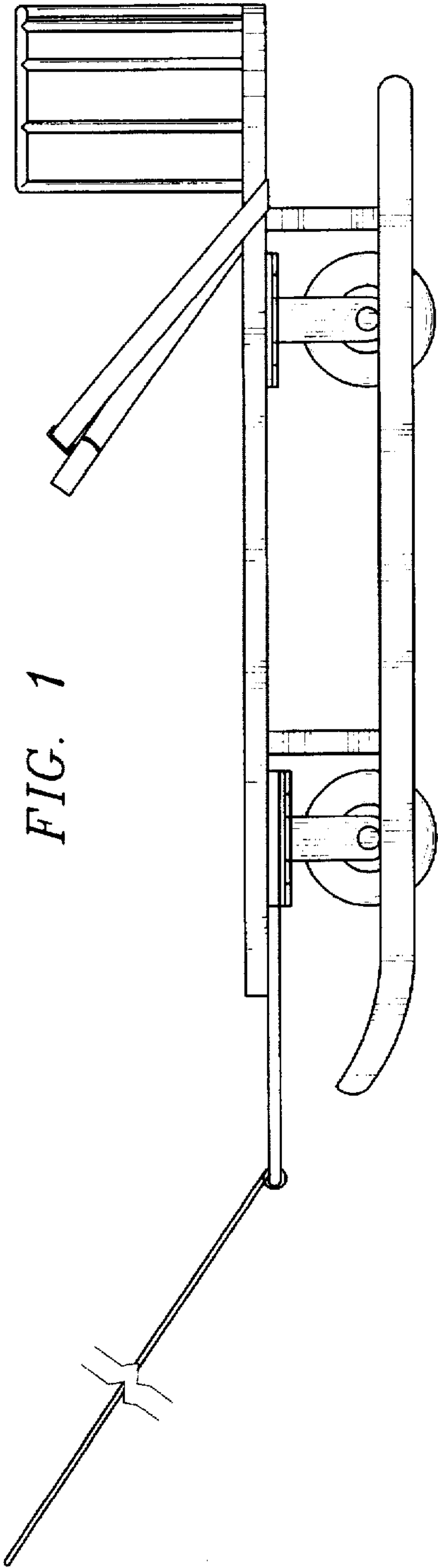

FIG. 3

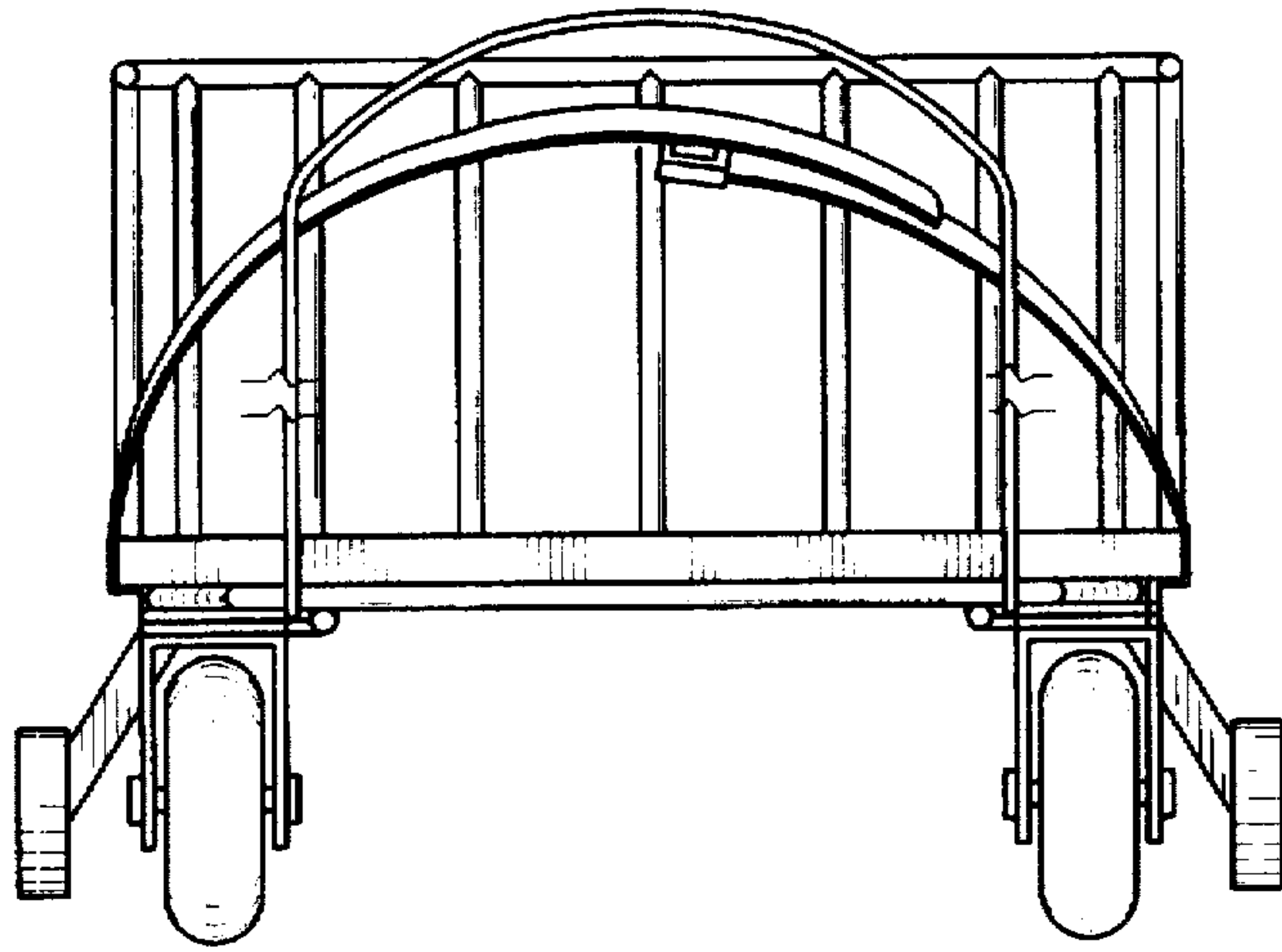
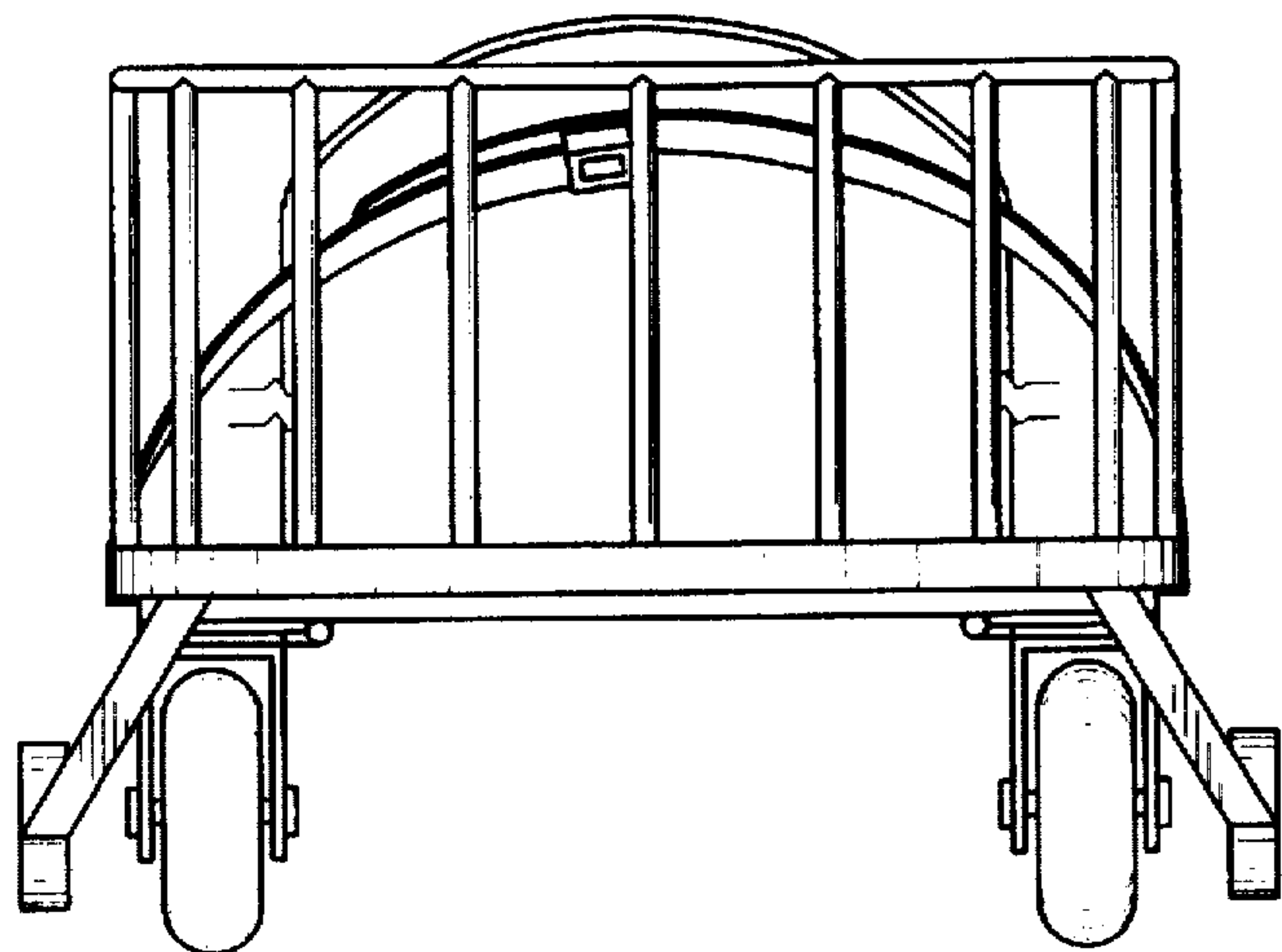

FIG. 4



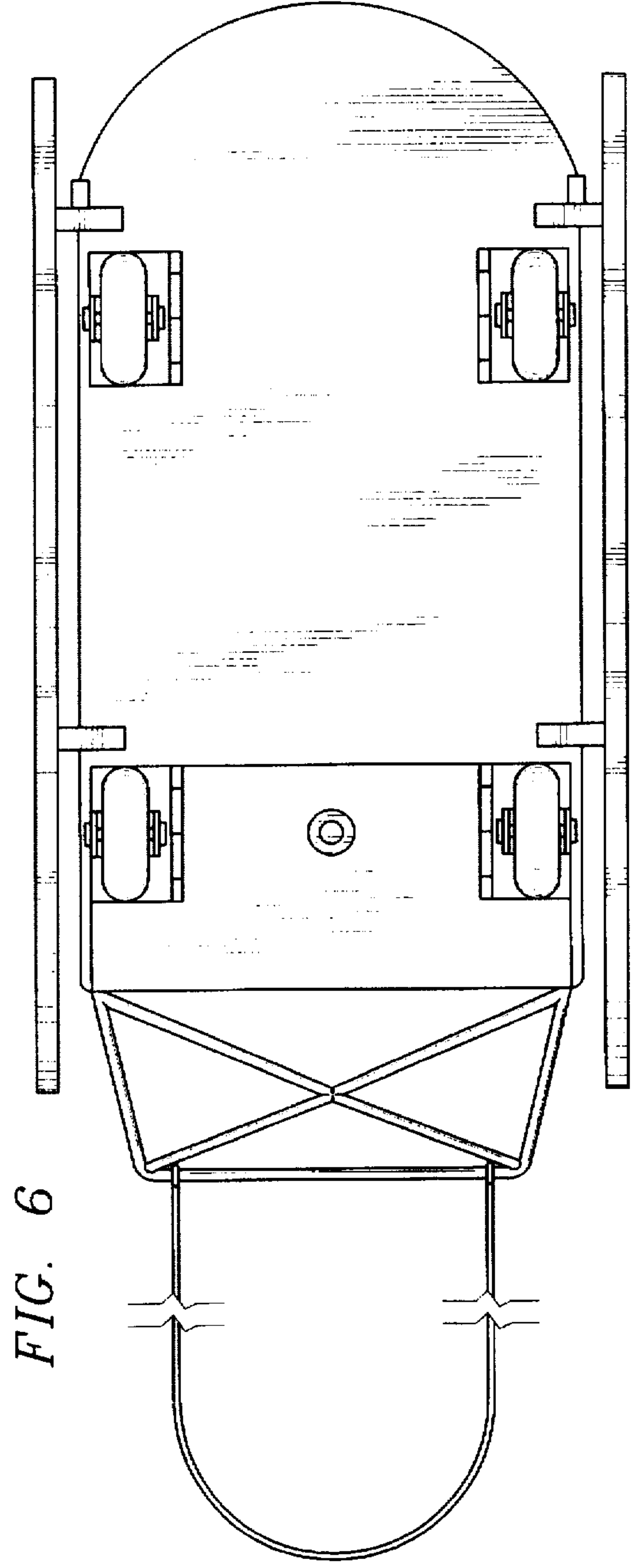
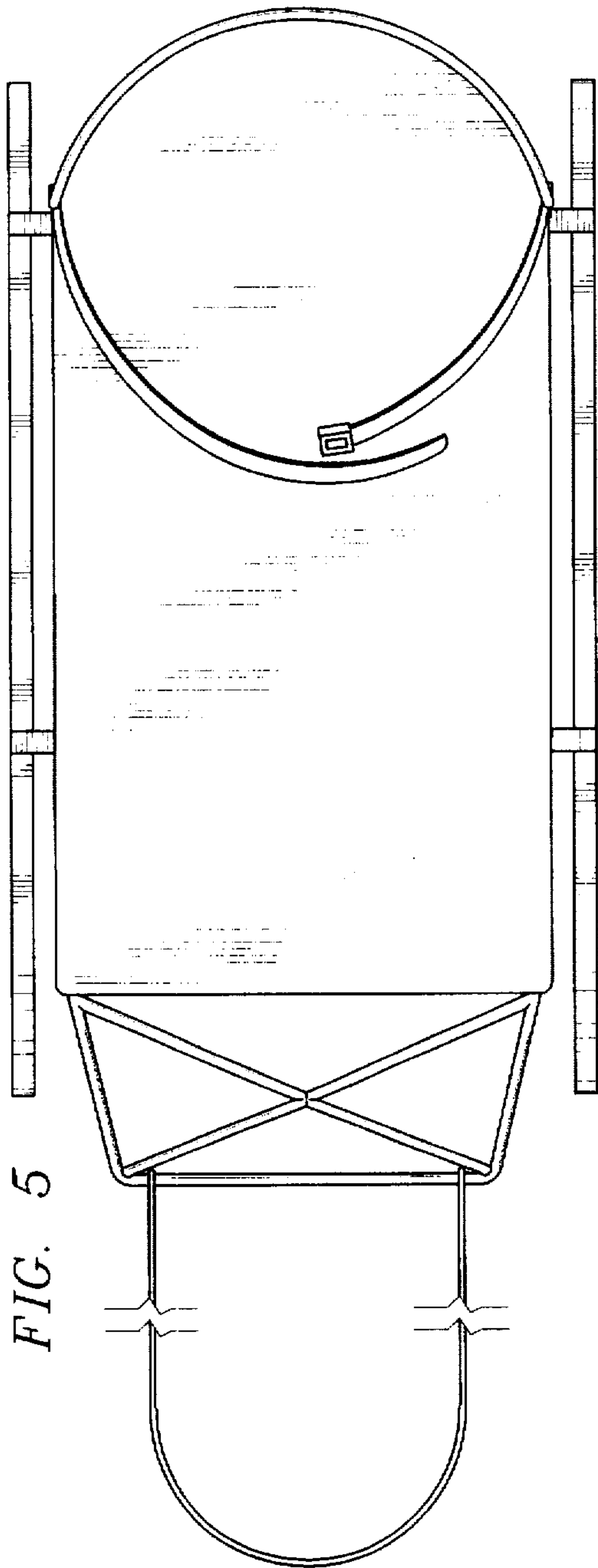

FIG. 7

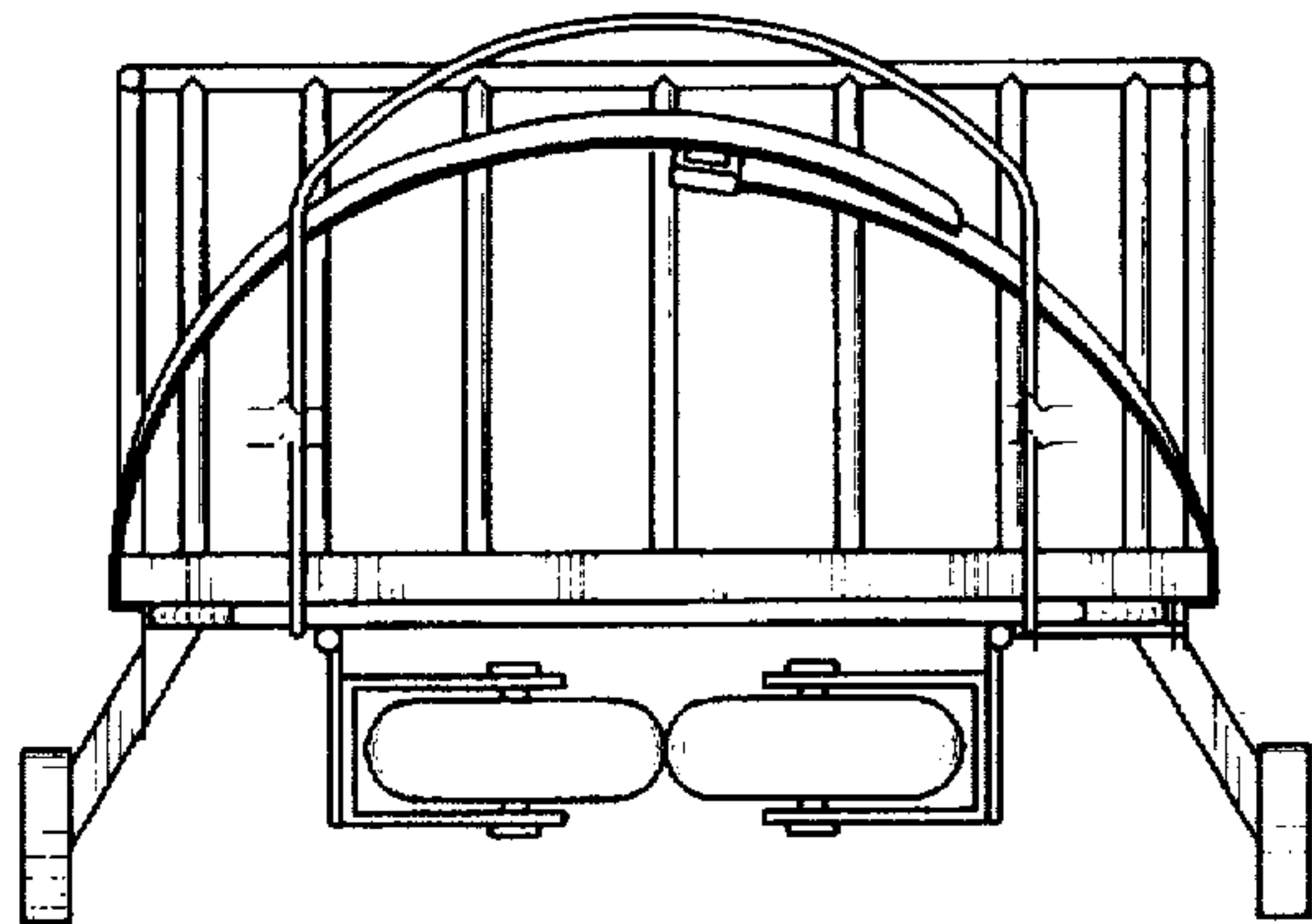

FIG. 8

