



US00D393038S

United States Patent [19]
Peterson

[11] **Patent Number: Des. 393,038**
[45] **Date of Patent: **Mar. 31, 1998**

[54] **AQUATIC VEHICLE**

5,090,930 2/1992 Walden 441/131
5,476,404 12/1995 Price 441/131

[75] **Inventor: Leroy L. Peterson, Omaha, Nebr.**

Primary Examiner—Kay H. Chin
Attorney, Agent, or Firm—Henderson & Sturm

[73] **Assignee: Sportsstuff, Inc., Omaha, Nebr.**

[**] **Term: 14 Years**

[57] **CLAIM**

[21] **Appl. No.: 66,822**

The ornamental design for an aquatic vehicle, as shown and described.

[22] **Filed: Feb. 20, 1997**

DESCRIPTION

[51] **LOC (6) Cl. 12-06**

[52] **U.S. Cl. D21/237**

[58] **Field of Search D21/236-238;**
D12/316; 441/66, 67, 88, 113-116, 127-131,
136; 482/111

FIG. 1 is a front perspective view of an aquatic vehicle showing my new design, wherein the broken lines depict the aft end of a motor boat for environmental purposes only and form no part of the claimed design;

FIG. 2 is a left side elevational view thereof;

FIG. 3 is a right side elevational view thereof;

FIG. 4 is a front elevational view thereof;

FIG. 5 is a rear elevational view thereof;

FIG. 6 is a top plan view thereof; and,

FIG. 7 is a bottom plan view thereof.

[56] **References Cited**

U.S. PATENT DOCUMENTS

D. 340,495 10/1993 Mitch et al. D21/237
D. 377,821 2/1997 Kuan D21/237
4,601,667 7/1986 Hull 441/131

1 Claim, 2 Drawing Sheets

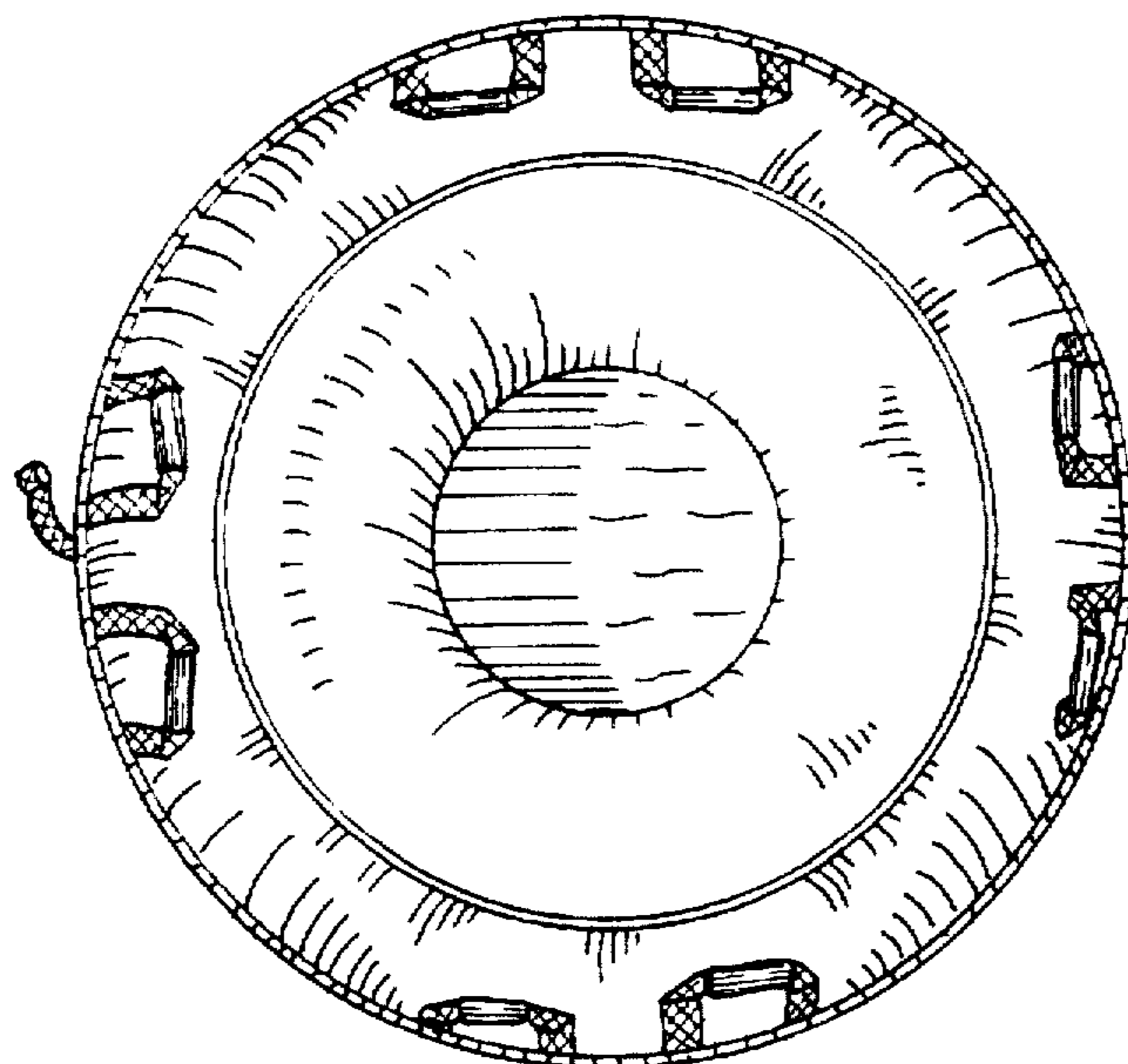
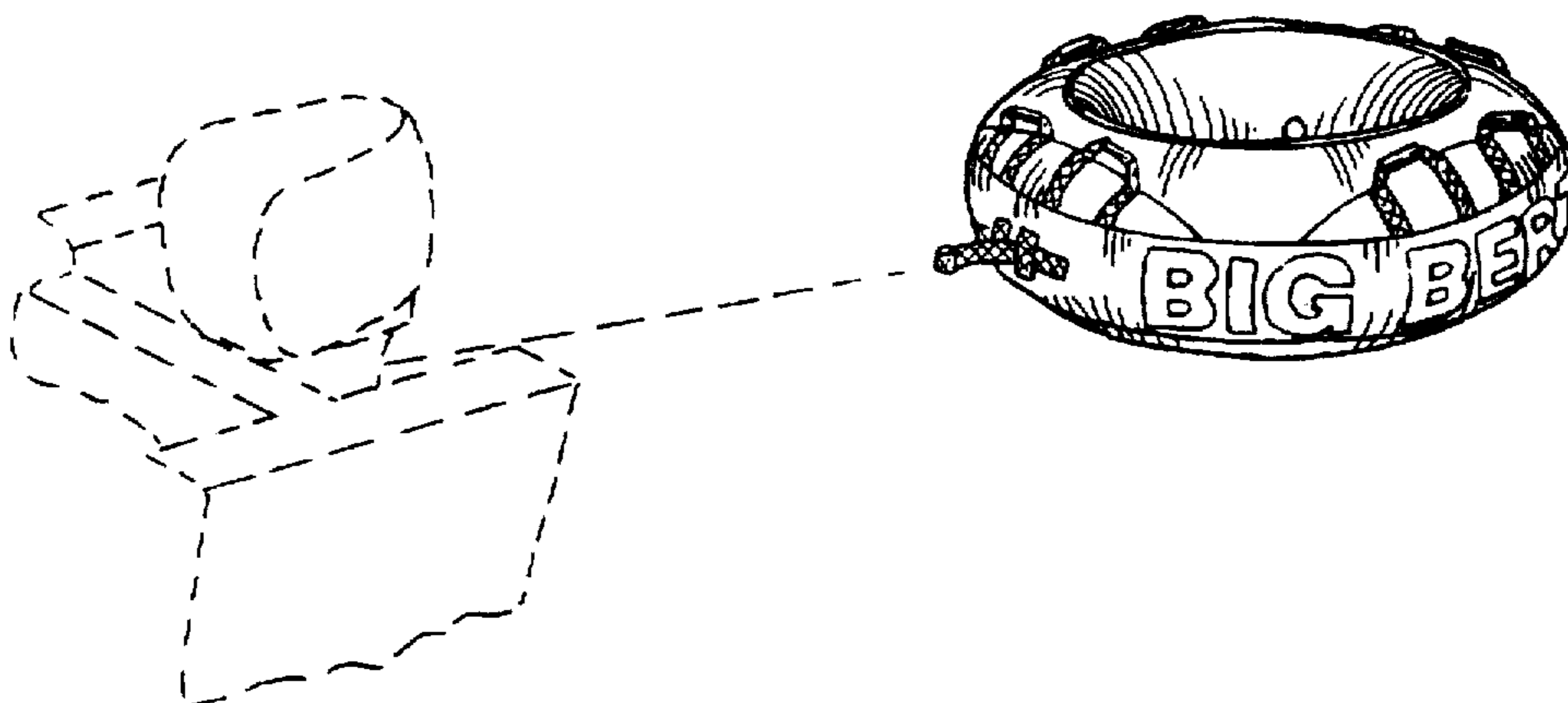

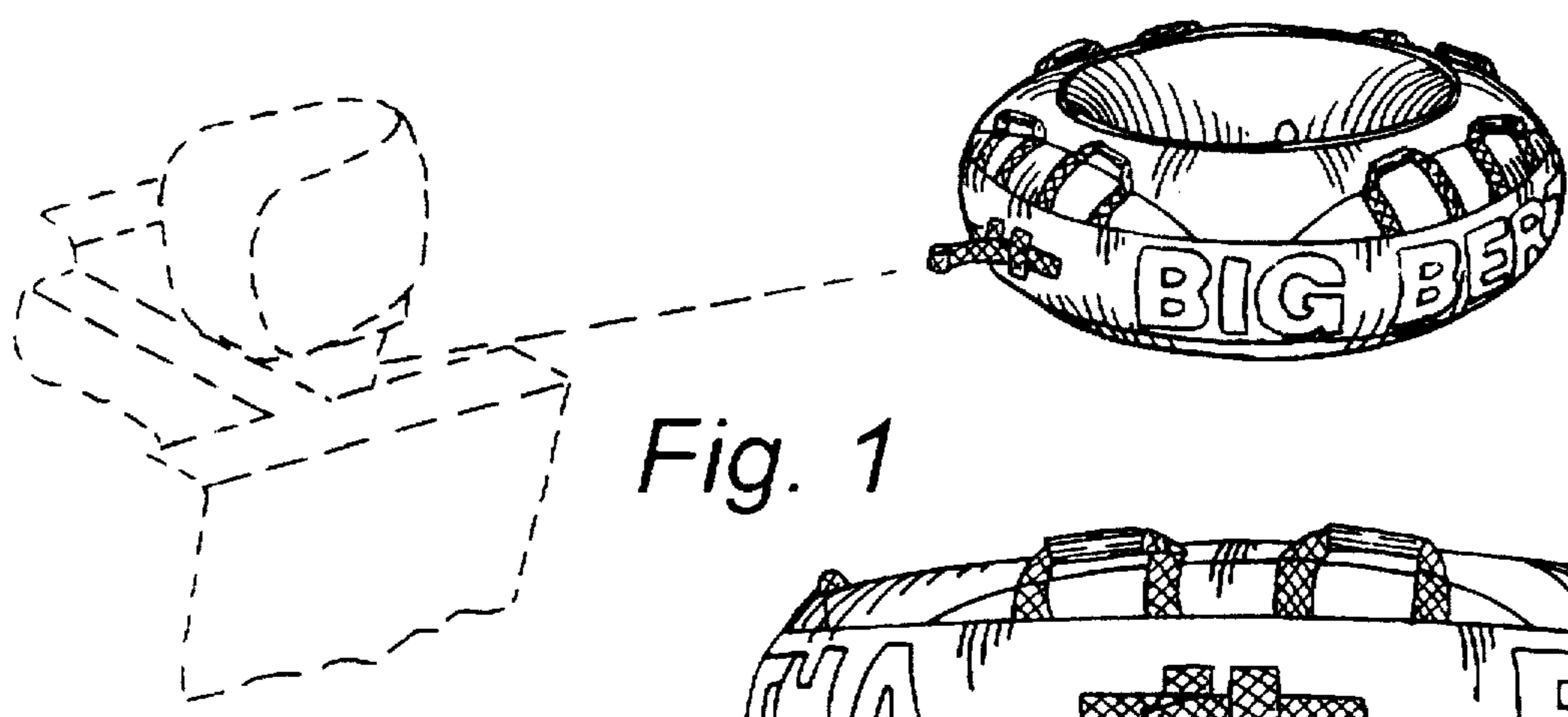

Fig. 1

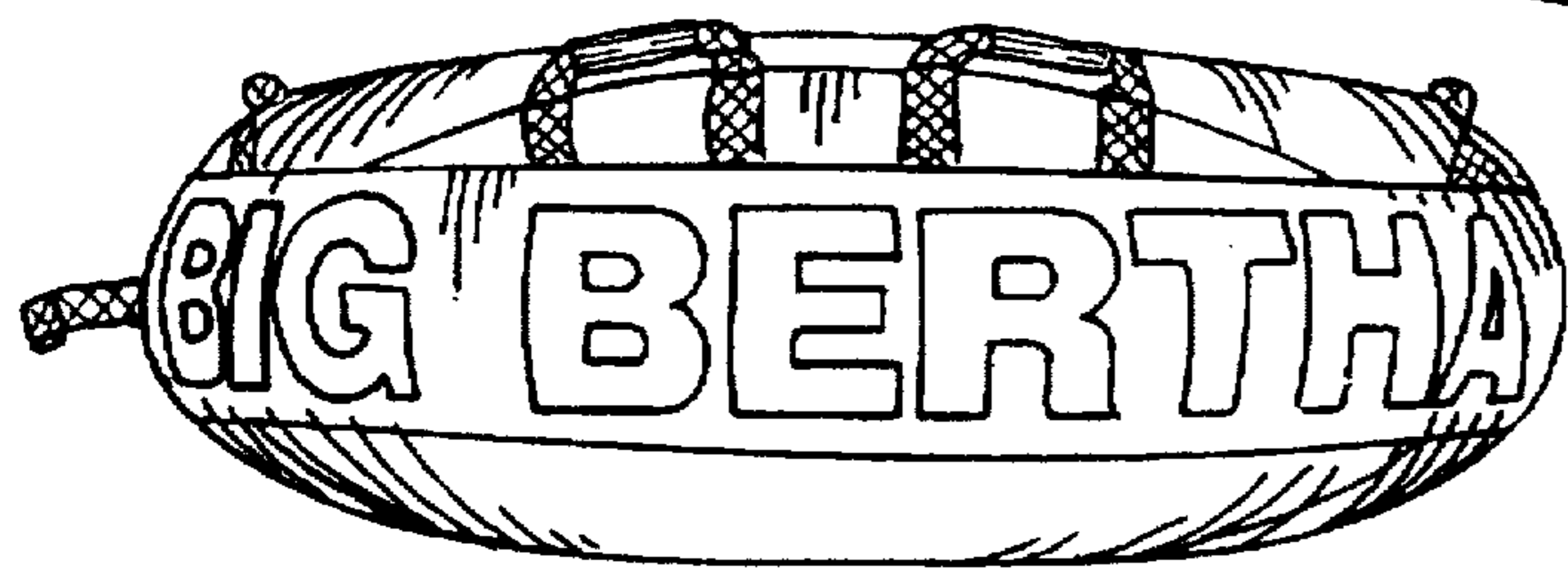
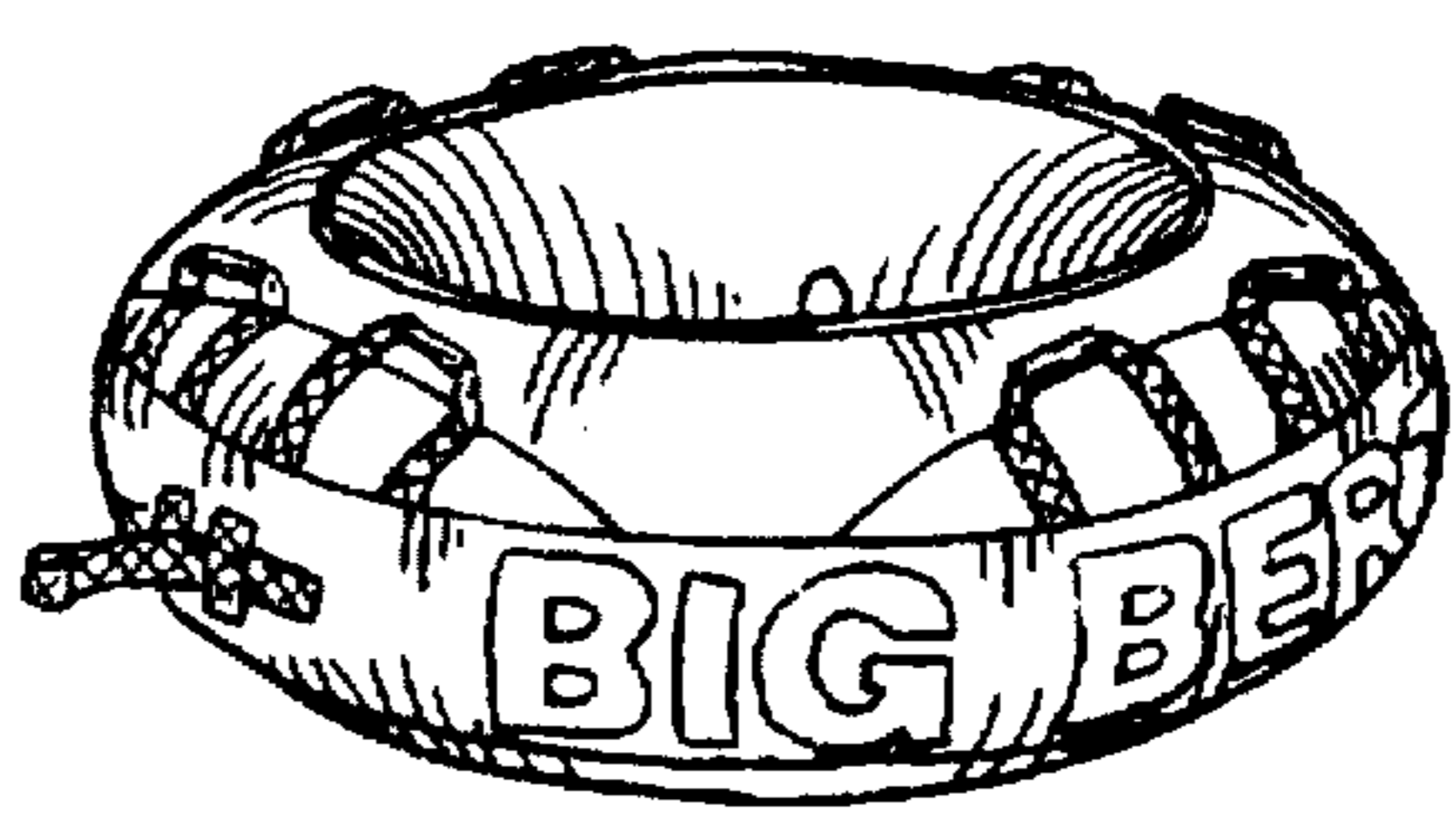

Fig. 2

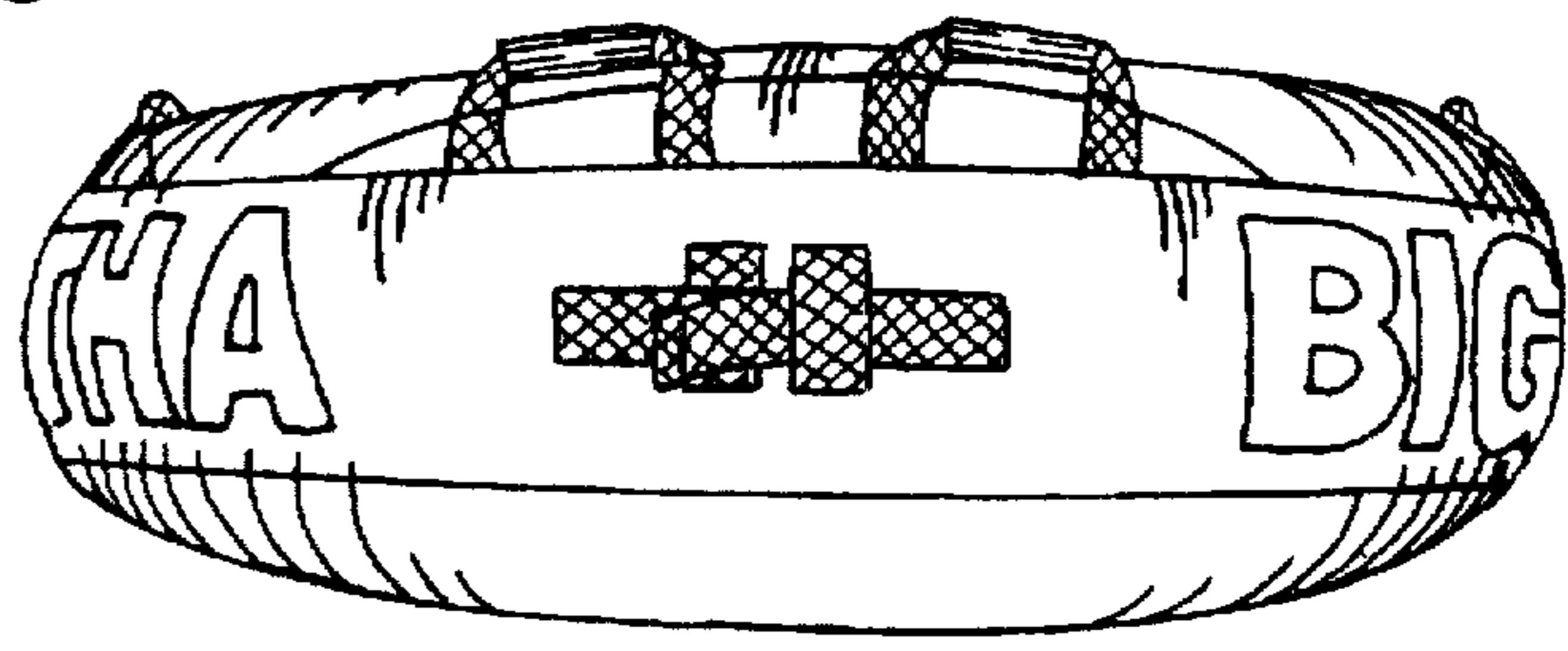

Fig. 4

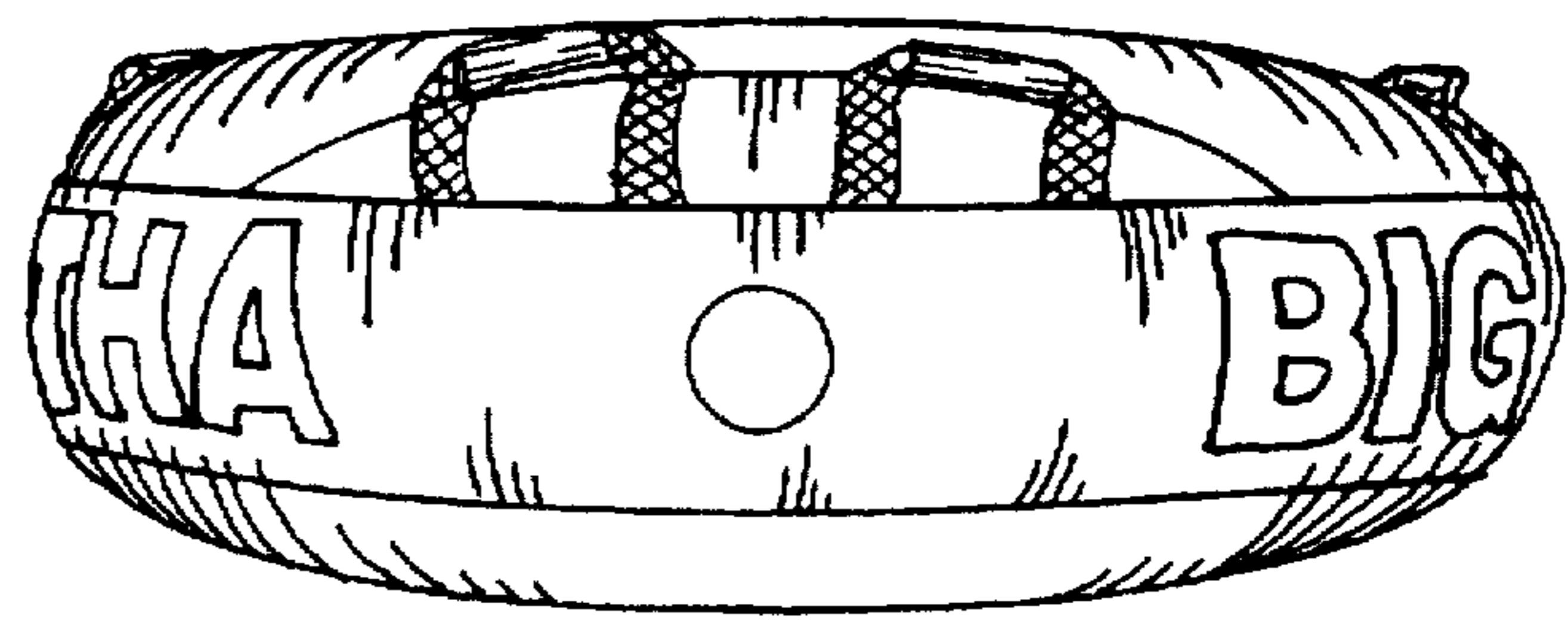

Fig. 5

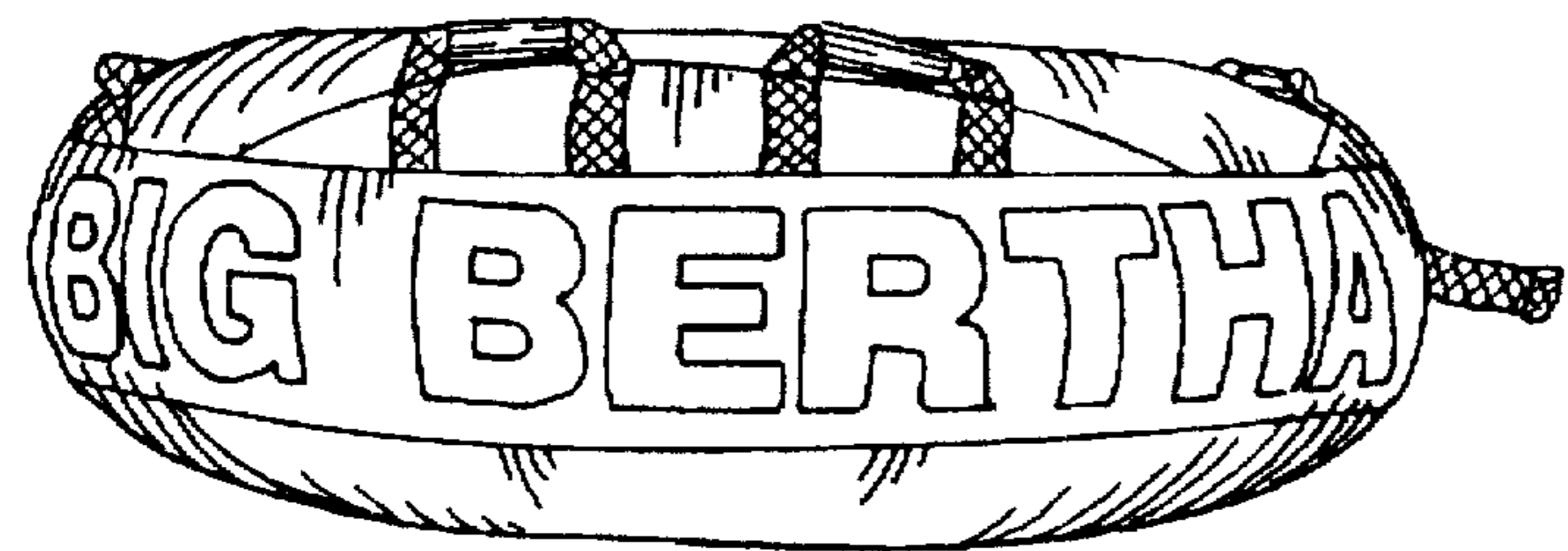

Fig. 3

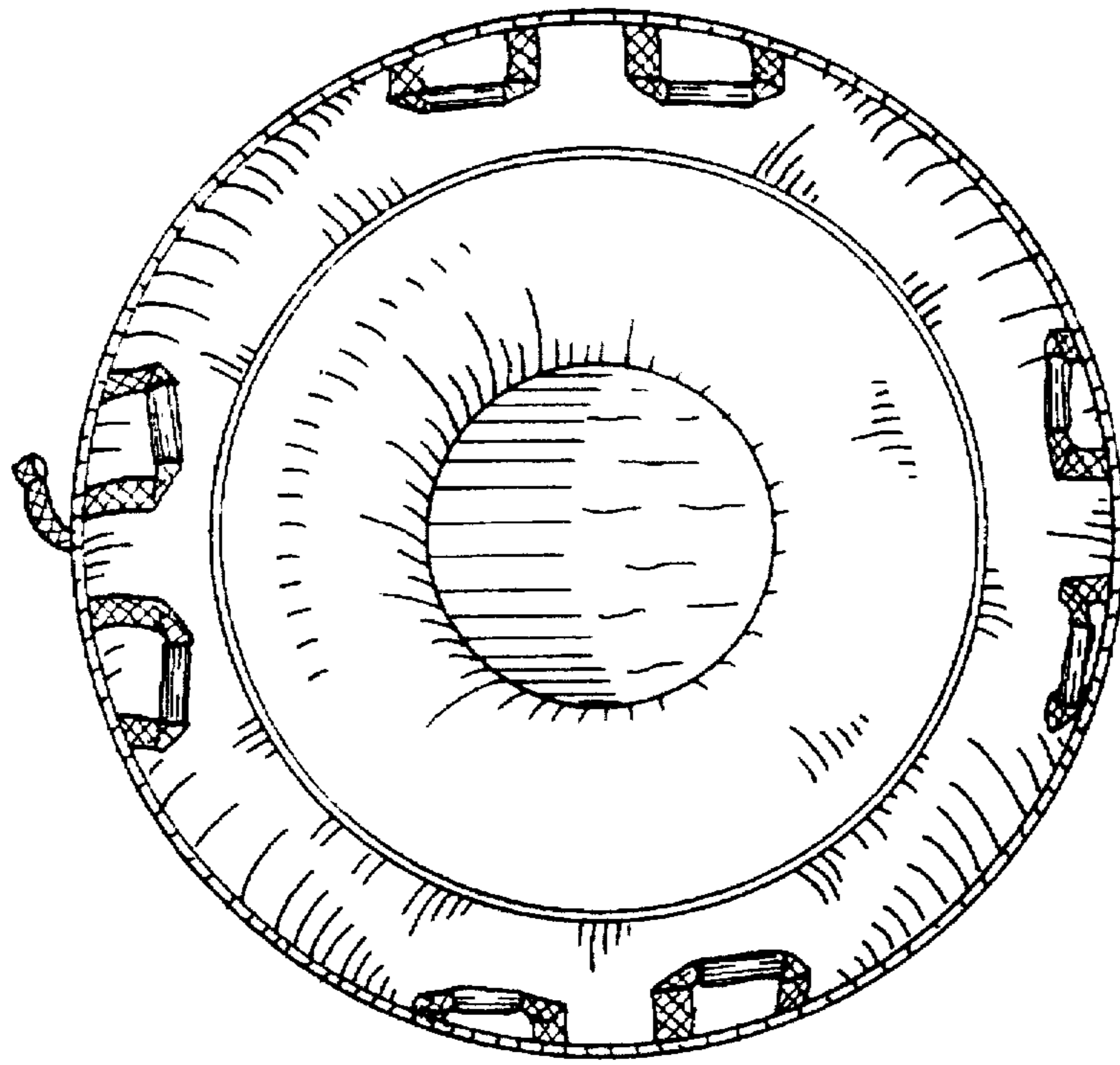

Fig. 6

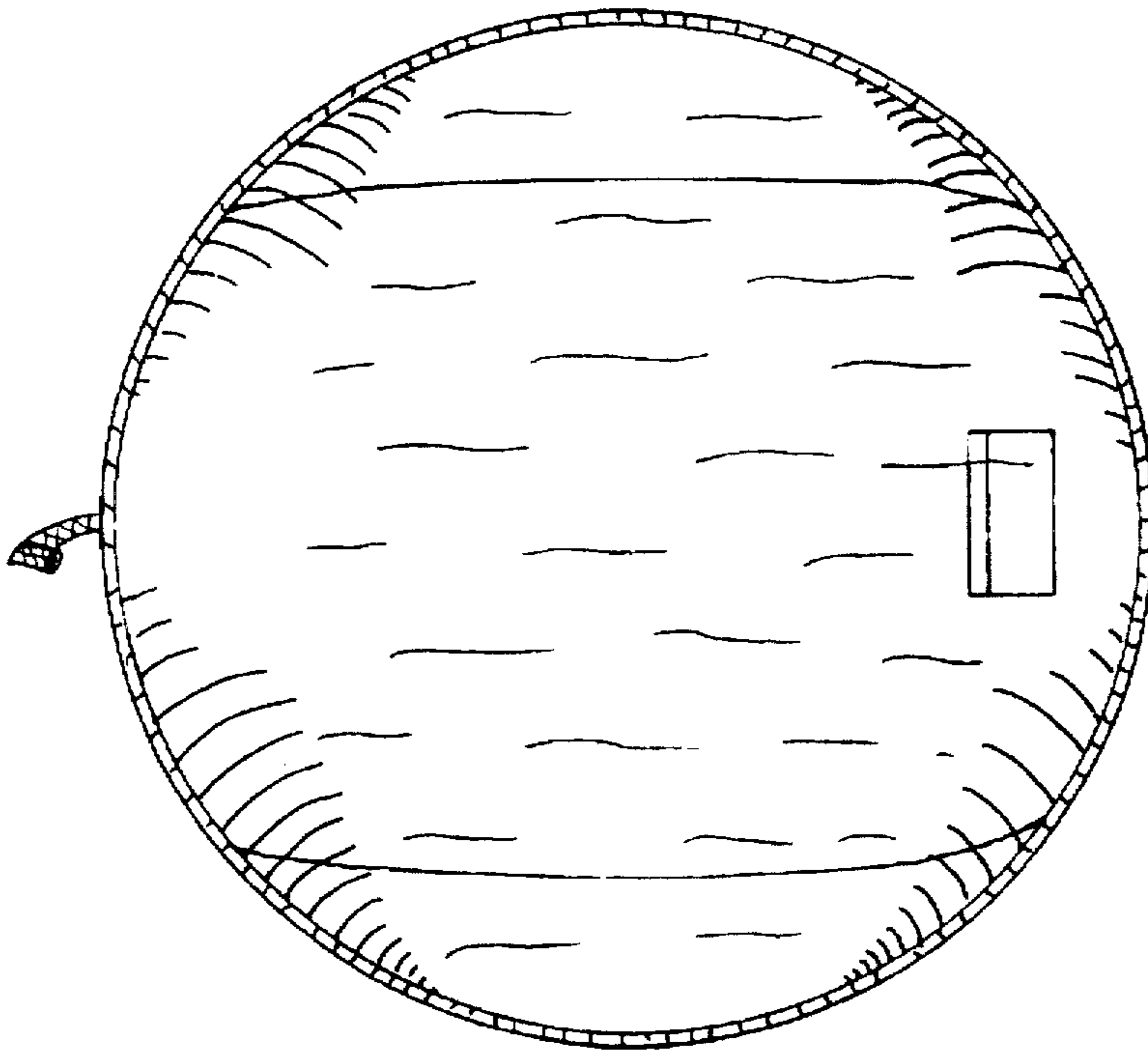

Fig. 7