

US00D392993S

United States Patent [19]
Oaks

[11] **Patent Number: Des. 392,993**
[45] **Date of Patent: **Mar. 31, 1998**

[54] **GUITAR VIBRATO ASSEMBLY**

Attorney, Agent, or Firm—M. Alex Brown, Patent Attorney

[76] **Inventor: Mark Oaks, Rte. 1, 3036 Hickory Valley Rd., Maynardville, Tenn. 37807**

[57] **CLAIM**

[**] **Term: 14 Years**

The ornamental design for a guitar vibrato assembly, as shown and described.

[21] **Appl. No.: 39,808**

DESCRIPTION

[22] **Filed: May 30, 1995**

Related U.S. Application Data

[63] **Continuation-in-part of Ser. No. 7,963, May 6, 1993, abandoned.**

FIG. 1 is a top plan view of a guitar vibrato assembly showing my new design;

[51] **LOC (6) Cl. 17-03**

FIG. 2 is a bottom plan view thereof;

[52] **U.S. Cl. D17/21**

FIG. 3 is a front elevational view thereof;

[58] **Field of Search D17/14, 18, 19, D17/20, 21; 84/267, 298, 299, 313, 314**

FIG. 4 is a rear elevational view thereof;

[56] **References Cited**

U.S. PATENT DOCUMENTS

D. 196,530	10/1963	Ormston	D17/21
D. 262,292	12/1981	Carson	D17/21
D. 268,845	5/1983	Fender	D17/21
D. 304,341	10/1989	Gressett, Jr. et al.	D17/21
D. 324,693	3/1992	Rose	D17/21
4,632,005	12/1986	Steinberger	84/313

FIG. 5 is a top, front and side perspective view thereof;

FIG. 6 is a top, rear and side perspective view thereof;

FIG. 7 is a right side view of the design as seen from FIG. 1;

FIG. 8 is a left side view of the design as seen from FIG. 1;

FIG. 9 is a top perspective view thereof;

FIG. 10 is an enlarged partially exploded left side perspective view of the vibrato collar member shown for clarity of illustration; and,

FIG. 11 is an enlarged partially exploded, left side perspective view of the vibrato handle member shown for clarity of illustration.

OTHER PUBLICATIONS

The Music Trades, Nov. 1985 p. 48 (Kahler Tremolo).

Primary Examiner—Raphael Barkai
Assistant Examiner—Adir Aronovich

1 Claim, 10 Drawing Sheets

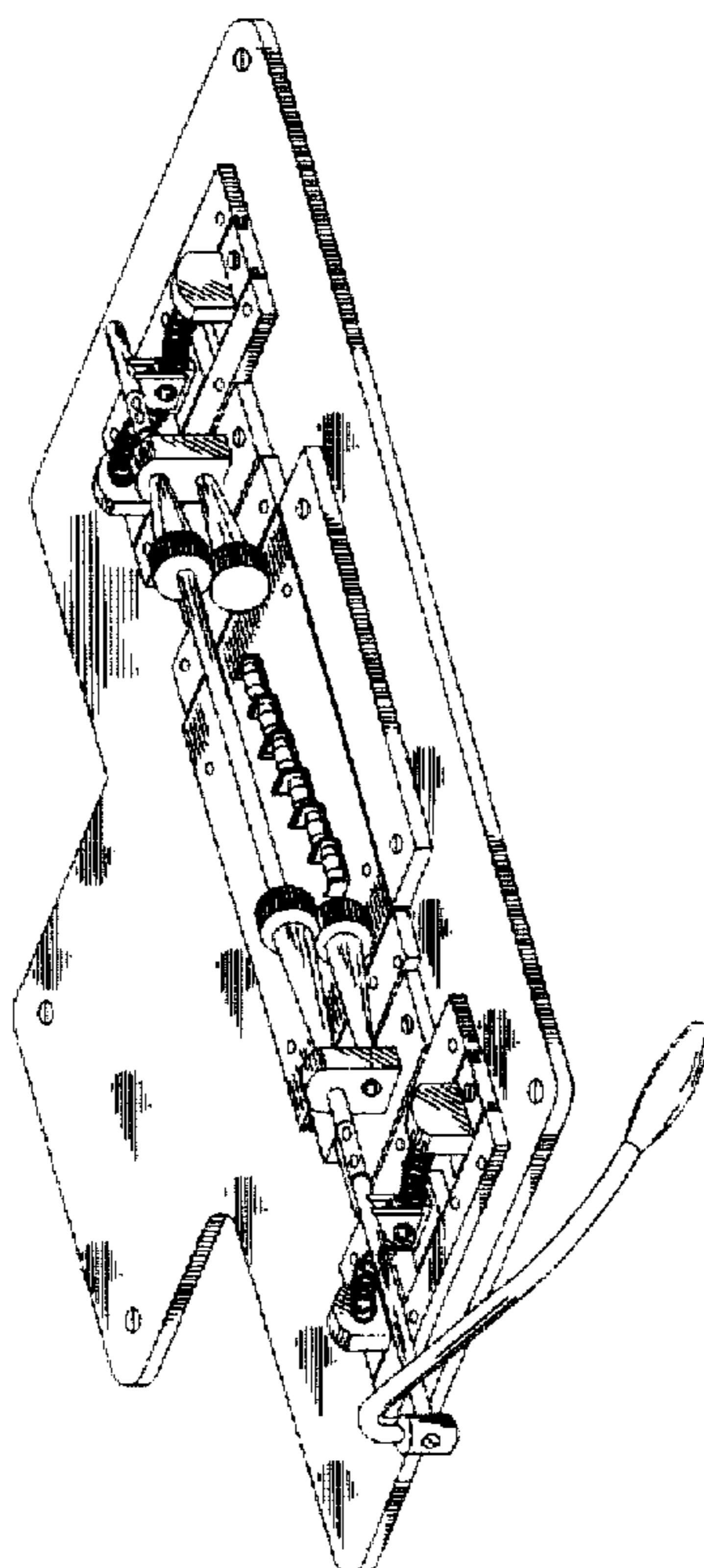

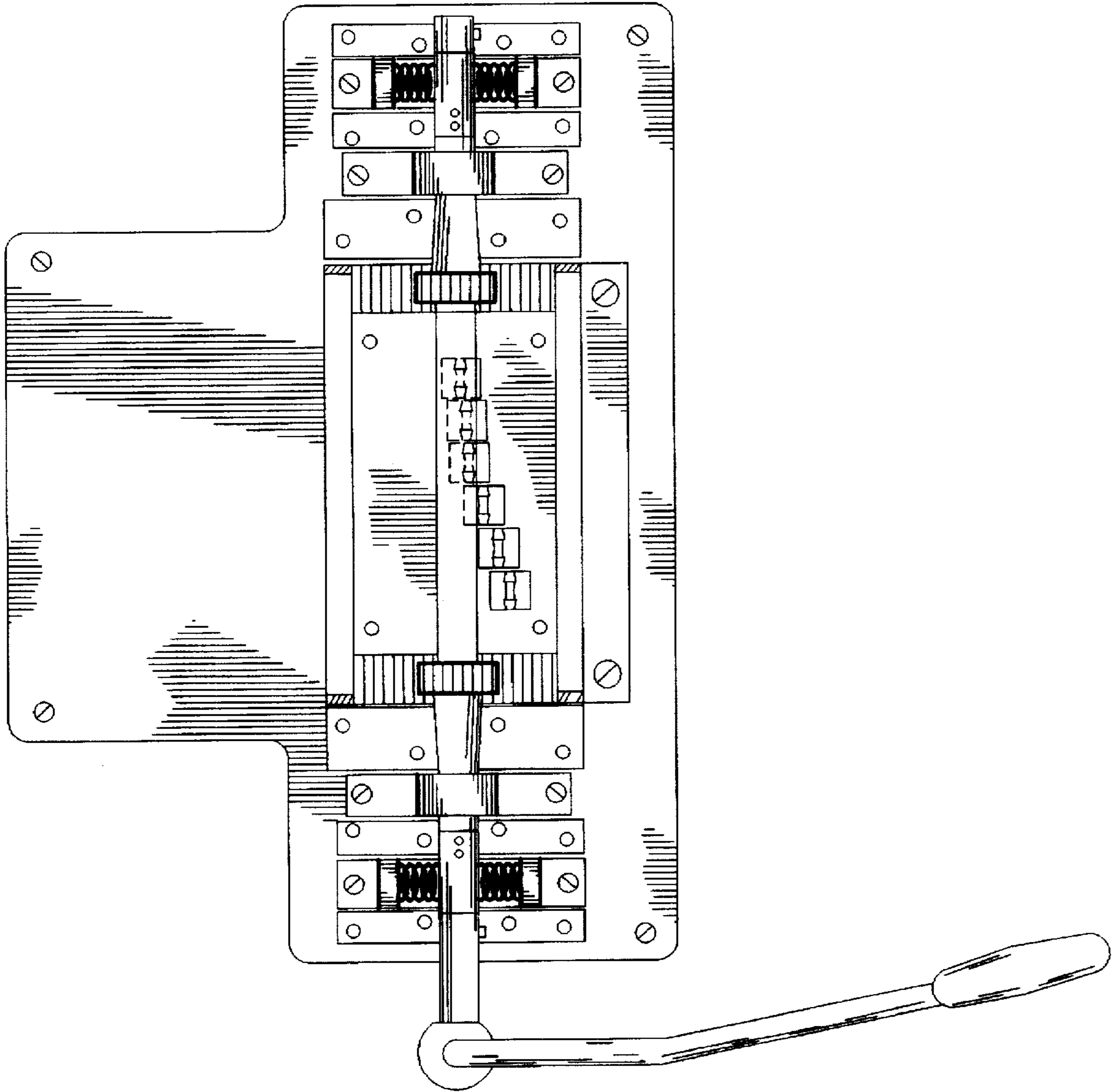

FIG. 1

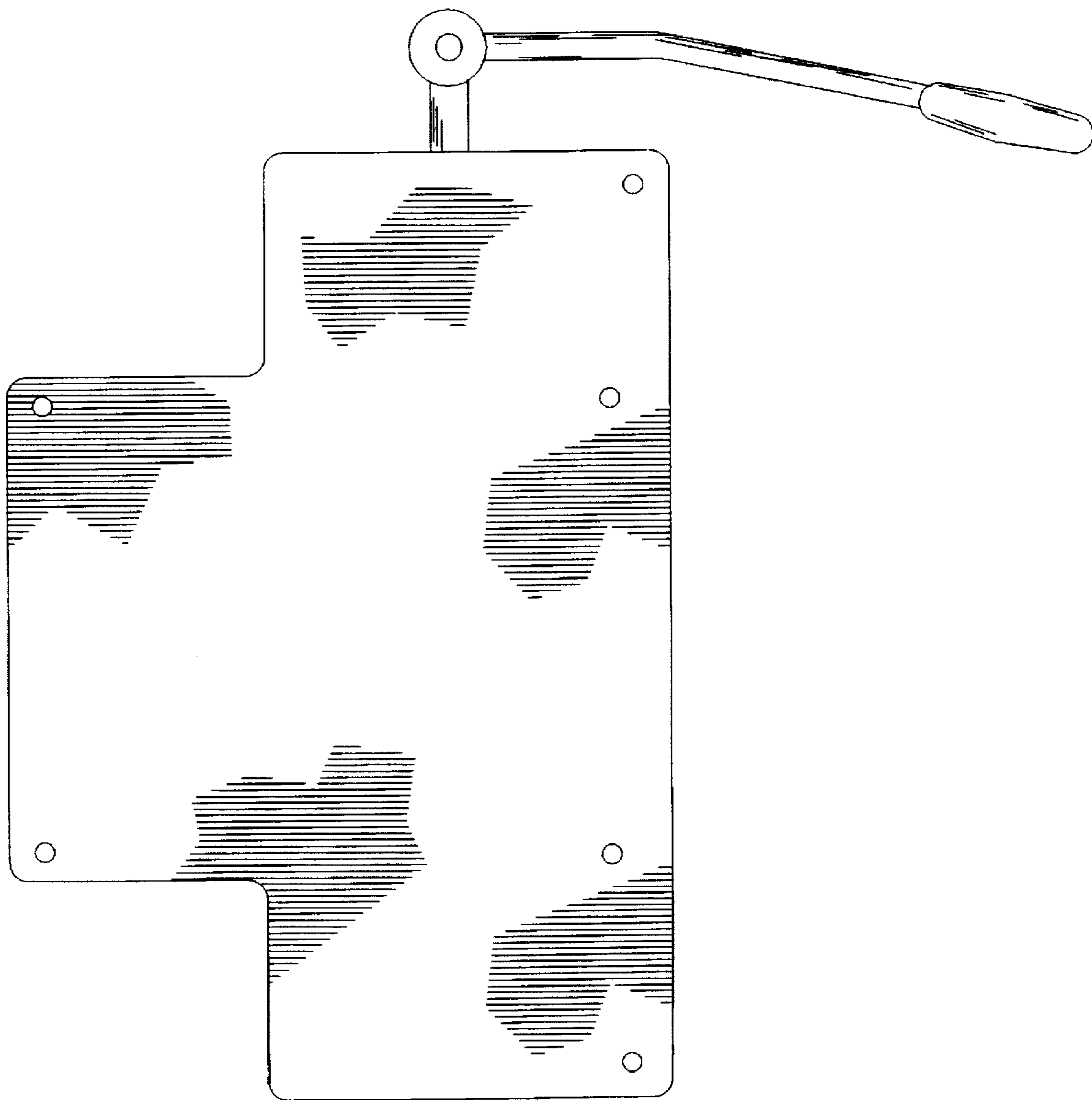

FIG. 2

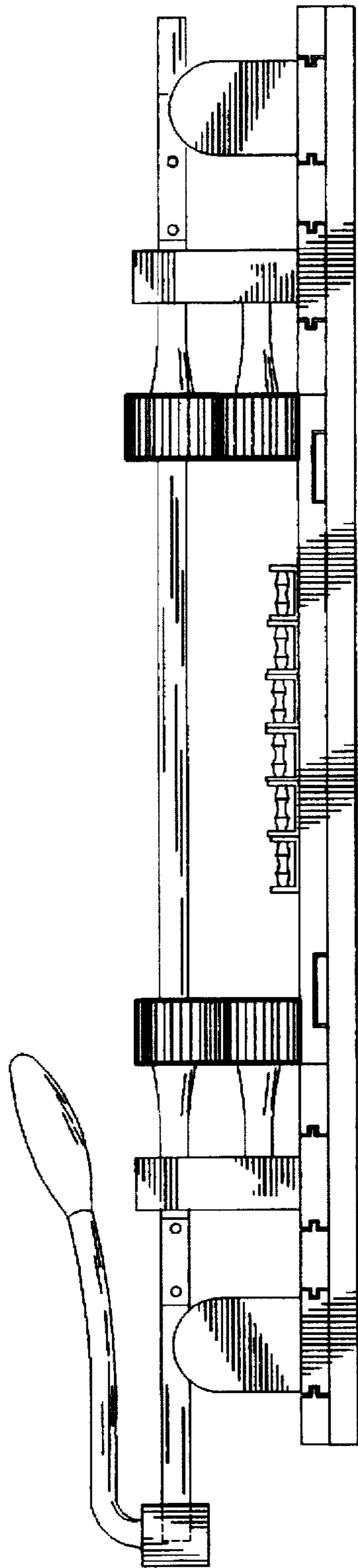

FIG. 3

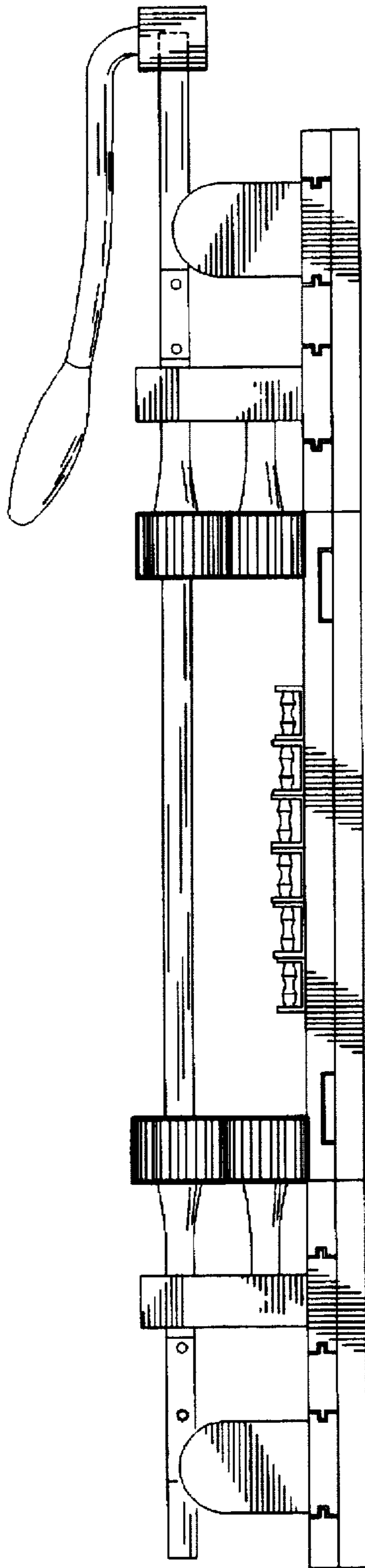

FIG. 4

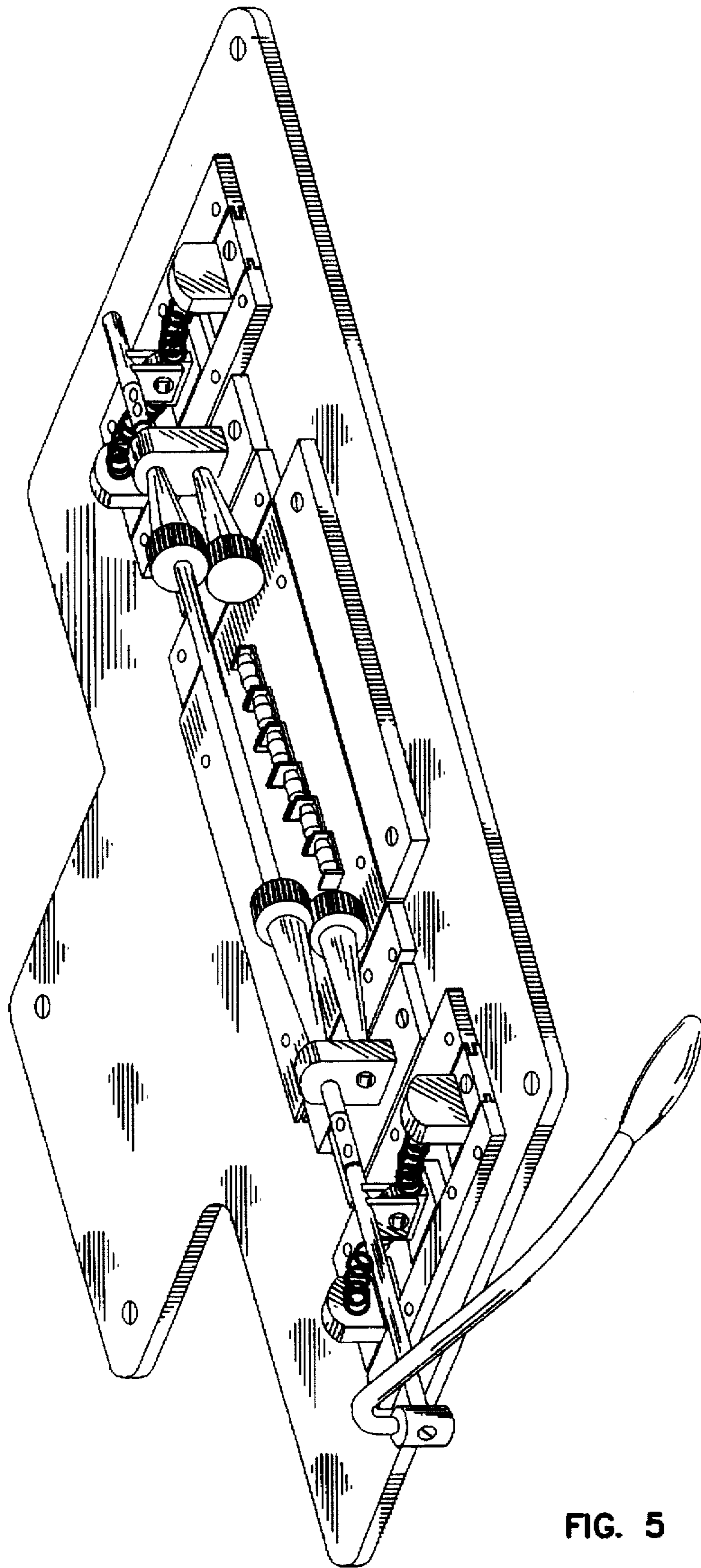

FIG. 5

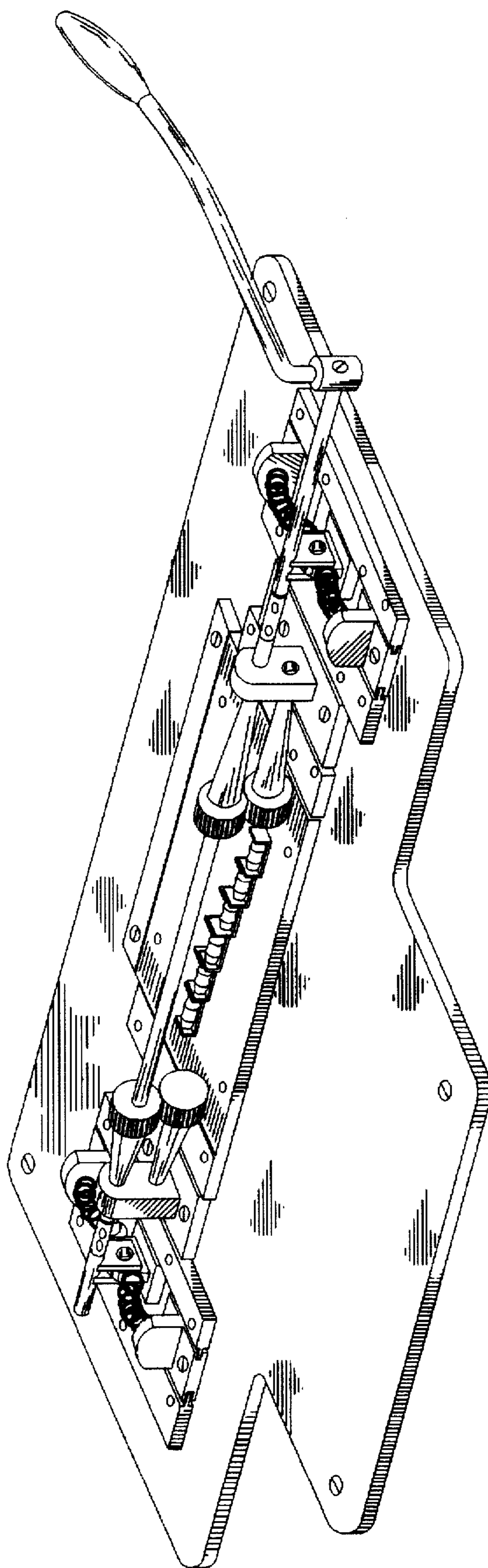

FIG. 6

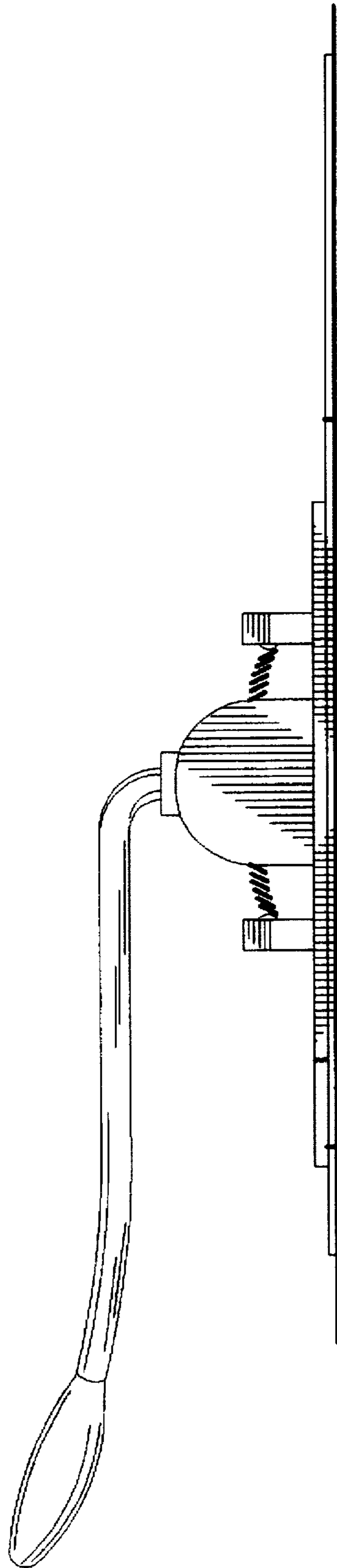

FIG. 7

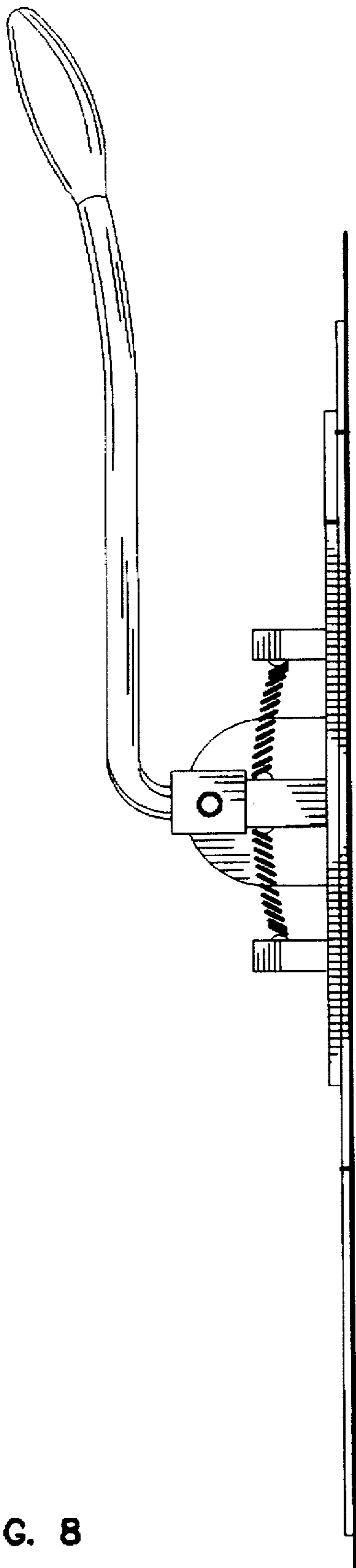

FIG. 8

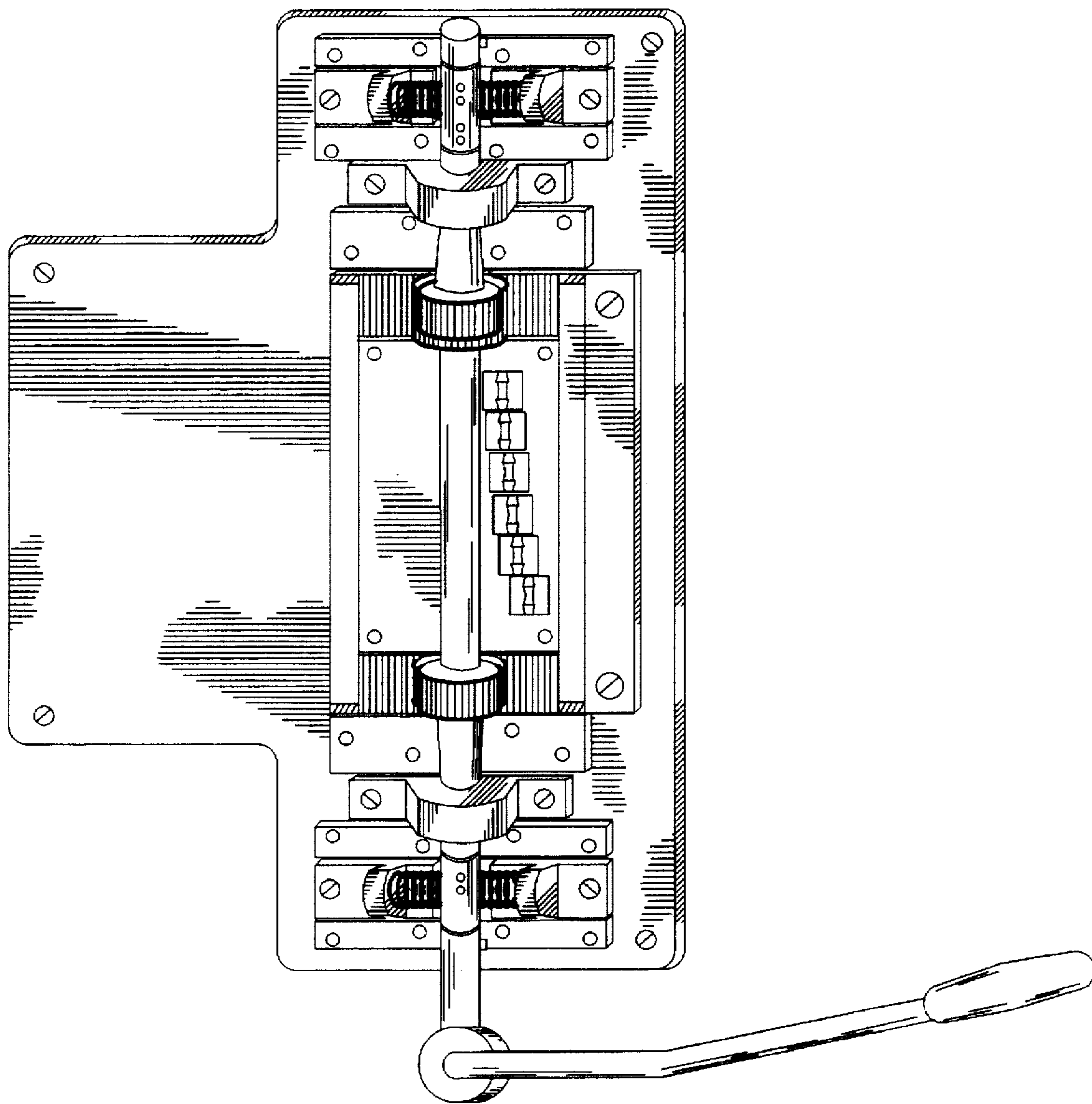

FIG. 9

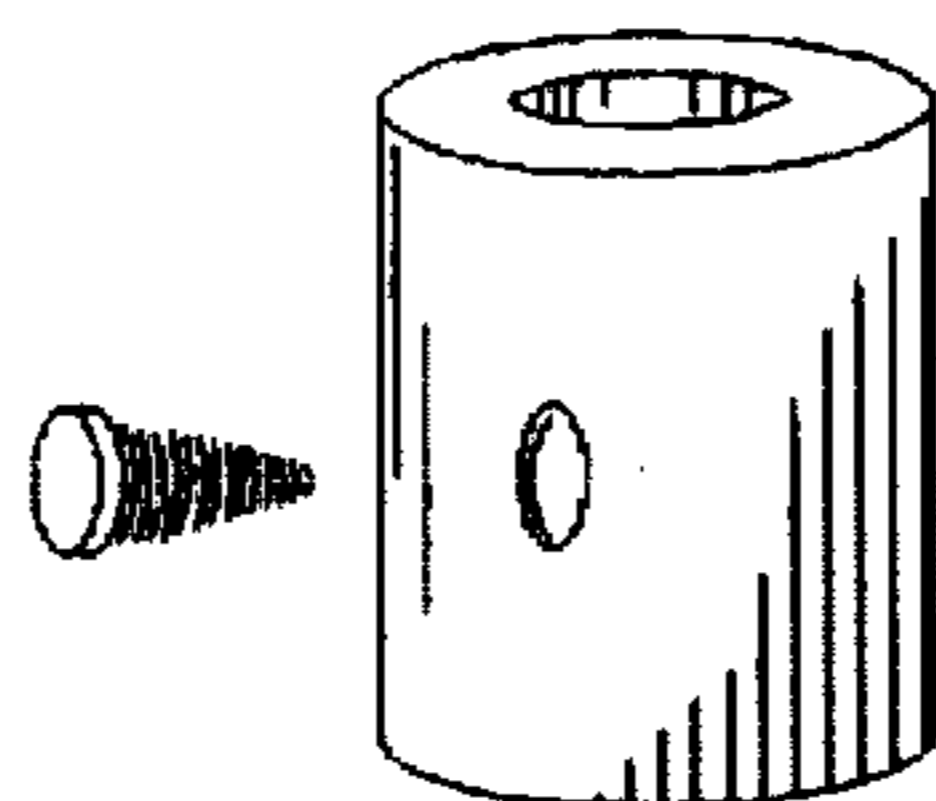

FIG. 10

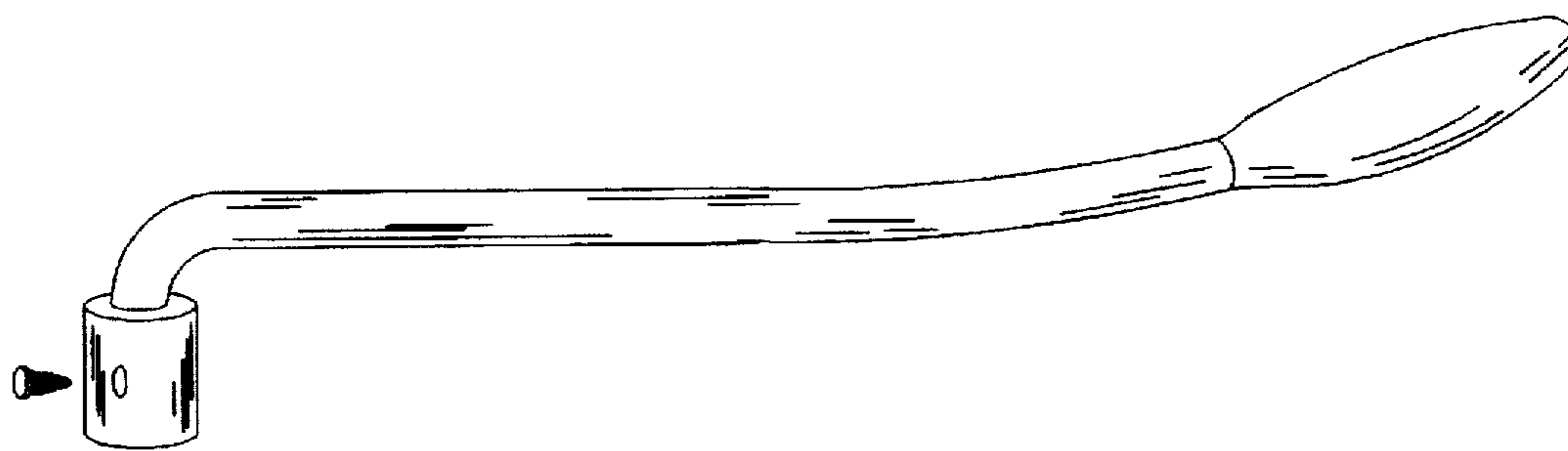

FIG. 11