



US00D392937S

United States Patent [19]

Brichard et al.

[11] Patent Number: Des. 392,937

[45] Date of Patent: **Mar. 31, 1998

[54] TWO SEATER AMPHIBIOUS AIRCRAFT

D. 325,021 3/1992 Mouton, Jr. D12/319
D. 337,751 7/1993 Silva D12/324

[75] Inventors: **Jean-Luc Brichard**, Balma; **Yves Gourinat**; **Gilbert Saint Blancat**, both of Toulouse; **Alain Vauvelle**, Pibrac, all of France

Primary Examiner—Kay H. Chin
Attorney, Agent, or Firm—Young & Thompson

[73] Assignee: **Aero Challenge**, Colomiers Cedex, France

[57] CLAIM

[**] Term: 14 Years

The ornamental design for a two seater amphibious aircraft, as shown and described.

[21] Appl. No.: 65,008

[22] Filed: Jan. 16, 1997

[30] Foreign Application Priority Data

Jul. 19, 1996 [FR] France 964263

[51] LOC (6) Cl. 12-07

[52] U.S. Cl. D12/324; D12/319

[58] Field of Search D12/319-345;
244/45 R, 23 R, 101, 106

DESCRIPTION

FIG. 1 is a top, front and side perspective view of a two seater amphibious aircraft, showing our new design;

FIG. 2 is a rear, bottom and side perspective view thereof;

FIG. 3 is a front elevational view thereof;

FIG. 4 is a side elevational view thereof from the right of FIG. 3, the side elevational view from the left of FIG. 3 being the mirror image thereof;

FIG. 5 is a rear elevational view thereof;

FIG. 6 is a top plan view thereof; and,

FIG. 7 is a bottom plan view thereof.

[56] References Cited

U.S. PATENT DOCUMENTS

D. 178,584 8/1956 Toth D12/324

1 Claim, 6 Drawing Sheets

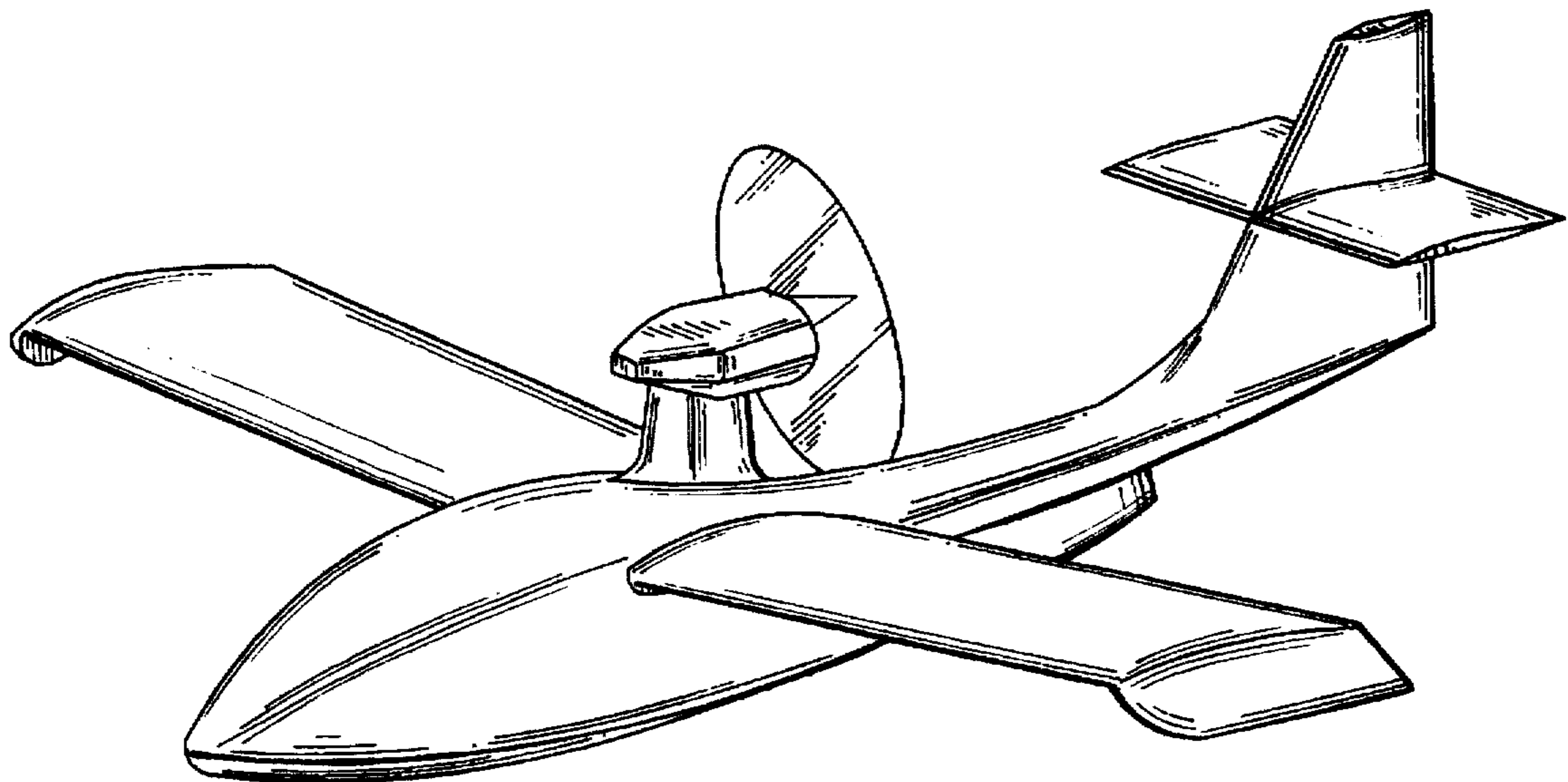

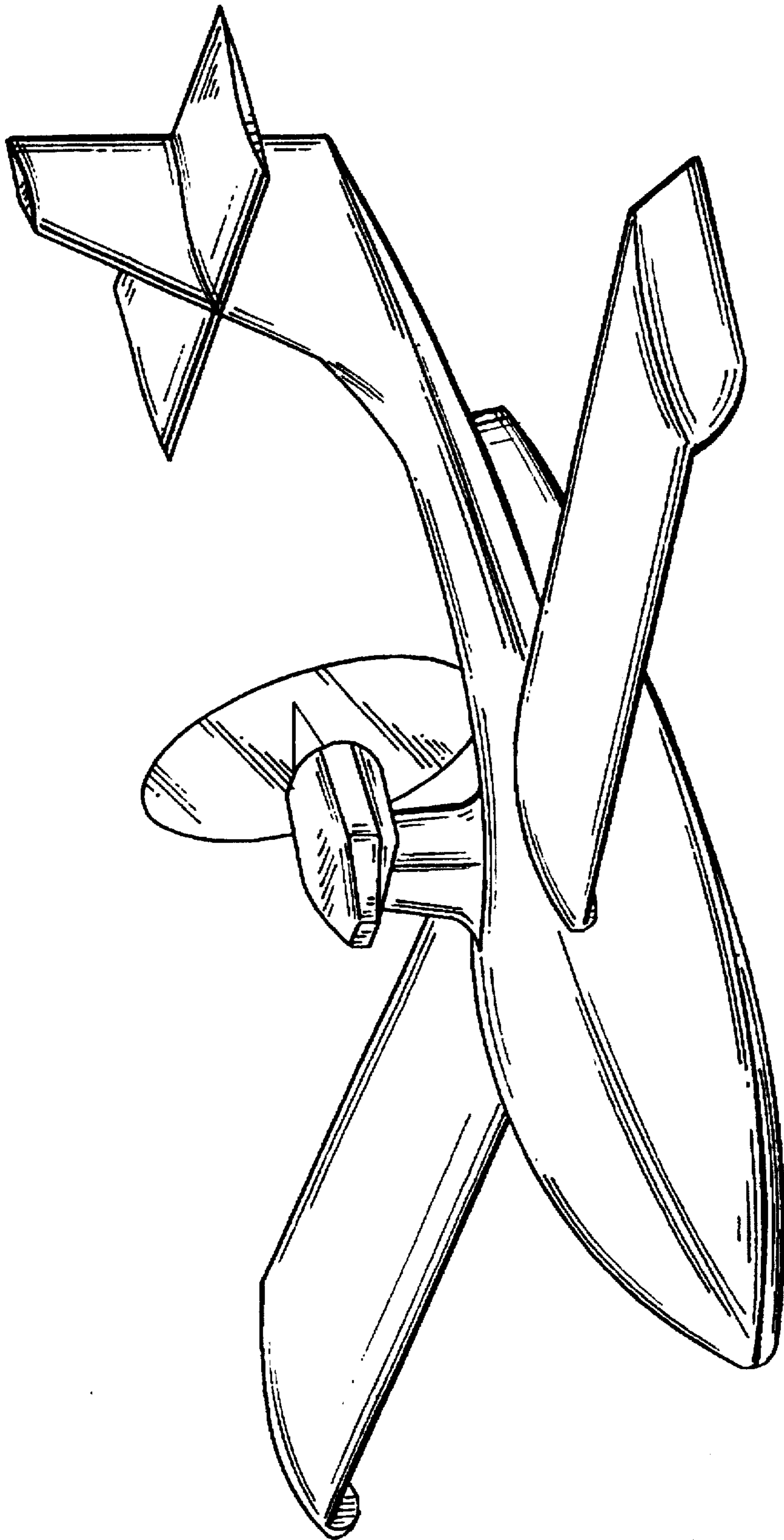

FIG. 1

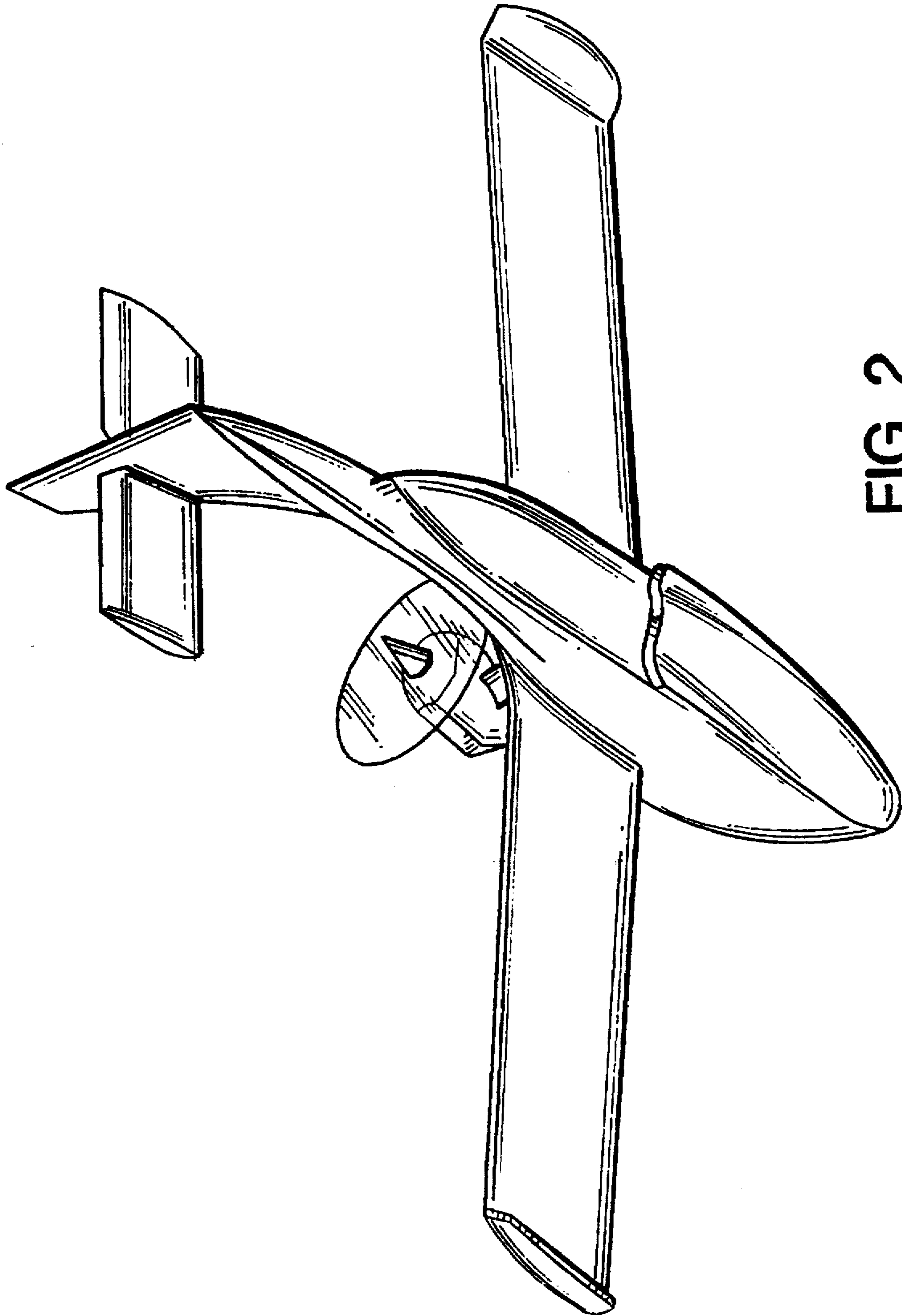

FIG. 2

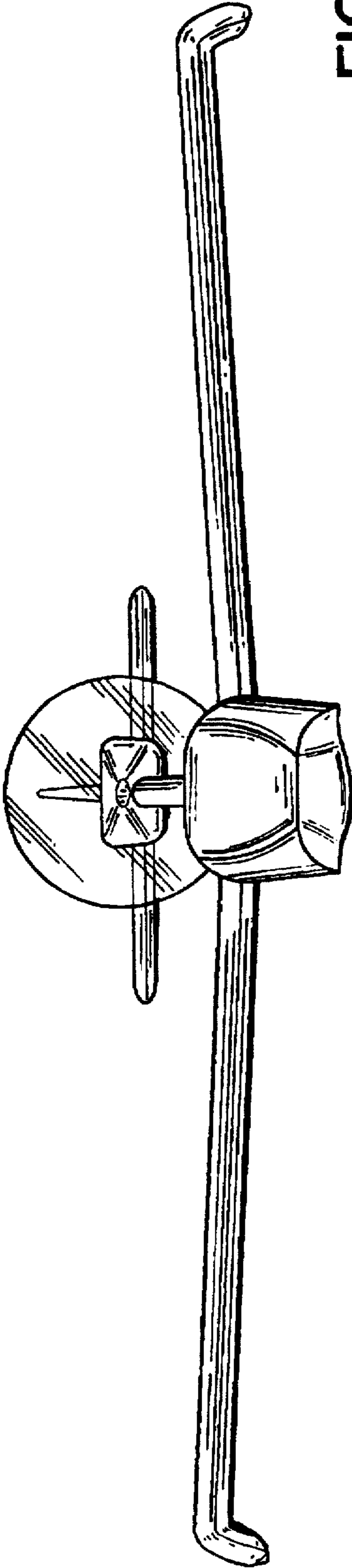

FIG. 3

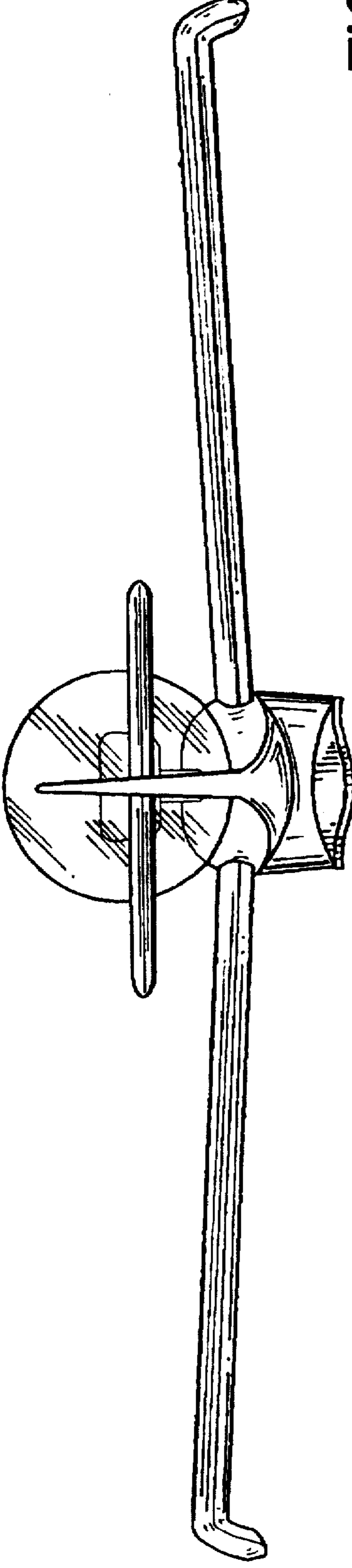

FIG. 5

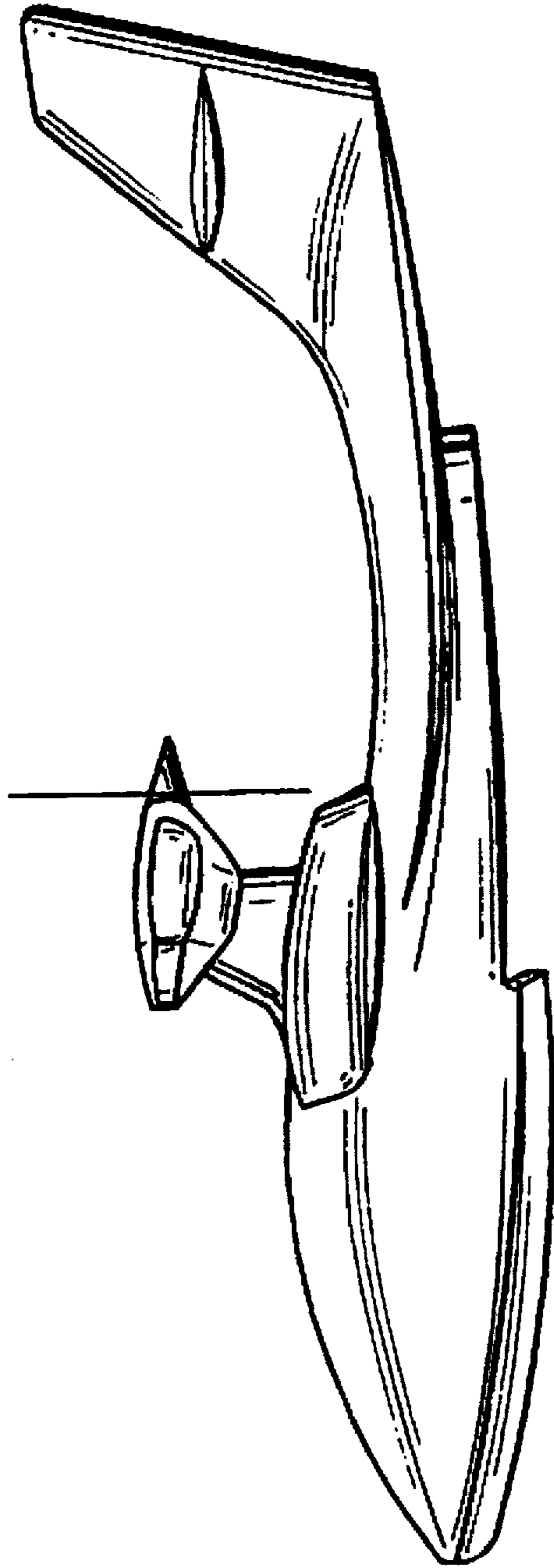

FIG. 4

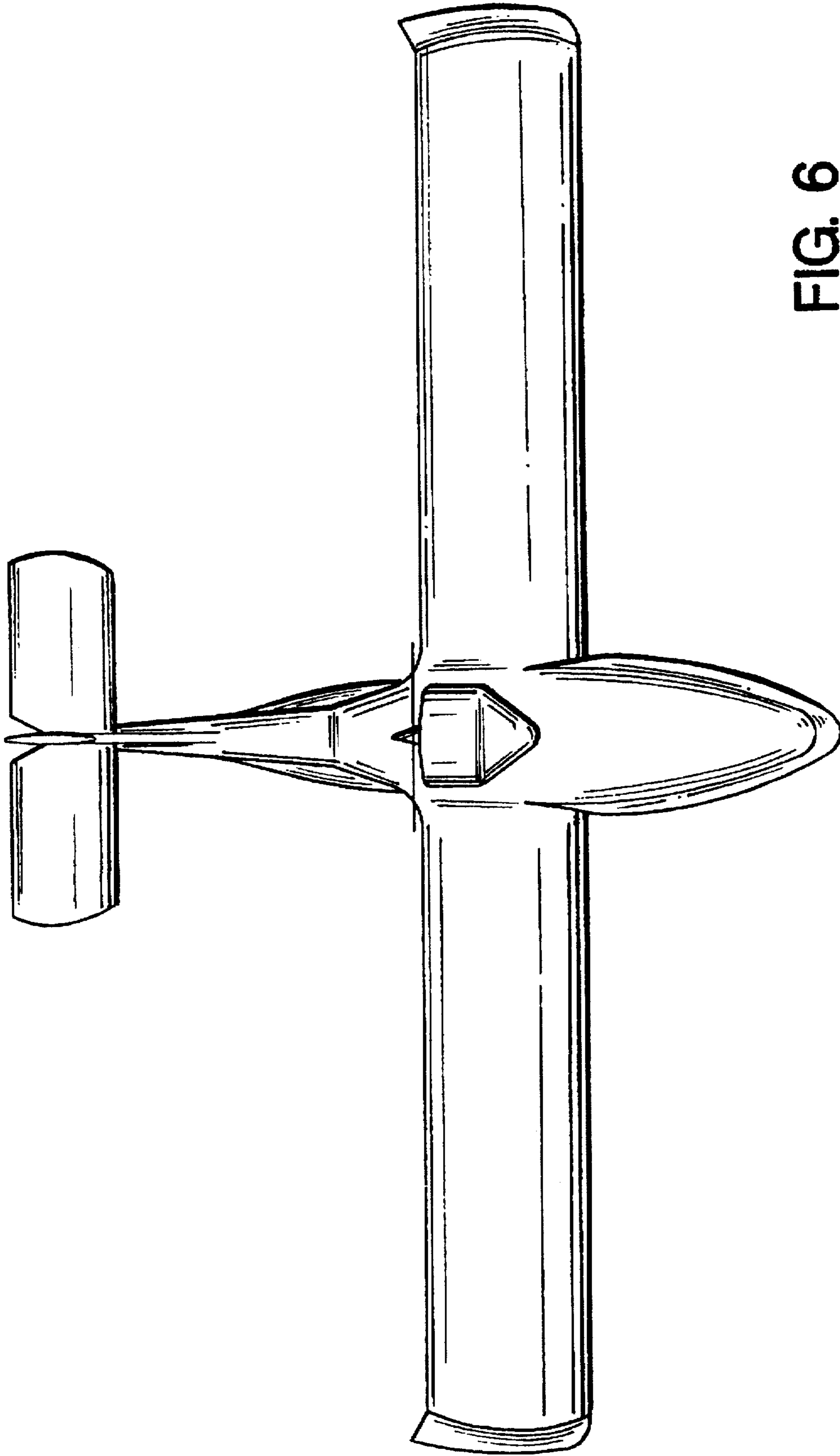

FIG. 6

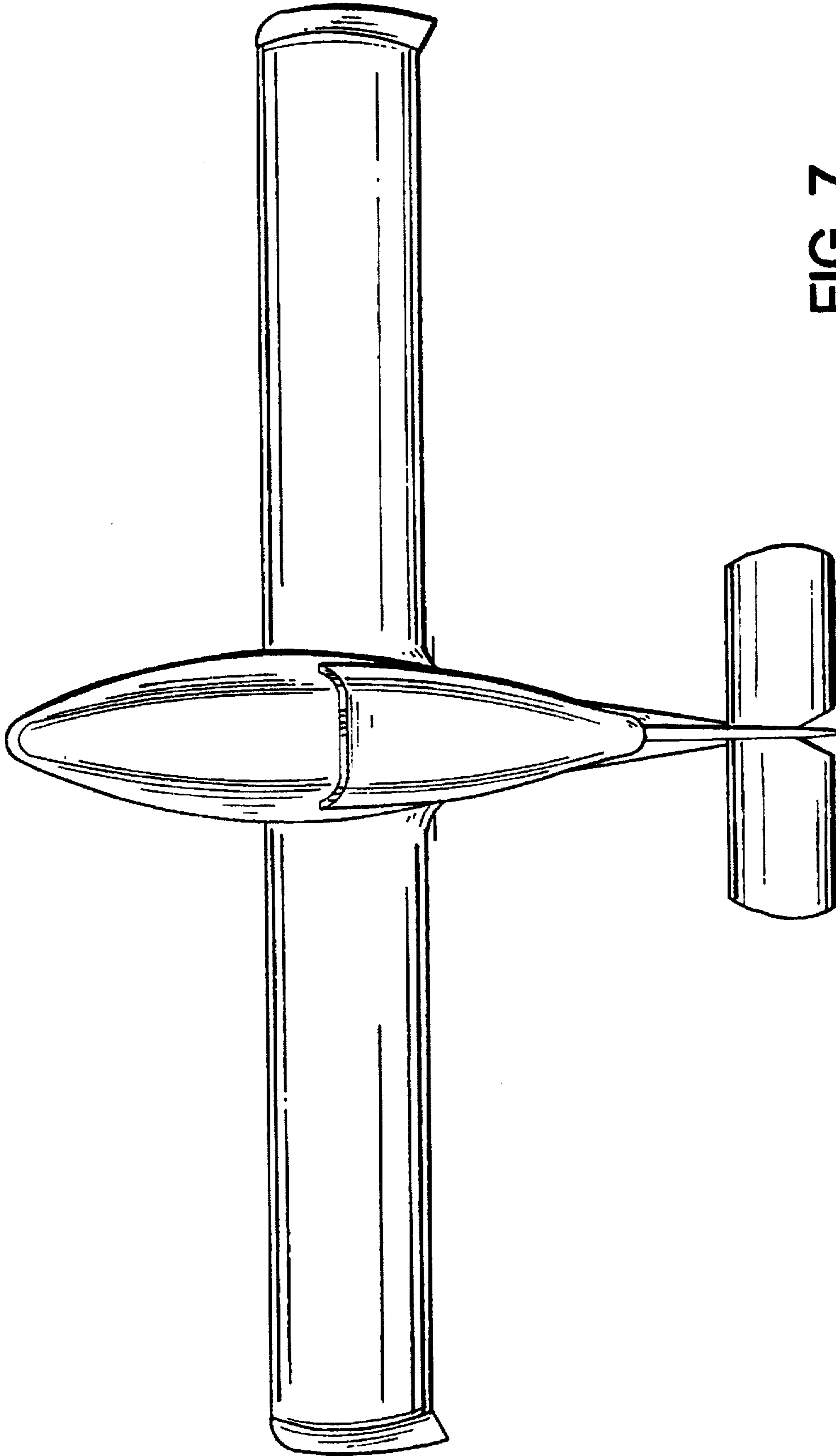

FIG. 7