



US00D392655S

**United States Patent** [19]  
**Mizukami**

[11] **Patent Number:** **Des. 392,655**  
[45] **Date of Patent:** **\*\*Mar. 24, 1998**

[54] **SET OF WIRE RINGS FOR A CLUTCH  
ESPECIALLY FOR AUTOMOTIVE RACING  
APPLICATIONS**

[75] **Inventor:** **Hiroshi Mizukami, Nayagawa, Japan**

[73] **Assignee:** **Exedy Corporation, Osaka, Japan**

[\*\*] **Term:** **14 Years**

[21] **Appl. No.:** **66,617**

[22] **Filed:** **Feb. 13, 1997**

**Related U.S. Application Data**

[63] **Continuation of Ser. No. 438,726, May 10, 1995, Pat. No. 5,638,932.**

**Foreign Application Priority Data**

May 17, 1994	[JP]	Japan	6-102499
May 17, 1994	[JP]	Japan	6-102501
Jul. 11, 1994	[JP]	Japan	6-158922

[51] **LOC (6) Cl.** ..... **15-99**

[52] **U.S. Cl.** ..... **D15/148**

[58] **Field of Search** ..... **D15/148, 149;**  
**192/70.14, 70.12, 107 R, 113 LC, 113 BG;**  
**188/264 D, 264 E**

[56] **References Cited**

**U.S. PATENT DOCUMENTS**

D. 237,900	12/1975	Stroup	D15/149
D. 288,694	3/1987	Dobbertin	D15/148
D. 288,934	3/1987	Brown	D15/148
D. 302,822	8/1989	Huber	D15/148
D. 302,823	8/1989	Huber	D15/148
D. 327,281	6/1992	Macomber	D15/149
D. 373,368	9/1996	Matsui et al.	D15/148
D. 373,369	9/1996	Matsui et al.	D15/148
4,667,793	5/1987	Kunz et al.	192/70.12
4,830,160	5/1989	Marshall	192/70.12
4,846,326	7/1989	Tilton et al.	192/70.19
5,099,973	3/1992	Flotow et al.	192/70.12
5,181,594	1/1993	Nash	192/70.27
5,226,516	7/1993	Novikoff et al.	192/70.28
5,301,779	4/1994	Nash	192/70.2
5,460,255	10/1995	Quigley	192/113.36

**FOREIGN PATENT DOCUMENTS**

1204539	9/1970	United Kingdom .
1352989	5/1974	United Kingdom .
1506738	4/1978	United Kingdom .
2165321	4/1986	United Kingdom .

*Primary Examiner*—Antoine Duval Davis  
*Attorney, Agent, or Firm*—Roylance, Abrams, Berdo & Goodman, L.L.P.

[57] **CLAIM**

The ornamental design for a set of wire rings for a clutch especially for automotive racing applications, as shown and described.

**DESCRIPTION**

FIG. 1 is a side elevational view illustrating a set of wire rings for a clutch, especially for automotive racing applications in accordance with my new design;

FIG. 2 is a longitudinal cross-sectional view of the set of wire rings for a clutch, especially for automotive racing applications as illustrated in FIG. 1, taken along section lines 2—2 of FIGS. 4 and 6;

FIG. 3 is a partial perspective view of the set of wire rings for a clutch especially for automotive racing applications as illustrated in FIGS. 1 and 2 as viewed along section line 3—3 of FIG. 1;

FIG. 4 is a left end elevational view of the left wire ring of the set of wire rings for a clutch, especially for automotive racing applications as illustrated in FIGS. 1 and 2 as viewed along section line 4—4 of FIG. 1;

FIG. 5 is a right end elevational view of the left wire ring of the set of wire rings illustrated in FIGS. 1 and 2 as viewed along section line 5—5 of FIG. 1;

FIG. 6 is a left end elevational view of the right wire ring of the set of wire rings for a clutch, especially for automotive racing applications as illustrated in FIGS. 1 and 2 as viewed along section line 6—6 of FIG. 1; and,

FIG. 7 is a right end elevational view of the right wire ring of the set of wire rings for a clutch, especially for automotive racing applications as illustrated in FIGS. 1—3 as viewed along section line 7—7 of FIG. 1.

**1 Claim, 3 Drawing Sheets**

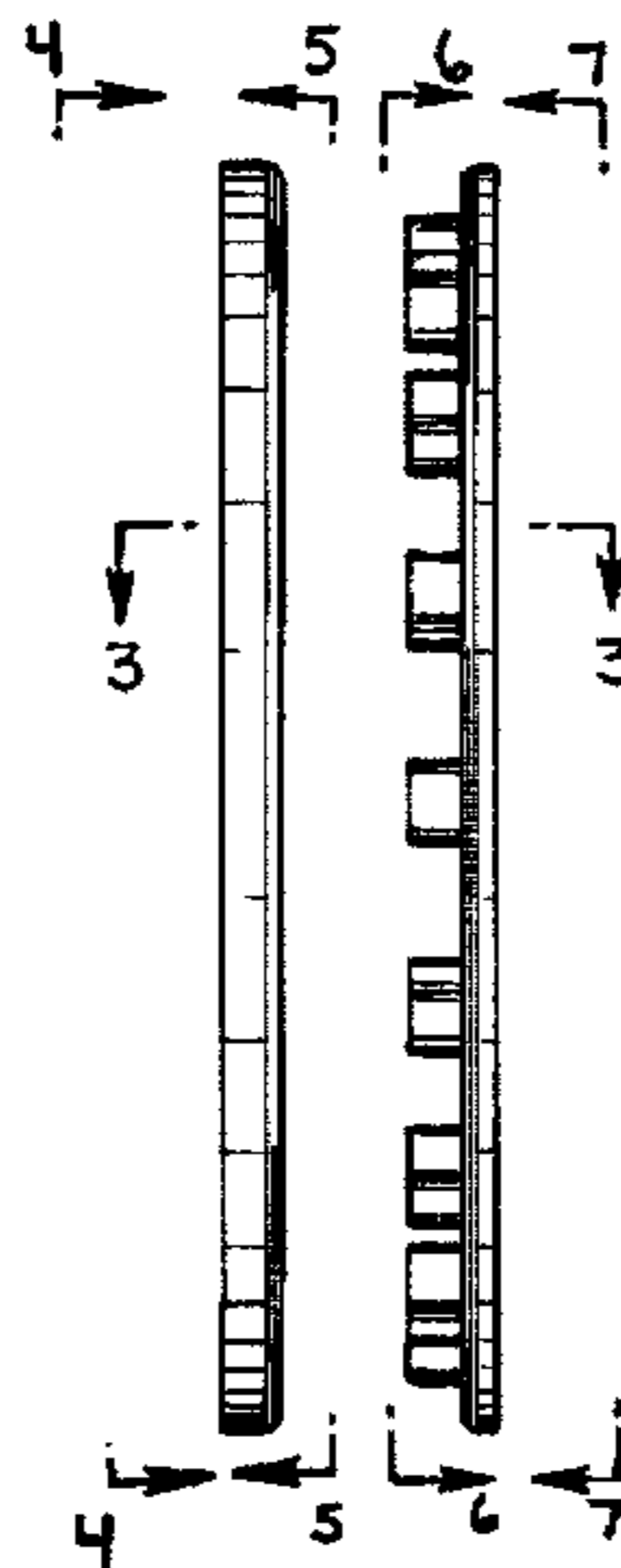

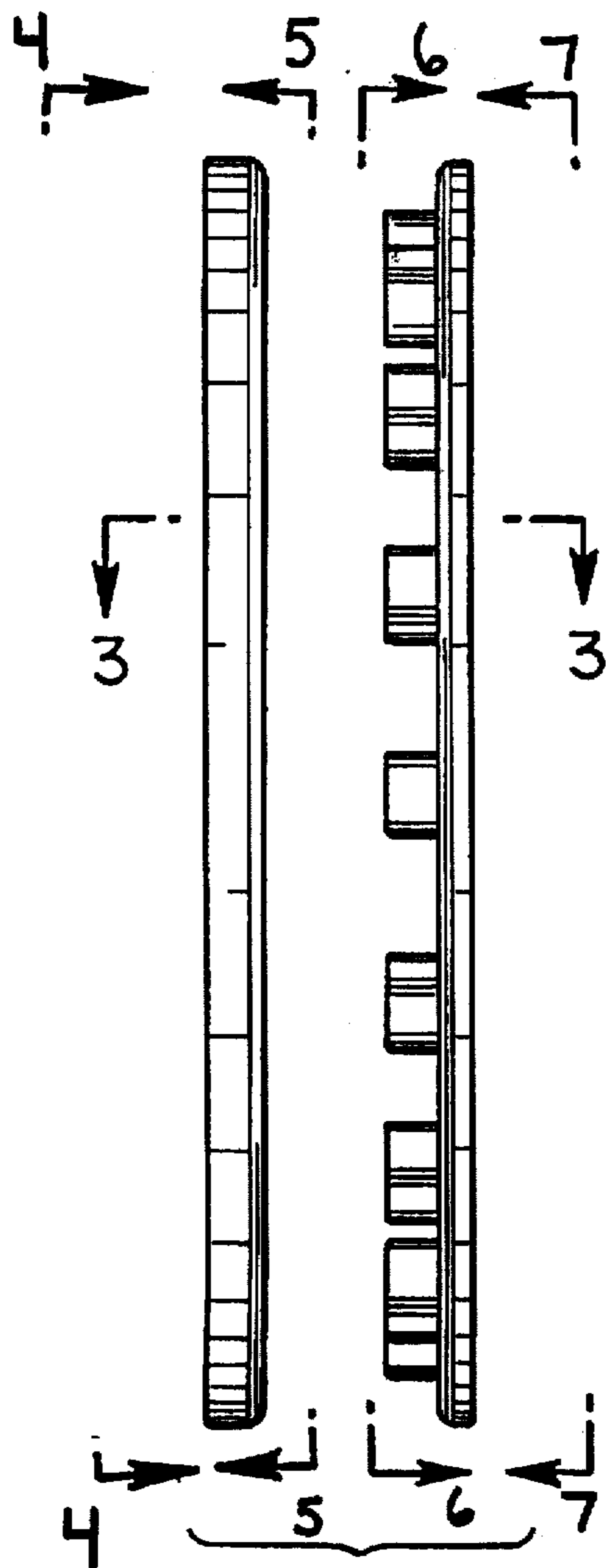

FIG. 1

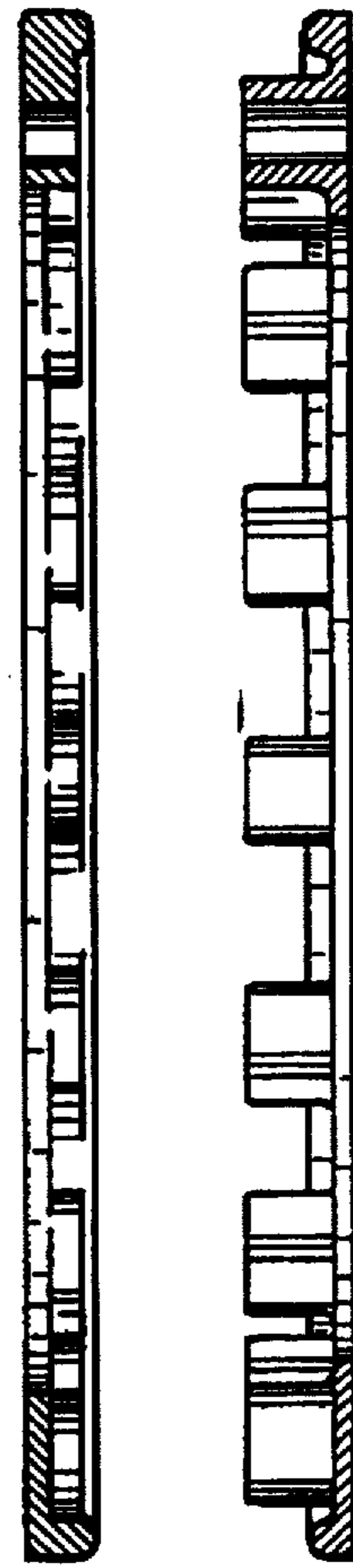

FIG. 2

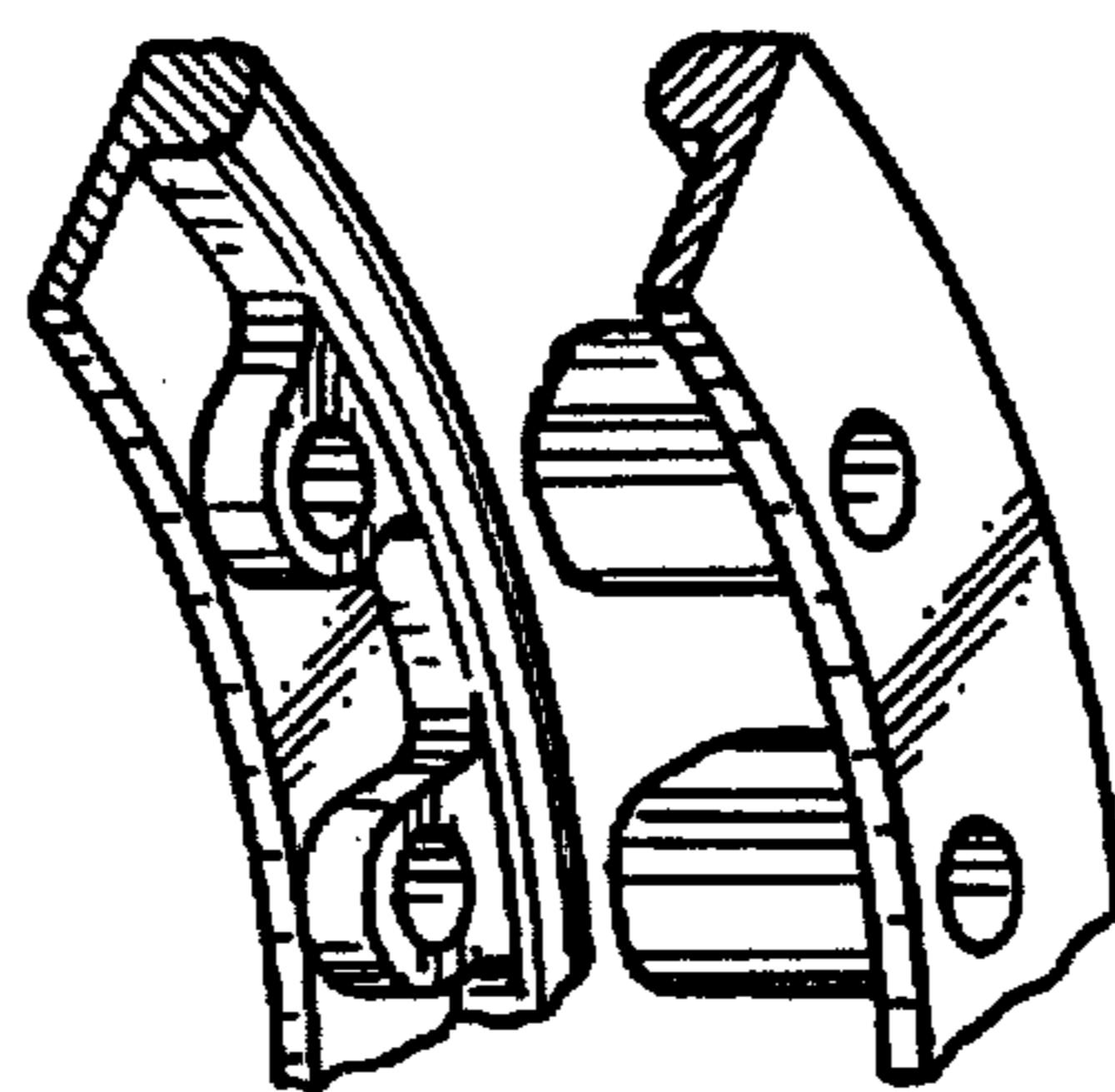

FIG. 3

