



US00D392336S

United States Patent [19]

[11] Patent Number: Des. 392,336

Liu

[45] Date of Patent: **Mar. 17, 1998

[54] VIDEO GAME

5,161,803 11/1992 Ohara 463/44
5,184,830 2/1993 Okada et al. 463/47 X

[76] Inventor: Da-Ming Liu, 5F., No. 13, Pao Kao Rd., Hsin Tien, Taipei Hsien, Taiwan

OTHER PUBLICATIONS

[**] Term: 14 Years

Hong Kong Enterprise, p. 245, Oct. 1994.

[21] Appl. No.: 70,629

Primary Examiner—Prabhakar G. Deshmukh
Attorney, Agent, or Firm—Jacobson, Price, Holman & Stern, PLLC

[22] Filed: May 12, 1997

[51] LOC (6) Cl. 21-01

[52] U.S. Cl. D21/13

[58] Field of Search D21/1, 13, 48;
273/148 B; 463/30-35, 43-47, 1; D14/125,
126, 114

[57] CLAIM

The ornamental design for video game, as shown and described.

DESCRIPTION

FIG. 1 is a perspective view of video game showing my new design;
FIG. 2 is a front elevational view thereof;
FIG. 3 is a rear elevational view thereof;
FIG. 4 is a left side elevational view thereof;
FIG. 5 is a right side elevational view thereof;
FIG. 6 is a top plan view thereof; and,
FIG. 7 is a bottom plan view thereof.

[56] References Cited

U.S. PATENT DOCUMENTS

D. 270,075	8/1983	Tsuyuki	D21/13
D. 309,161	7/1990	Leung	D21/13
D. 336,315	6/1993	Kitaue	D21/13
D. 347,246	5/1994	Wen	D21/13
D. 367,295	2/1996	Hsieh	D21/13 X
D. 369,190	4/1996	Feiz	D21/13

1 Claim, 3 Drawing Sheets

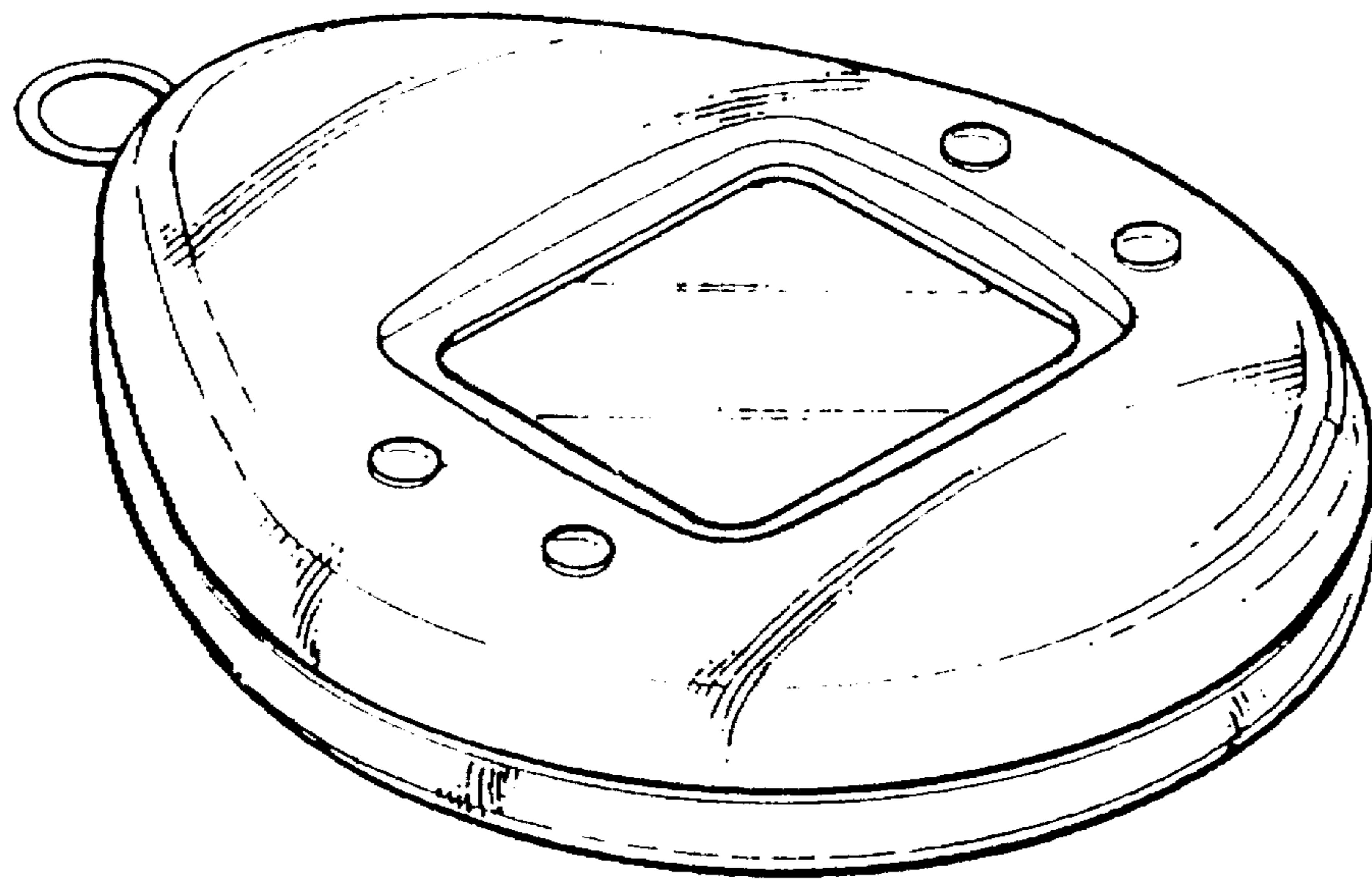

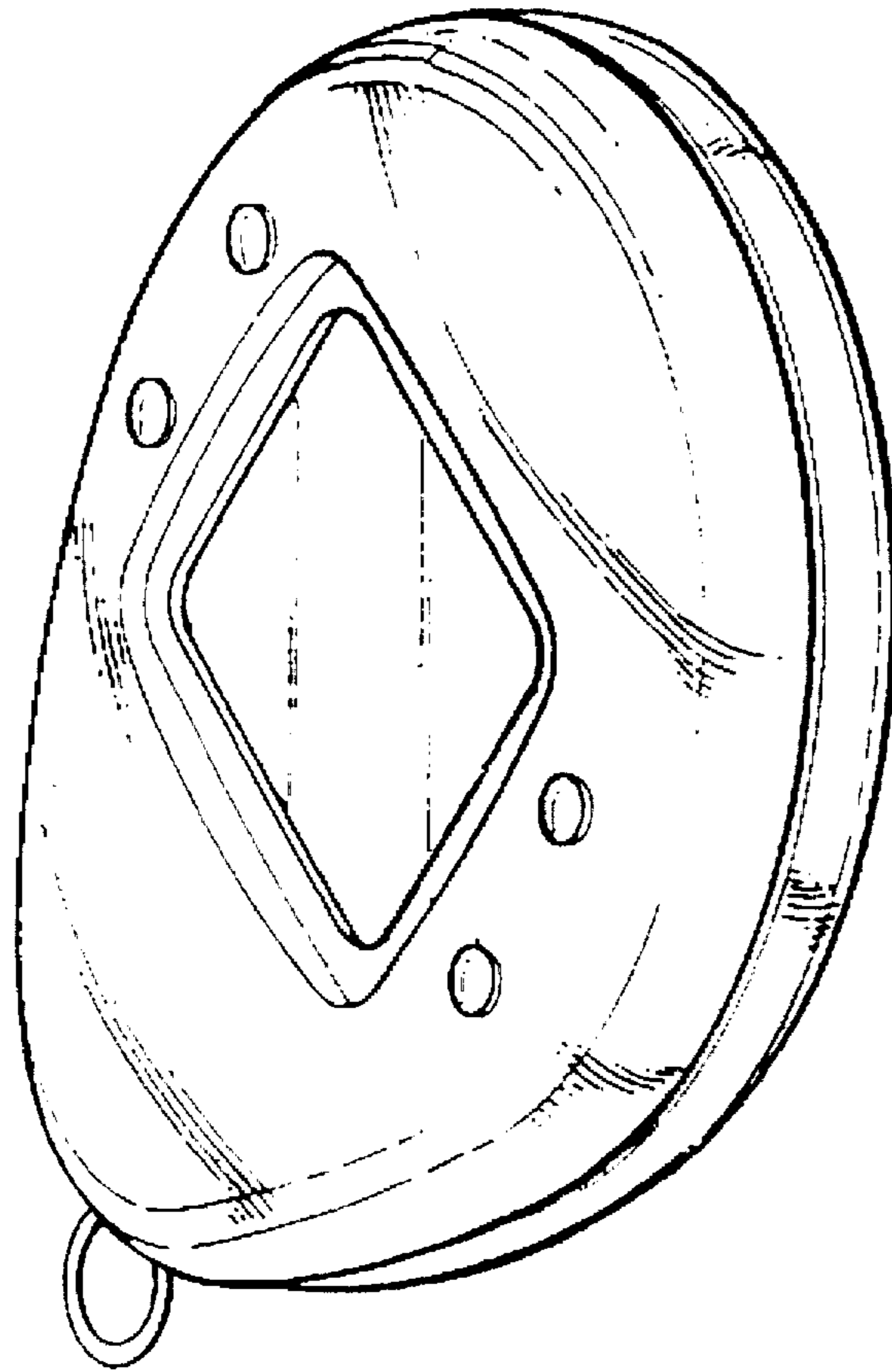

FIG 1

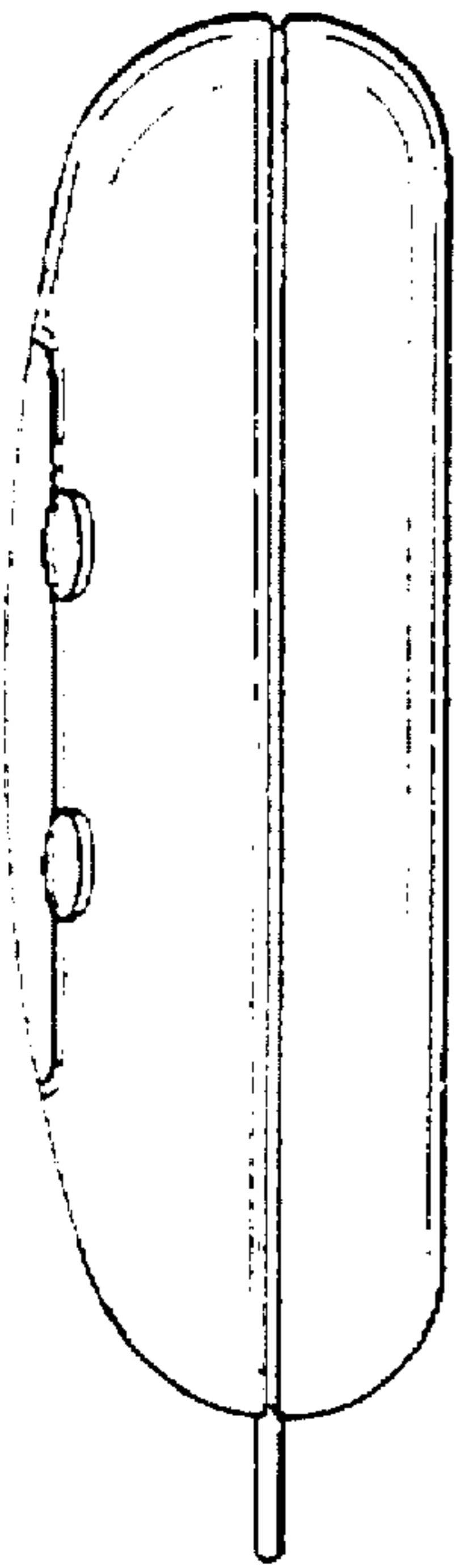

FIG 2

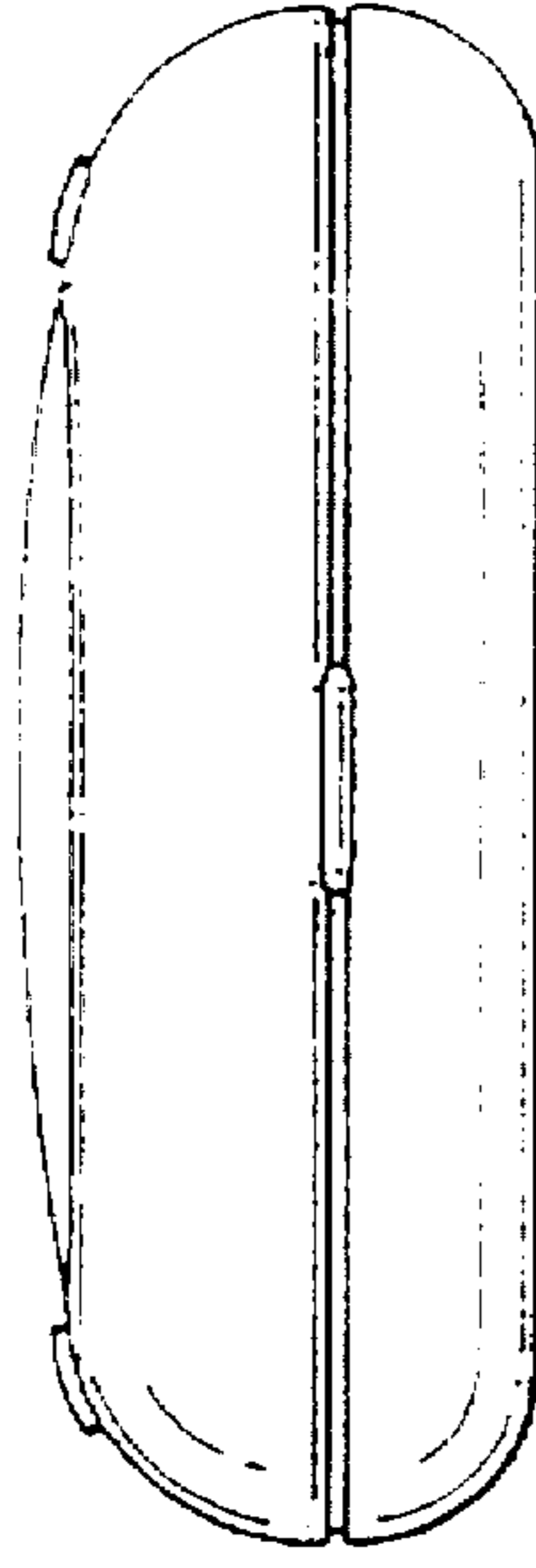

FIG 4

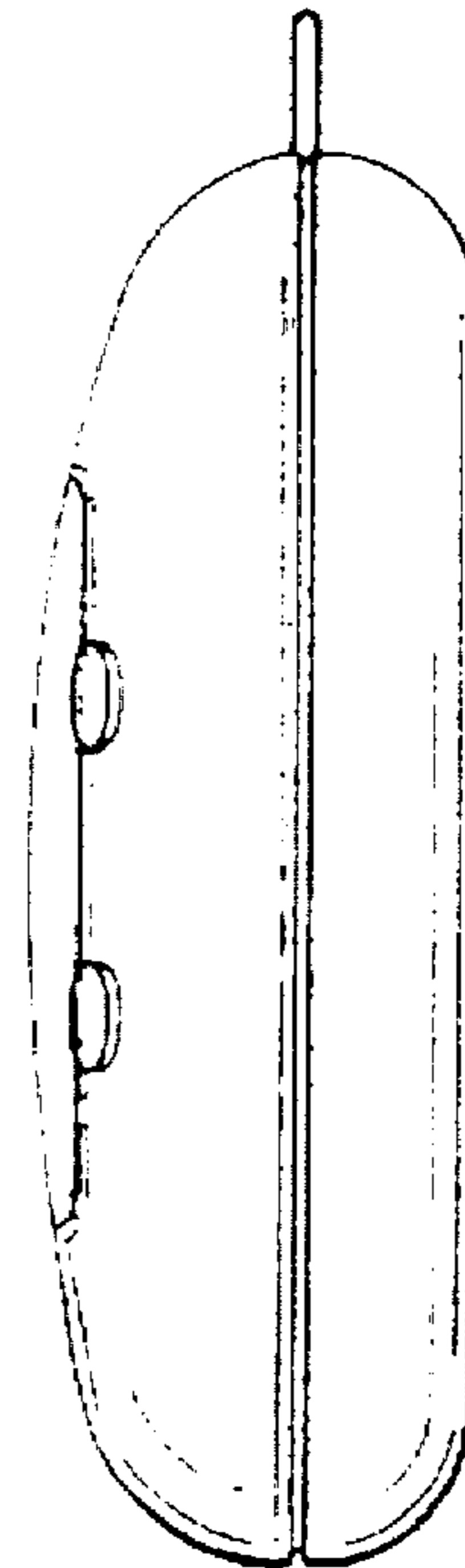

FIG 3

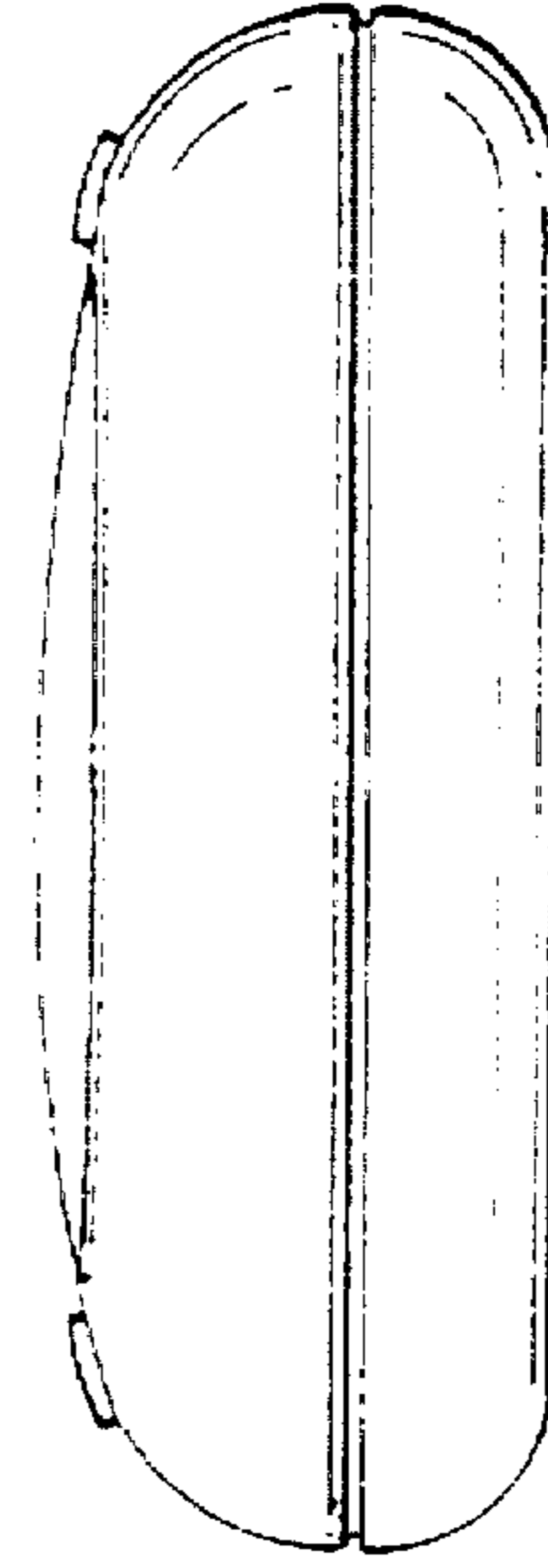

FIG 5

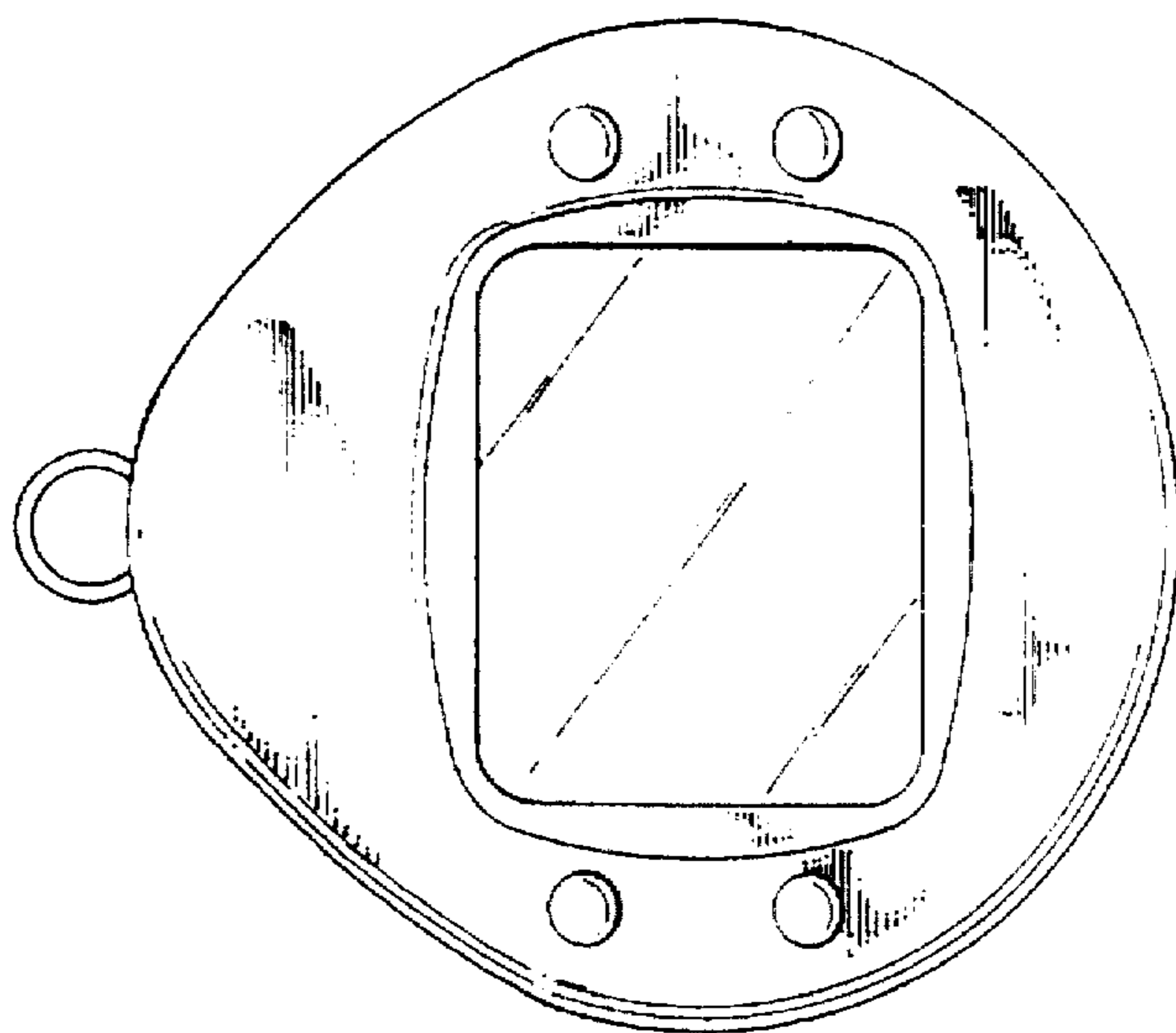

FIG 6

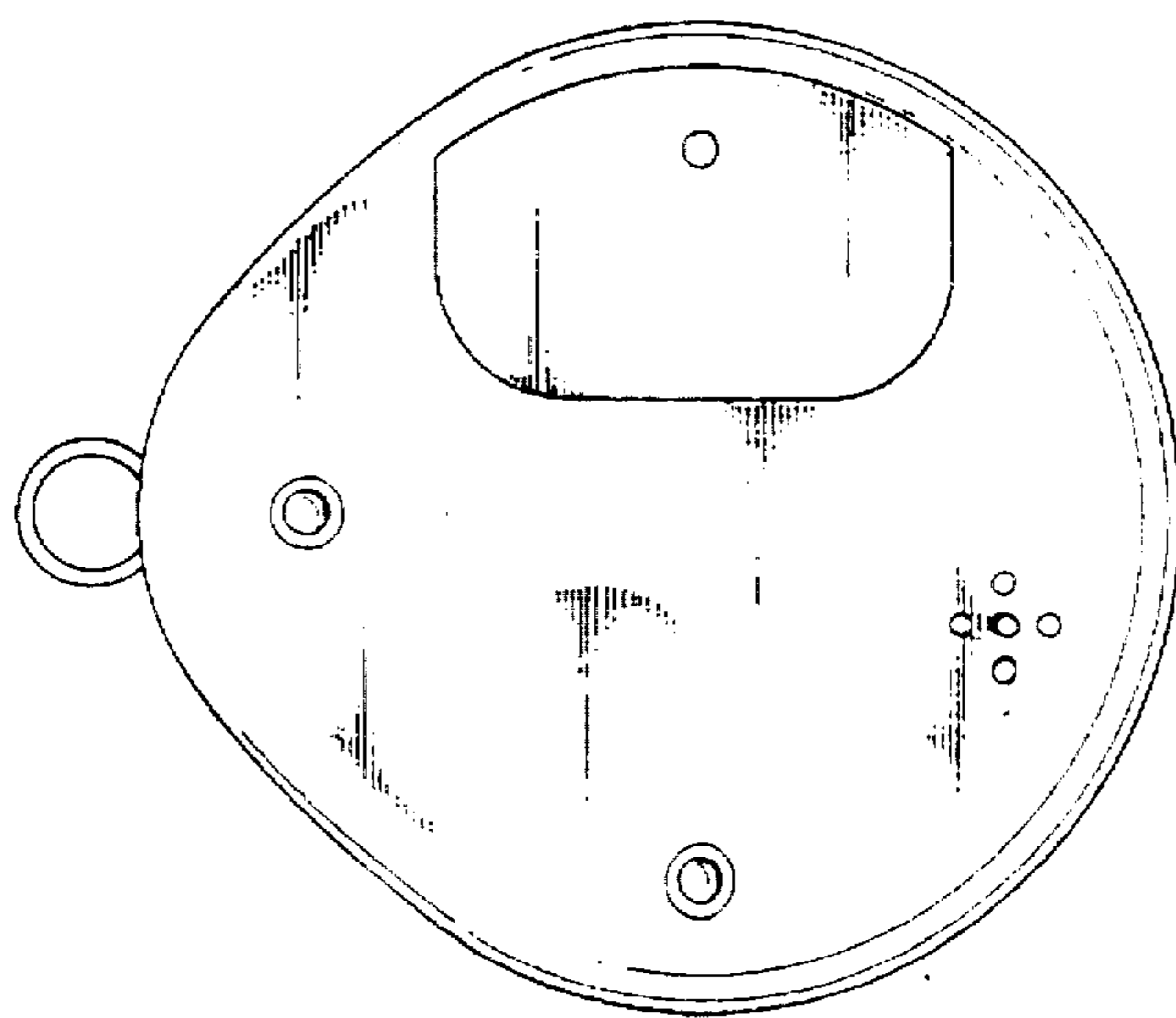

FIG 7