



US00D392232S

United States Patent [19]

[11] Patent Number: Des. 392,232

Lucht et al.

[45] Date of Patent: **Mar. 17, 1998

[54] MOTORCYCLE BUMPER

OTHER PUBLICATIONS

[75] Inventors: Doreen Lucht, Franklin; William G. Davidson, Delafield, both of Wis.

1949 Hydra Glide. The Harley-Davidson Motor Company, 1987, p. 82.

[73] Assignee: Harley-Davidson Motor Company, Milwaukee, Wis.

Harley Davidson Genuine Parts & Accessories pp. 74 & 77 the Electra Glo rear bumper & Electra Glide front bumper. ©1995.

[**] Term: 14 Years

Primary Examiner—Melody N. Brown

Attorney, Agent, or Firm—Michael, Best & Friedrich LLP

[21] Appl. No.: 57,544

[57] CLAIM

[22] Filed: Jul. 26, 1996

The ornamental design for a motorcycle bumper, as shown and described.

[51] LOC (6) Cl. 12-16

[52] U.S. Cl. D12/169; D12/114

[58] Field of Search D12/167, 169, D12/171, 186, 114; 293/102, 115, 142, 143

DESCRIPTION

FIG. 1 is a perspective view of a motorcycle bumper showing our new design, the broken lines are for illustrative purposes only and form no part of the claimed design; FIG. 2 is a top plan view thereof, the bottom view being a mirror image of the top view shown; FIG. 3 is a rear elevational view thereof; and, FIG. 4 is a side elevational view thereof, the opposite side being a mirror image of that side shown. The front view of the motorcycle bumper is flat and unornamented.

[56] References Cited

U.S. PATENT DOCUMENTS

D. 234,501	3/1975	Hanagan	D12/186
D. 234,502	3/1975	Hanagan	D12/186
D. 310,197	8/1990	McNamara	D12/167

1 Claim, 2 Drawing Sheets

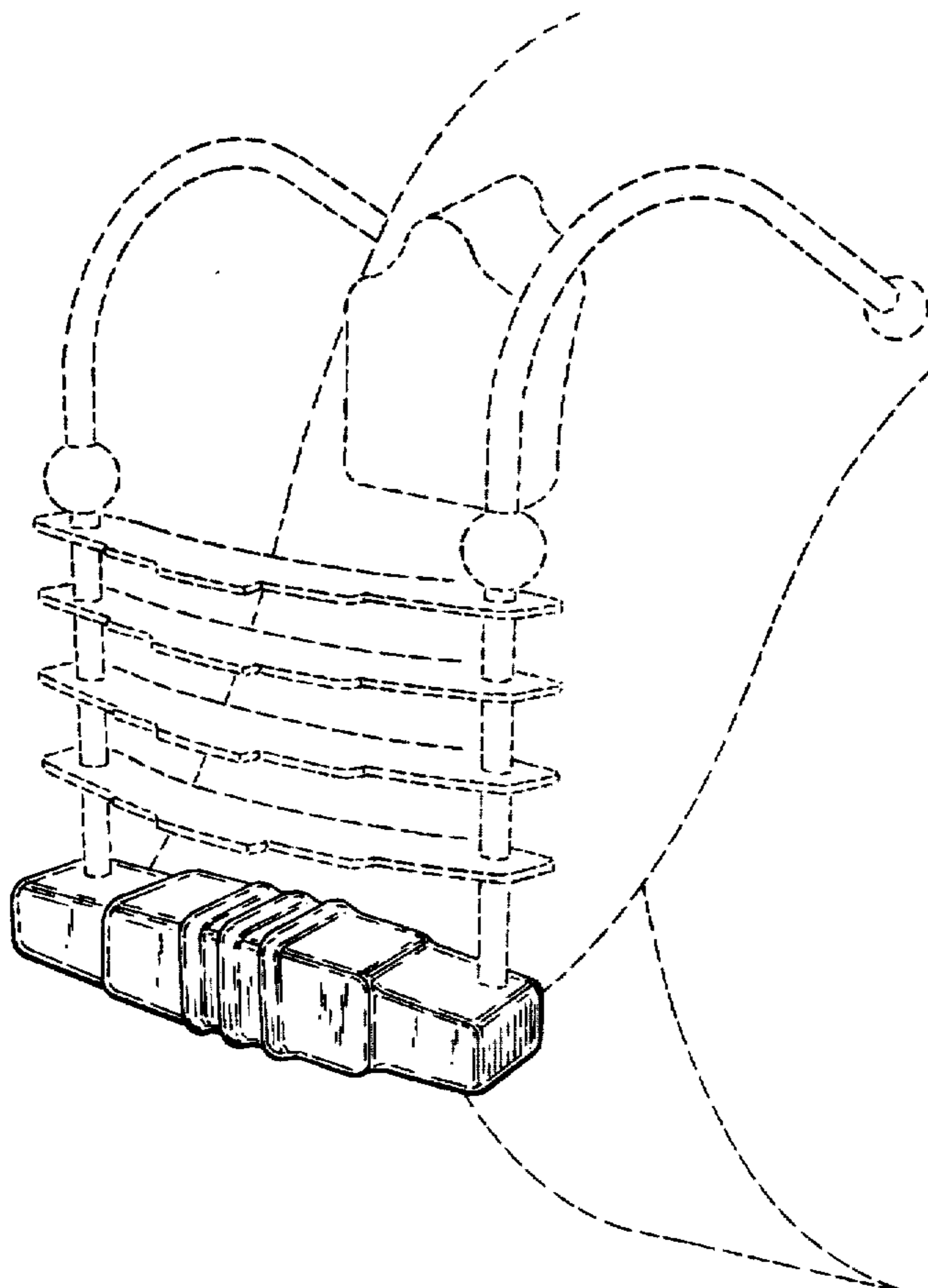

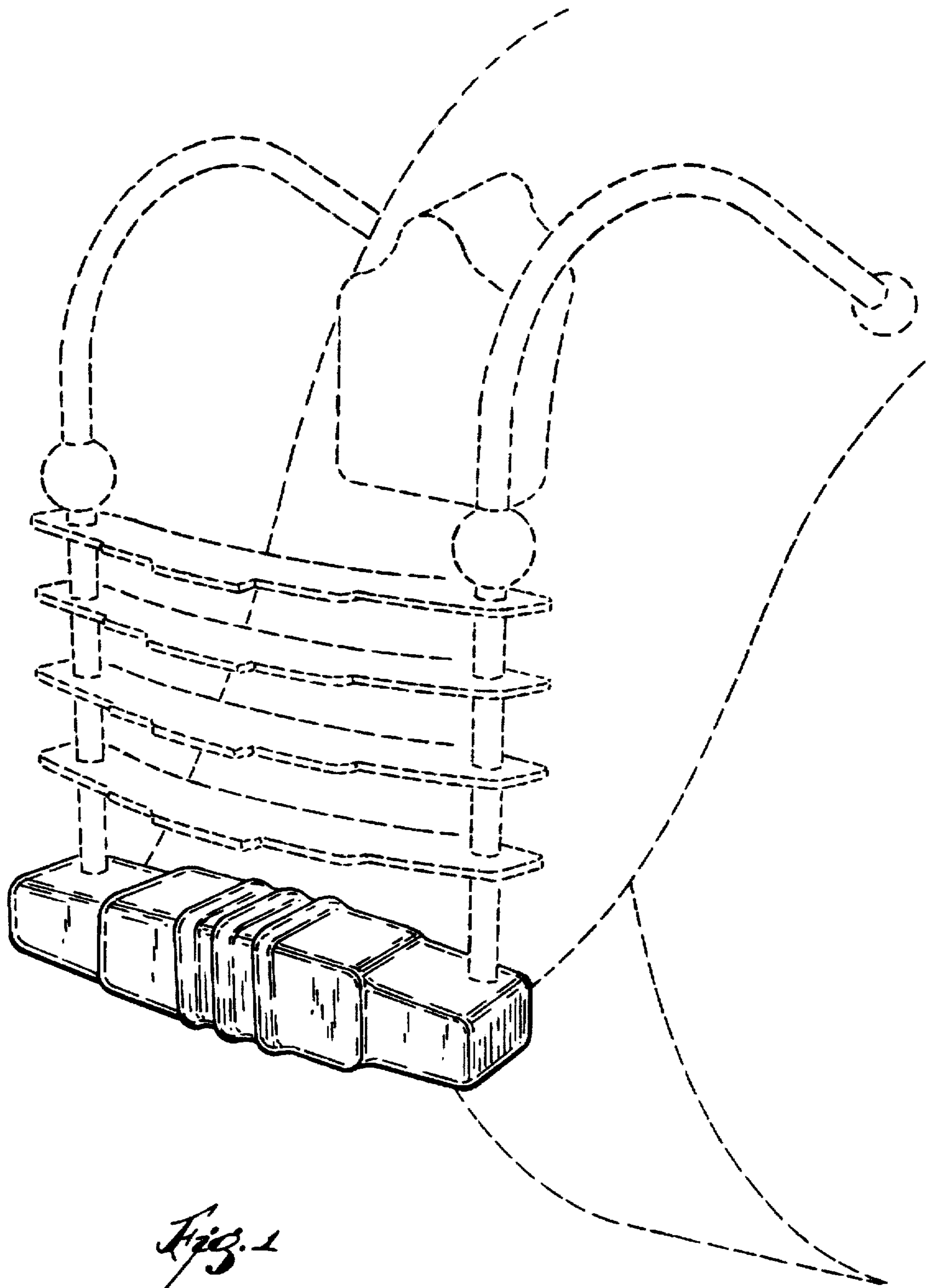

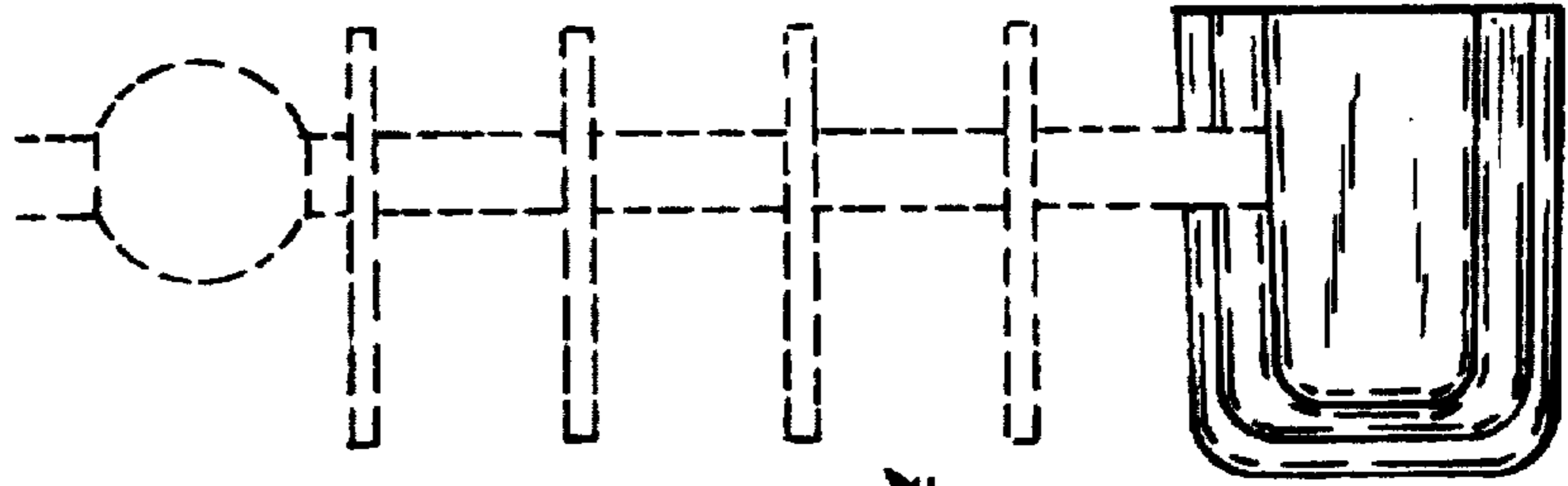

Fig. 4

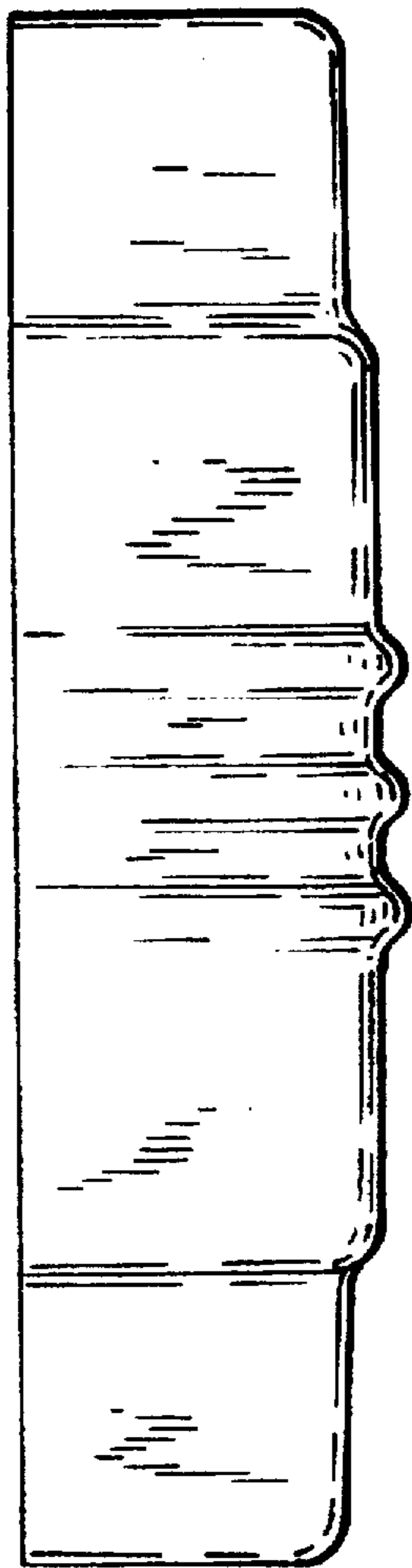

Fig. 2

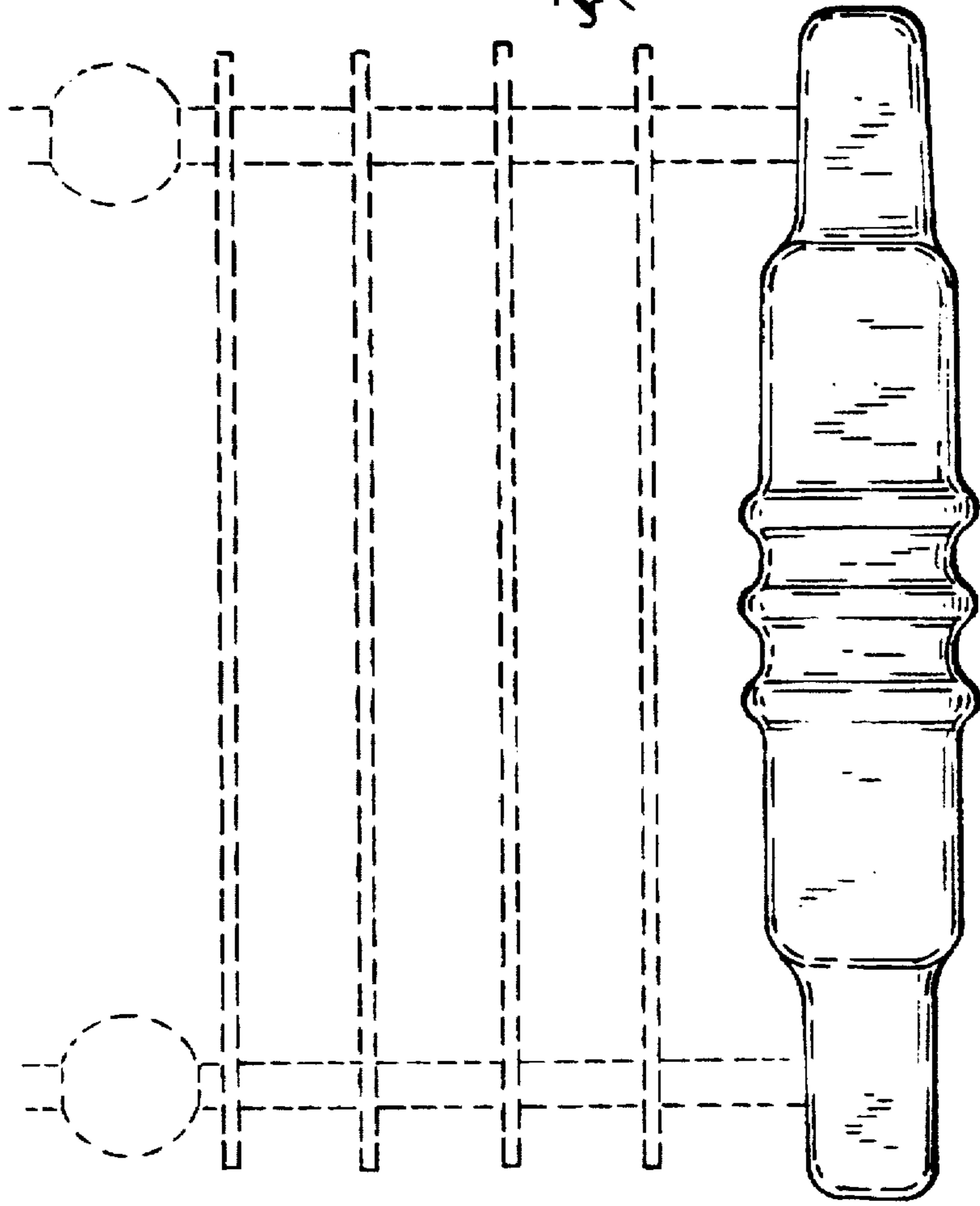

Fig. 3